

Jun.2017 / Vol.158

M i t s u b i s h i E l e c t r i c

ADVANCE

FA Products Latest Trend in e-F@ctory System

• **Editorial-Chief**

Tomoyuki Kobayashi

• **Editorial Advisors**

*Toshio Masujima
Naoshi Sakai
Hiroshi Takenaka
Hiroaki Sakai
Akihide Shiratsuki
Chikao Nishida
Hitoshi Suzuki
Kunihiko Egawa
Shinichi Kuroda
Masanori Torii
Hiroaki Imamura
Hideyuki Takasago
Noboru Shirakura
Takayuki Hayashi
Toshihiro Kurita*

• **Vol. 158 Feature Articles Editor**

Koichi Togawa

• **Editorial Inquiries**

*Tomoyuki Kobayashi
Corporate Total Productivity Management
& Environmental Programs
Fax: +81-3-3218-2465*

• **Product Inquiries**

*Norimichi Yahagi
Planning & Administration Section
Overseas Planning & Administration
Department
Fax: +81-3-3218-6820*

Mitsubishi Electric Advance is published on line quarterly (in March, June, September, and December) by Mitsubishi Electric Corporation. Copyright © 2017 by Mitsubishi Electric Corporation; all rights reserved. Printed in Japan.

The company names and product names described herein are the trademarks or registered trademarks of the respective companies.

CONTENTS

Technical Reports

Overview1
by *Joachim Seidelmann*

MELSEC IQ-R Series Safety PLC2
by *Masahiro Uchikoshi*

Development of MELSOFT GX Works36
by *Koji Aoyama and Shogo Morita*

New Function of Graphic Operation Terminal "GOT2000 Series"9
by *Kei Gomita and Tomoko Yamada*

CC-Link IE Field Compatible Servo System12
by *Hiroto Takei and Yoshiaki Irifune*

Industrial Robots "MELFA FR Series"15
by *Yoshitaka Kumagai*

Expansion of Circuit Breaker Lineup for High-Voltage Direct Current19
by *Nobuo Miyoshi*

Precis

Since 2003, Mitsubishi Electric Corporation has engaged in the integrated FA solution initiative named e-F@ctory, which has evolved around the key concept of reducing overall cost at the development, manufacturing, and maintenance stages. Under the e-F@ctory solution scheme, we have been optimizing customers' factories by adopting advanced technologies and making full use of information, enabling us to maintain a leading position over our competitors in the manufacturing industry.

This issue presents the latest FA equipment products that reinforce the e-F@ctory integrated FA solution.

Overview



Author: *Joachim Seidelmann**

The Digital Factory Based on Cyber-physical Systems

One of the major challenges for manufacturing in-dustry in the well-developed countries like North America, Europe, and Japan for the next decade will be the transformation from mass production into a production environment which enables manufacturing of highly customized products at the cost the consumer is used from mass production (mass customization). The trend of individualization of products is even accelerated by the appearance of cyber-physical products (Internet of Things, IoT), where a major part of the individualization is done by customer itself via software. Additionally, the manufacturing industry is still driven by the need for more efficient production becoming more sustainable, with regard to energy, material, and work force (mass sustainability).

To tackle the challenges of mass customization and mass sustainability, it seems obvious to apply the concepts and technologies of cyber-physical solutions also to production systems to build cyber-physical production system (CPPS) the basis for the Digital Factory. Digital Factories, as well as Connected Digital Factories or digital value chains, need a high degree of IT-integration in basically three dimensions. The first dimension is the horizontal integration along the value chain, the second dimension is the vertical integration from Enterprise Resource Planning (ERP) level down to the sensor on the shop floor, and the third dimension is the consistent integration of the digital engineering from design, via the manufacturing, the operation and the recycling phases of the life cycle of (cyber-physical) products.

To enable the high degree of IT-integration and communication new types of IT-architectures has to be deployed to the manufacturing industry. The usage of service-oriented architectures (SOA) on all levels of the ISA 95 pyramid for enterprise control systems integration (ERP level, MES level, and PLC/sensor/actor level) will enable data and service integration overcoming conventional architectures implementing multiple data silos in manufacturing networks. Additionally, applications will be split into more granular services and provisioned out of IT-cloud infrastructures enable the implementation and operation of highly flexible manufacturing IT solution at lower cost. This IT-architecture concept, also used in open source robotics control (industrial ROS) and IoT-platforms, also driven by major players from the IT industry like Google, Intel, and Microsoft with the goal of directly getting access to the data of the end customers shop floor, will enable the data-and knowledge-driven manufacturing needed for mass customized production.

Several national and global initiatives have been started by the industry and the national governments to support the digitalization of the manufacturing industry. Two major tasks have to be fulfilled by these initiatives. The first task is to work on a common understanding of the scope of Digital Factory on a global level. A good way to do so is to develop reference architectures as a basis for the discussion of different concepts and solutions. Based on these discussions standards can be easier developed and implemented into the industry. Second task is to mobilize small and medium sized enterprises (SMEs) as the benefits of the digitalization can only be leveraged in total when all involved parties in manufacturing industry support it.

MELSEC iQ-R Series Safety PLC

Author: Masahiro Uchikoshi*

A safety PLC means a PLC that is equipped with safety functions and is certified according to the international safety standards of ISO 13849-1 (PL = e, Category 4) and IEC 61508 (SIL 3).

Mitsubishi Electric's PLC line already includes the QS Safety PLC series. As this PLC series is designed exclusively for safety control purposes, it is necessary to set the system separately from those for non-safety control. This makes it difficult to reduce the space, wiring, and cost of FA systems as requested by our customers. Against this backdrop, we commenced the development of new safety PLCs and completed the MELSEC iQ-R series with the concept of integrating safety control and non-safety control.

1. Product Features

The following describes the three main features of the MELSEC iQ-R series safety PLCs.

1.1 Safety and non-safety modules sharing the same base module

The MELSEC iQ-R series safety CPUs can execute both safety control programs and non-safety control programs. This allows users to integrate safety control and non-safety control on the same CPU.

In addition, MELSEC iQ-R series safety PLCs allow non-safety modules (CPU, I/O, analog, and positioning/counting modules), safety modules (safety CPUs), and shared modules for safety control and non-safety control (power supply and network modules) to be mounted on the same base module. This allows users to configure the safety control and non-safety control in a single system, thus reducing the footprint, wiring and cost.

1.2 Network integration of safety control and non-safety control

When building a network in the conventional manner, the user constructs separate networks for the safety control (safety communications) and the non-safety control (non-safety communications). (See Fig. 1 [a].) This increases the network cables, wiring space, and cable installation man-hours.

With the MELSEC iQ-R series safety PLCs, the safety communications and non-safety communications can be used in the same CC-Link IE Field network (Fig. 1 [b]); the only thing that needs to be constructed is a CC-Link IE Field network. This reduces the wiring

space, number of cables, and cable installation man-hours for users, as well as the network's footprint, number of wires, and cost.

1.3 Integration of development environments

As engineering software, GX Works2 is generally used for the non-safety control, and GX Developer for the safety control.

With the MELSEC iQ-R Series safety PLCs, users can perform safety control programming, non-safety control programming, and various setting operations in an integrated manner using the GX Works3 engineering software (Fig. 2). Users only need to learn how to operate the software.

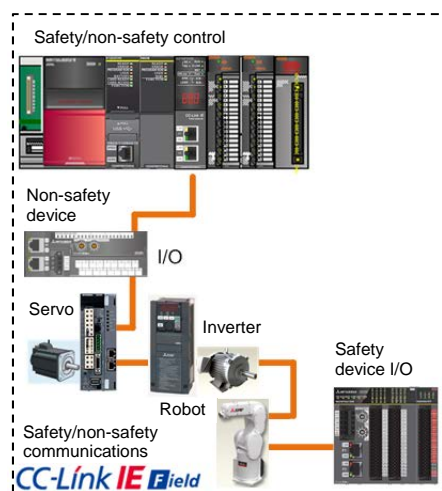
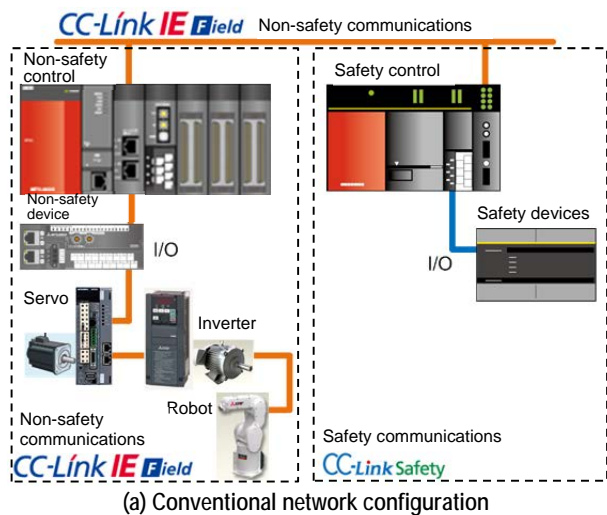

(b) Safety/non-safety communications integration using a CC-Link IE Field network

Fig. 1 Network integration of non-safety communications and safety communications

*Nagoya Works

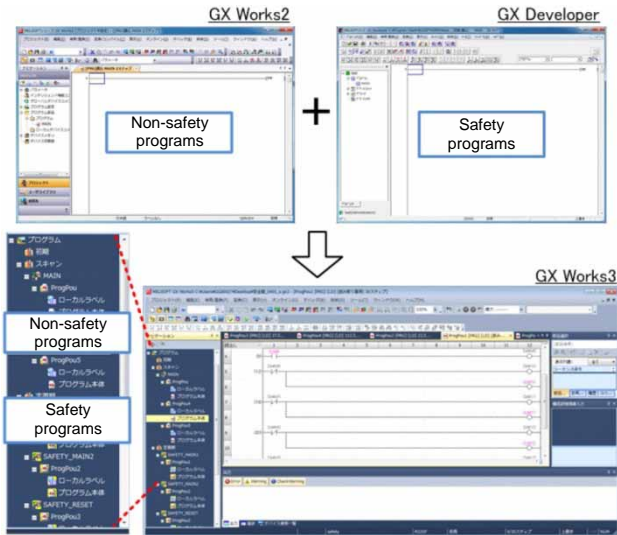

Fig. 2 Integration of development environments

2. Technologies for the Integration of Safety Control and Non-Safety Control

The three main technologies for integrating the safety control and non-safety control are described below.

2.1 Execution of safety control and non-safety control

In order to integrate the safety control and non-safety control, the safety CPU executes both safety programs and non-safety programs.

Conventionally, safety CPUs execute safety program operations and process safety input/output tasks during END processing (Fig. 3 (a)).

However, when non-safety program operations are added to such processing, the extended scan time makes it difficult to ensure the safety input/output response performance. To overcome this disadvantage, the MELSEC iQ-R series safety CPUs use interrupt processing at regular periods (safety cycle time) for

executing safety program operations and processing safety input/output tasks (Fig. 3 (b)).

This allows the safety CPU to execute safety programs and ensure the safety input/output response performance without being affected by the scan time during which non-safety programs are executed.

Furthermore, the MELSEC iQ-R series safety PLCs feature high-speed system buses, enhanced processing performance, and a CC-Link IE Field network, which is faster than CC-Link Safety. These factors help reduce the safety response time (worst-case value) of MELSEC iQ-R series safety PLCs to a level not exceeding one-third of that of existing MELSEC QS series products (Table 1).

Table 1 Comparison of safety response time (worst-case value)

Item	Number of safety remote I/O devices connected						
	2	8	16	32	42	64	120
MELSEC iQ-R Series (CC-Link IE Field)	26	28	30	34	36	45	68
MELSEC QS Series (CC-Link Safety)	103	103	104	126	127	-	-

(Unit: ms)

2.2 Detection of safety control data overridden by the non-safety control unit

With a CPU that executes both safety and non-safety programs, there is a possibility of information in the safety control unit being overridden due to a failure in the non-safety control unit, a software error such as a memory bit error, etc. Safety CPUs are required to detect such overriding.

A MELSEC iQ-R series safety CPU executes safety programs and self-diagnostics using two modules: the safety CPU that performs both safety and non-safety control; and the safety function module that performs only safety control. The safety output values obtained from the program execution results and the

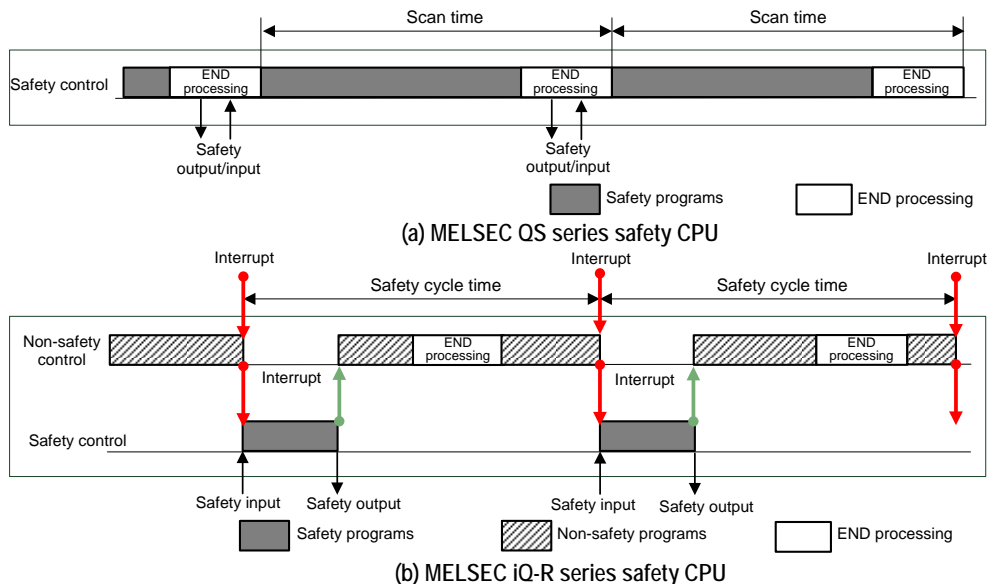

Fig. 3 Execution of safety control and non-safety control

self-diagnostics results are compared (Fig. 4), through which the safety CPU detects portions of data overridden by the non-safety control unit.

2.3 Shutdown of the safety module

Under international safety standards, safety modules are required to shut down on their own and move into a safe state or otherwise take action against a problem or failure with the power supply of the safety control circuit involving failure to continue the safety control.

In the existing MELSEC QS series safety PLCs, with the safety CPU monitoring the internal power supply and system power supply, shutdown is automatically triggered by the cutoff of system power supply by the safety power supply module in the event of voltage failure (Fig. 5 (a)).

The MELSEC iQ-R series safety PLCs are configured with a safety module and non-safety module attached to a base module, and a power supply module

provides the safety and non-safety modules with power. In the event of a problem or failure with the internal power supply of the power supply module or safety module, the safety PLC shuts down the safety module and moves into a safe state.

In this situation, the shutdown of the safety CPU by the safety PLC will terminate the non-safety control performed by the safety CPU. To prevent this in a system responsible for continuing information processing and other non-safety control tasks even after the state shifts to a safe state, it is necessary to adopt a multiple-CPU configuration with safety and non-safety CPUs to allow the continuation of control by the non-safety CPU after the safety CPU shuts down.

For this reason, the safety module monitors the internal power supply and system power supply to cut off the system power supply inside the safety module, thereby shutting down the safety module, in the event of a problem or failure (Fig. 5 (b)). This structure

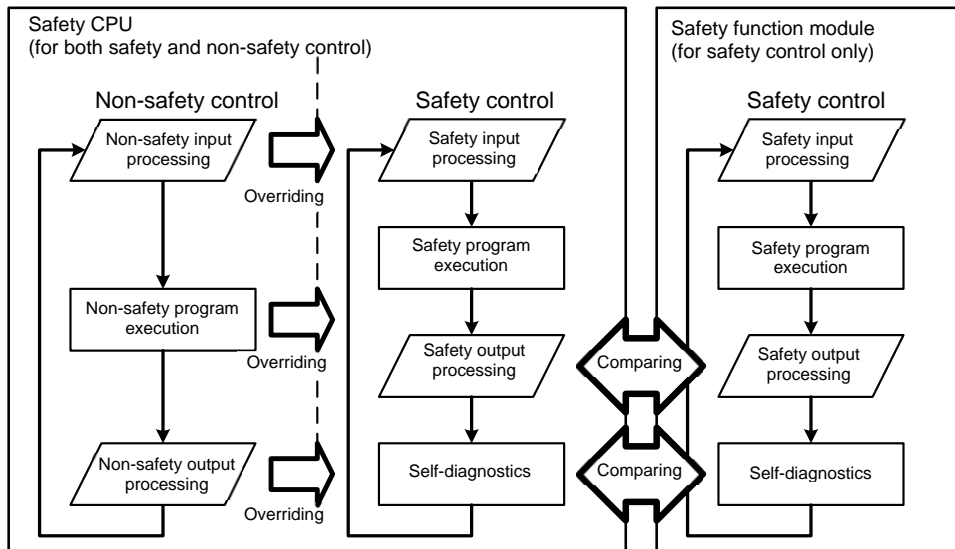

Fig. 4 Detection of safety control data overridden by the non-safety control unit

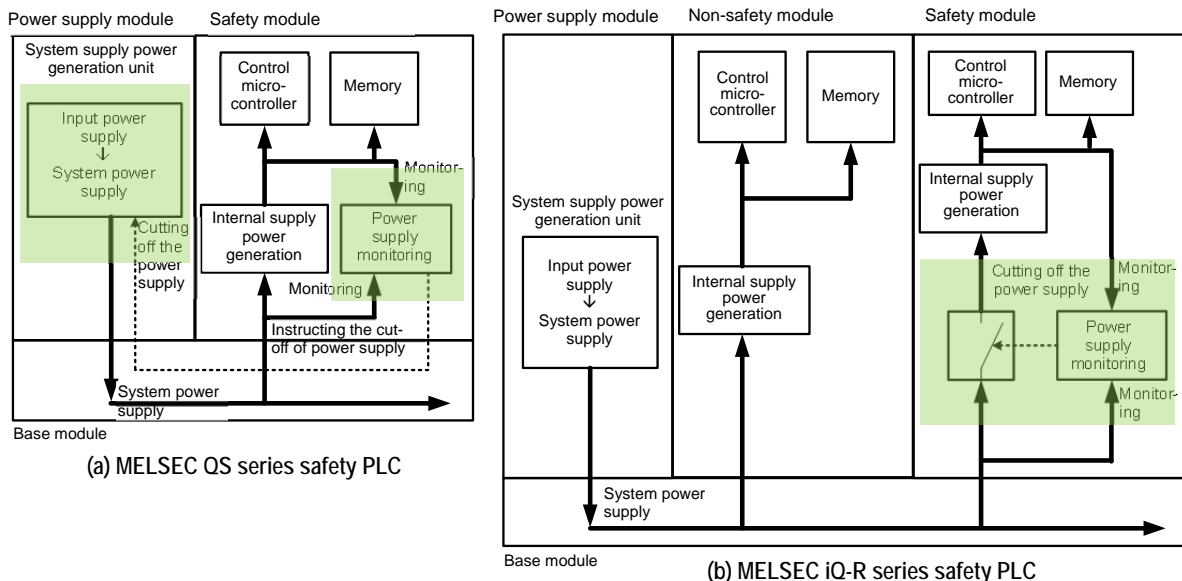

Fig. 5 Cutoff of system power supply

maintains the power supply to the modules other than the safety module, allowing the non-safety module to continue its control. Furthermore, the safety PLC and non-safety PLC can share a power supply module.

3. Conclusion

We described the features of the MELSEC iQ-R series safety PLCs with the integrated safety and non-safety control, as well as the technologies that allow for the integration.

Demands regarding safety PLCs continue to increase, as standards and legal systems are developed. Accordingly, we will continue to improve product capabilities in order to accommodate the diversified demands involving functions, performance, support, etc.

Reference

- (1) Kanamaru H., et al. and Tsuyoshi Mogi: Safety Programmable Controller "MELSEC Safety," Mitsubishi Denki Giho, 81, No. 4, 41-44 (2007)

Development of MELSOFT GX Works3

Authors: Koji Aoyama* and Shogo Morita*

The MELSOFT GX Works3 programmable controller engineering software ("GX Works3") is a development environment with graphical and intuitive operability that allows users to carry out a wide variety of processes including design and maintenance. GX Works3 supports the function block diagram (FBD) and sequential function chart (SFC), meeting the need to support the programming languages specified in the IEC 61131-3 international standard. Although the demand for international standard programming languages has been growing along with globalization of the factory automation (FA) market, previous models have not come with such functions. A motion function has also been added to GX Works3 to meet the demand for engineering environment integration. This article describes these new functions that were not available in models before GX Works3.

1. Support for FBD

FBD is a programming language suitable for describing continuous data processing and consists of function blocks, variables, and connectors. A function block consists of components into which the control is split, and it has input variables and output variables.

The GX Works3 FBD editor has functions for describing a program in an intuitive manner, such as automatically connecting two or more elements when they are brought closer, and cutting out a connected element from the circuit by drag-and-drop it while holding down the Shift key (Fig. 1). FBD executes elements in top-to-bottom order, which would normally make it hard to predict the execution order depending on the arrangement of elements. With GX Works3, the execution order is displayed on the editor, making the

process flow visible.

With the conventional GX Works2 programmable controller engineering software, the editor areas are separated for each ladder block. This means that areas must be added in order to describe multiple ladder blocks (Fig. 2 (a)). With GX Works3, multiple ladder blocks can be arranged freely, making it possible to describe ladder blocks with fewer processes (Fig. 2 (b)).

For developing the FBD supporting function, we have incorporated component software into the editor.

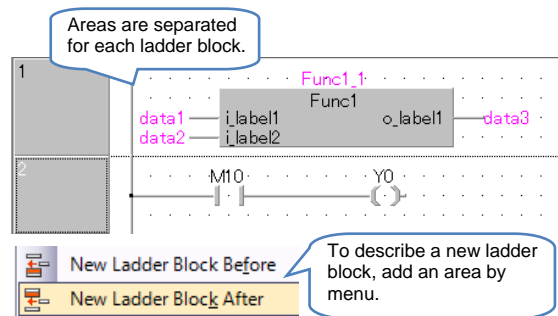

(a) GX Works2

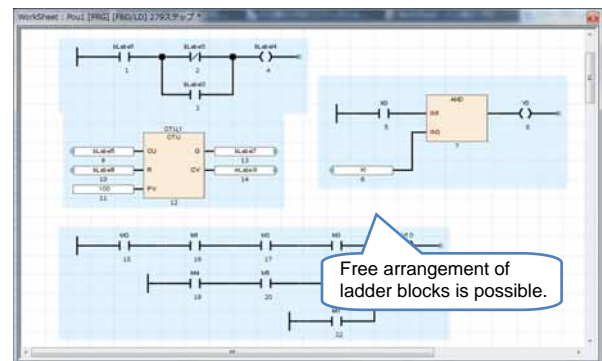

(b) GX Works3

Fig. 2 FBD language editors of GX Works2 and GX Works3

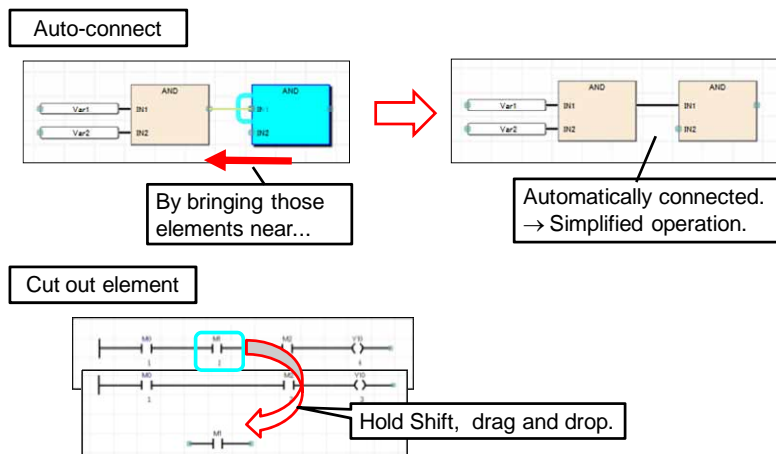

Fig. 1 Intuitive operation

This software is highly customizable and has common basic functions. This allows us to implement GX Works2 compatibility function and to add edit function quickly, achieve ease of use for both GX Works2 users and new users.

2. Support for SFC

SFC, a programming language suitable for describing production line state transition, etc., consists of steps, transitions, actions, and other components. A step represents the state of a process, and a transition represents the condition for moving to the next step. A step contains actual processing called an action. It is possible to also describe a divergence of sequence, which executes only the first-established transitional branch, as well as simultaneous divergence, which executes multiple steps in parallel.

In SFC, a step and a transition appear alternately. In addition, any divergence of sequence and simultaneous divergence require that a convergence associated with each divergence be described. With GX Works2, transition input must be separate from steps, and convergence input must be separate from divergences. In contrast, with GX Works3, when a step, divergence of sequence, or simultaneous divergence is input, a corresponding transition or convergence is automatically input. This ensures that the SFC that a user is working on stays logically correct (Fig. 3).

Furthermore, when checking the operation of a specific process, GX Works2 must start with the initial step operation and then follow the sequence. With a function for operating only the designated steps, GX Works3 is more efficient for debugging and start-up than GX Works2.

Moreover, as ease of use of the editor is important, we significantly improved operability by repeatedly conducting verifications using prototypes. We also

achieved equal operability of FBD and SFC by adopting common component as described in Section 1.

3. Support for Motion Functions

A simple motion module makes it easy to perform advanced motion control, such as synchronous control and electronic cam control, which conventionally requires a dedicated CPU module. GX Works3 supports setting, monitoring, and other functions with respect to the simple motion module. As functions for the simple motion module, we have developed new monitoring functions and expanded the setting and diagnostic functions of the CC-Link IE Field network.

In synchronous control, which is a type of motion control, multiple output axes operate in synchronization with an input axis. When the user wants to check the synchronous control operation, it is difficult to check the entire equipment operation if only the rotational speed and other numerical information can be monitored. The new monitoring function allows the user to easily confirm detailed information such as the entire configuration of the input axis and multiple output axes, state of output axes operation, and speed, on the synchronous control monitor screen (Fig. 4).

CC-Link IE Field Configuration (Fig. 5 (a)) and CC-Link IE Field Diagnostics (Fig. 5 (b)) have also been developed to support the simple motion module. This makes it possible to set a servo amplifier and other connected devices through the same processes as for network modules with GX Works3, although such setup is performed on a dedicated screen with GX Works2. Using CC-Link IE Field Diagnostics, the user can examine, on a single screen, the data link state of devices connected to the simple motion module, as well as check whether there are any problems. These improvements allow easy confirmation of the network configuration and quick troubleshooting.

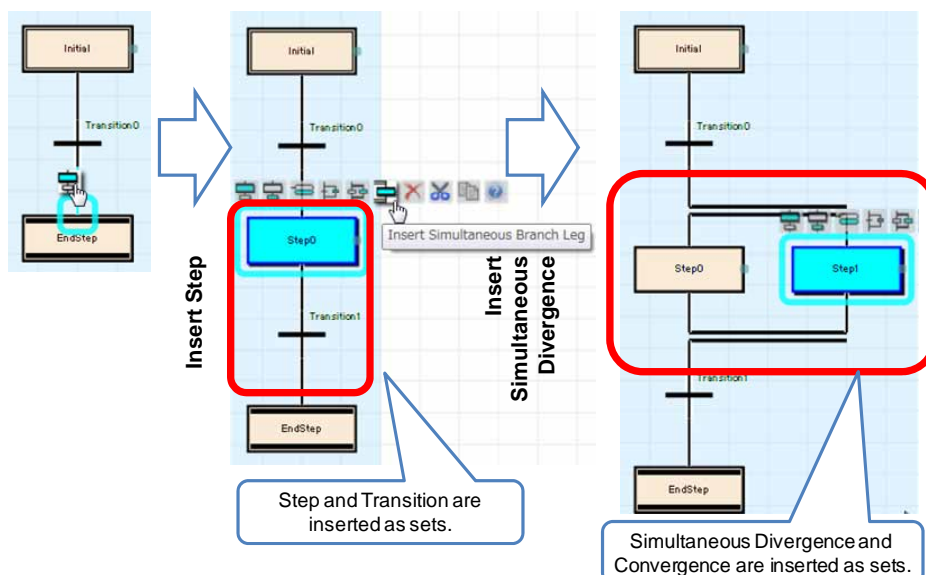

Fig. 3 Edit SFC

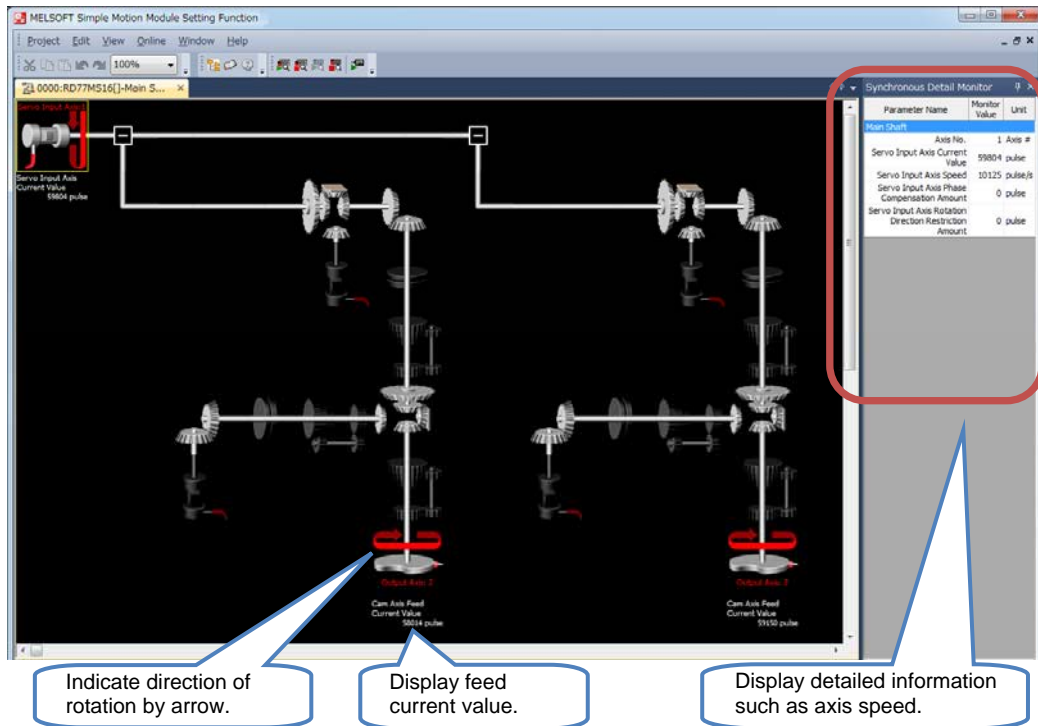

Fig. 4 Synchronous control monitor

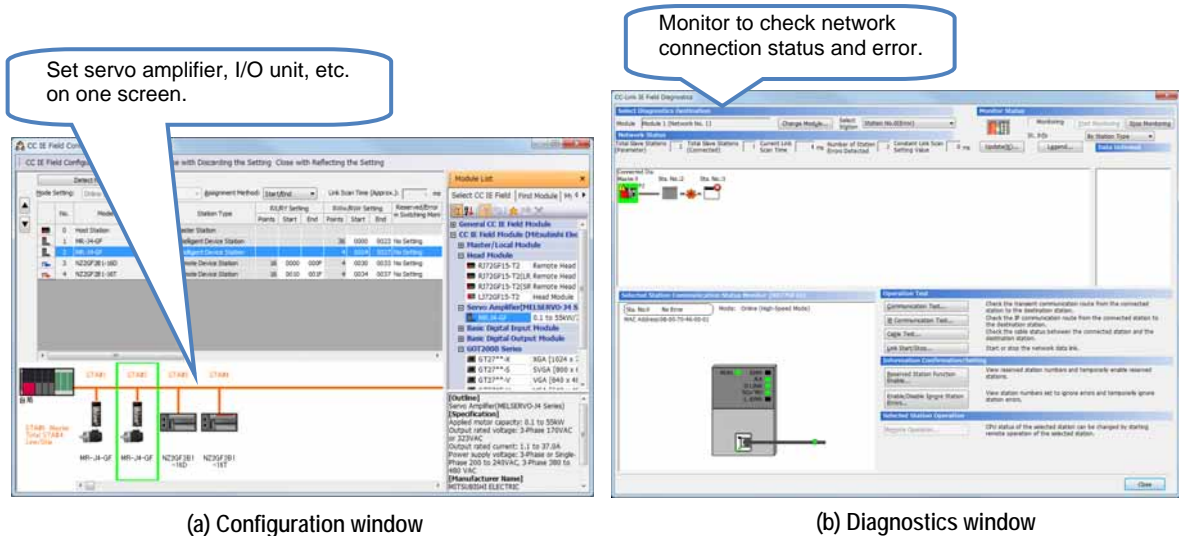

Fig. 5 CC-link IE field configuration and diagnostics

4. Conclusion

We have described three functions provided for GX Works3 in response to globalization of the FA market and engineering environment integration needs. We will continue to develop GX Works3 to reduce engineering costs for customers.

Reference

- (1) Yamaoka T., et al.: Programmable Controller Engineering Software "MELSOFT GX Works3," Mitsubishi Denki Giho, 90, No. 4, 19-22 (2016)

New Function of Graphic Operation Terminal “GOT2000 Series”

Authors: Kei Gomita* and Tomoko Yamada*

Mitsubishi Electric's programmable human-machine interfaces are designed to deliver high performance and reliability, plus the convenience of advanced and unique linkage functions for customers using Mitsubishi factory automation (FA) devices. As a result, the product line is highly evaluated both in Japan and overseas. In view of the growing demand for remote monitoring and maintenance, we recently developed the GOT Mobile function, a solution that uses mobile terminals.

1. Overview

We call programmable human-machine interfaces Graphic Operation Terminals (GOTs). The GOT Mobile function has been developed to allow monitoring and maintenance from mobile terminals based on data information received via the GOT.

Since the release of the initial GOT series, we have continuously upgraded its remote monitoring/maintenance solutions. However, the following issues needed to be resolved.

Issue 1: There are cases in which a GOT cannot be used for remote monitoring/maintenance in a plant, or its use is limited.

Issue 2: The use of a GOT requires the installation of dedicated software on the customer's terminal (PC, etc.), which may make it difficult to introduce the system.

The GOT Mobile function was developed to solve

these issues. Figure 1 shows a schematic view of the function (usage concept).

The GOT Mobile function for remote monitoring and maintenance uses Web technologies. By accessing the GOT Web server from a Web browser running on a PC or mobile terminal, devices can be independently monitored and data information can be operated via the browser on each terminal as done on the GOT. Screens for the mobile terminals are created using GOT engineering software, MELSOFT GT Works3. This enables GT Works3 experts to easily create a screen for a mobile terminal.

2. Features and Applied Technologies

2.1 Simultaneous connection/independent operation of multiple terminals

When performing monitoring or maintenance from a remote location, the operator may display or operate data information different from that viewed at the working site. Also, the data information collected from the plant facilities by a GOT may be used as Andon display information.

With the existing solutions, if monitoring or maintenance is performed by multiple persons, a separate GOT for this purpose is required at the work site, or the monitoring/maintenance must be performed

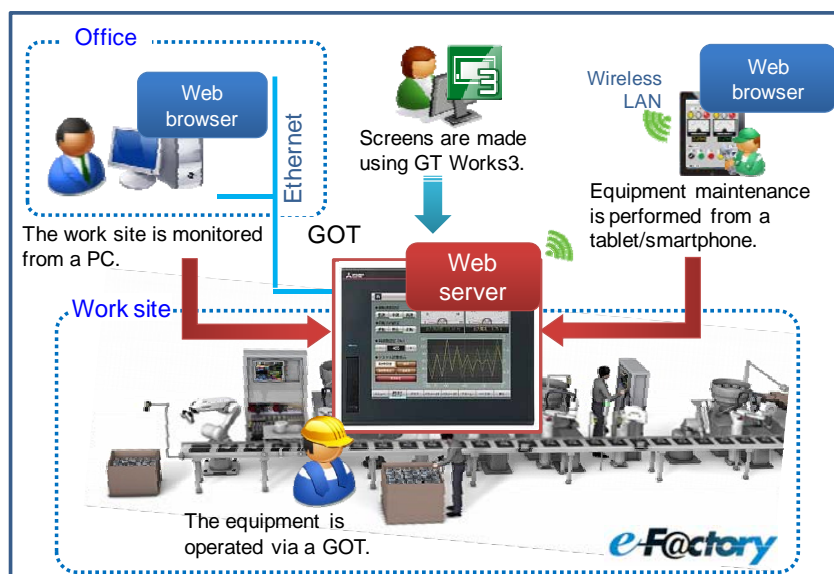

Fig. 1 Overview of GOT Mobile function

when the fixture GOT is not being used at the site. If an Andon display system is installed, another dedicated GOT is needed.

To streamline such GOT use and reduce the number of devices needed, the GOT Mobile function allows the simultaneous connection of multiple mobile terminals to a GOT and an independent screen display for each terminal (Fig. 2).

This function manages the connection status of the mobile terminals connected to a GOT and allows each connected terminal to monitor equipment independently. When operations are performed on the terminals, the information is transmitted to the GOT and is received as independent operations of each terminal.

The GOT uses its internal memory (internal storage device) to retain the information necessary for operation control of the GOT itself, such as the status of monitoring target devices and operation target screen numbers. Upon receiving information on a change in the status or operation performed involving a monitoring target, the GOT updates its internal storage device, and if necessary, updates the screens and the data transmitted and received from connected devices as well.

The GOT Mobile function has a mechanism in which a virtual internal storage device called a GOT Mobile device is used for each mobile terminal, thereby allowing simultaneous connection and independent operation of multiple terminals. More specifically, a section of the GOT's internal storage device is allocated to connected mobile terminals as a GOT Mobile device for each terminal to independently manage the data

information of each terminal.

Figure 3 shows the operation concept when a VGD0, which is one of the GOT Mobile devices, is set to each mobile terminal as the screen changeover device (VGD0: Virtual GOT Data Register #0).

While an example of setting the display screen numbers is shown in the figure, we have adopted a mechanism for managing all data information of each terminal as an independent GOT Mobile device. If the status of the monitoring target changes, the corresponding GOT Mobile device is updated and an update notification is transmitted to the mobile terminals. When an operation notification is transmitted from a mobile terminal, the GOT Mobile device managed by each terminal is updated, and any necessary processes are performed. This has also enabled the simultaneous connection and independent operation of multiple terminals.

2.2 Screen display on Web browsers

We have also developed a mechanism that displays the screens on a Web browser to allow equipment monitoring and data information operation without needing to install a dedicated application. Many companies have introduced restrictions on installing software on information devices and require complicated in-house procedures; instead, a widely-used Web-based solution overcomes the obstacles to introducing the GOT system.

The browser screen display uses standard Web technologies such as Hypertext Markup Language 5

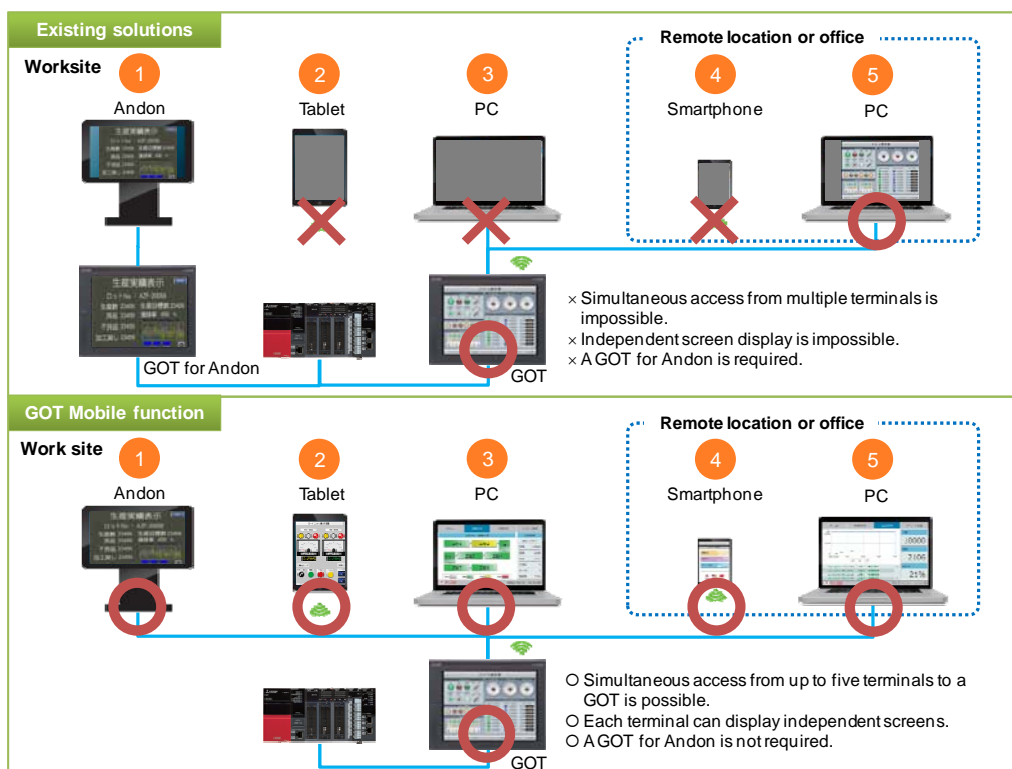

Fig. 2 Connection of multiple mobile device

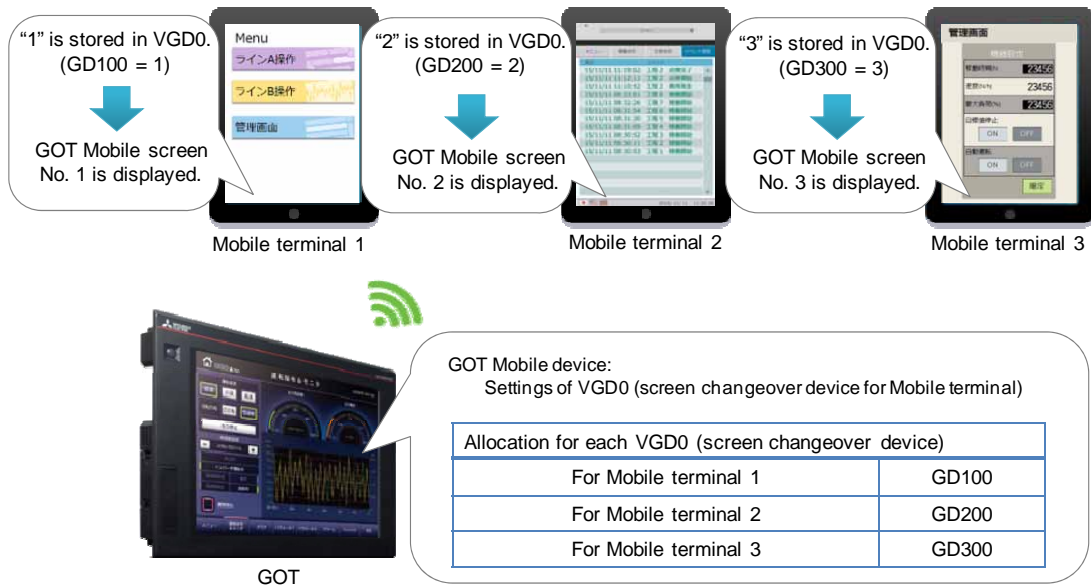

Fig. 3 Example of GOT Mobile device setting for screen transition

(HTML5), Cascading Style Sheets 3 (CSS3), and JavaScript.

2.3 Creation of screens for mobile terminals

The screens displayed using a Web browser are to be created by GT Works3. This is usually done by Web engineers or by using software designed for Web pages. For the GOT Mobile function, screen creation is done by the functional extension of GT Works3, screen creation software for GOTs. This eliminates the need for experience with HTML and other Web technologies. Furthermore, existing screens for the GOT itself can be used.

3. Conclusion

This article described the characteristics and applied technologies of the GOT Mobile function which was newly developed to widen the scope covered by remote solutions. Going forward, we will continue to improve the GOT Mobile function and the linkages with our FA devices. We will also promote solutions provided by product groups and services.

Reference

- (1) Kawai H., et al.: New Model and Function of Graphic Operation Terminal "GOT2000 Series," Mitsubishi Denki Giho, 90, No. 4, 235-238 (2016)

CC-Link IE Field Compatible Servo System

Authors: Hiroto Takei* and Yoshiaki Irifune*

We have developed the MR-J4-GF servo amplifier, RD77GF simple motion module, and engineering environment that support the CC-Link IE Field network. This article describes our initiatives to enhance customer convenience and user friendliness for these new products.

1. Background

Networks that utilize Ethernet¹ technologies are becoming the standard in factory automation (FA) networking. In particular, international standards-compliant open networks that can build connections with a wide variety of products are increasingly considered promising.

The CC-Link IE Field network is an open network that strikes a balance between the synchronization required for motion control and the versatility of Ethernet. It is positioned as a network that plays a central role in Mitsubishi Electric's FA business under the concept of e-F@ctory integrated solutions.

We have developed new products with improved user friendliness to expand the product line of network devices for the CC-Link IE Field network (Fig. 1).

This article outlines the MR-J4-GF servo amplifier, RD77GF simple motion module, and engineering environment that support the CC-Link IE Field network.

2. Characteristics of the CC-Link IE Field Network

The CC-Link IE Field network is an open network

with the versatility of Ethernet that on its own can construct systems offering general I/O control, distributed control between controllers, motion control capable of high-accuracy synchronization, and standards-compliant safety control without another network. In addition, it can implement the real-time data collection required for analyzing big data with the aid of 1-Gbps high-speed, large-capacity communication that allows the real-time transmission of massive amounts of information on production facilities, and the Seamless Message Protocol (SLMP) as well. The SLMP seamlessly links FA devices to IT systems.

Furthermore, the CC-Link IE Field network can be configured in various topologies including line and star. With this network, the wiring becomes freer, and flexible systems can be built according to the installation environment. For example, various devices including a servo amplifier, I/O module, and inverter can be used in a single network, regardless of whether they are for synchronous or asynchronous communication, as shown in Fig. 2.

Information on each device is described in CC-Link Family System Profile Plus (CSP+). Since a network can be easily configured and diagnosed, and a device can be automatically detected from the engineering environment using CSP+ files, system startup and setting changes are easily made. In addition, downtime due to network problems can be reduced.

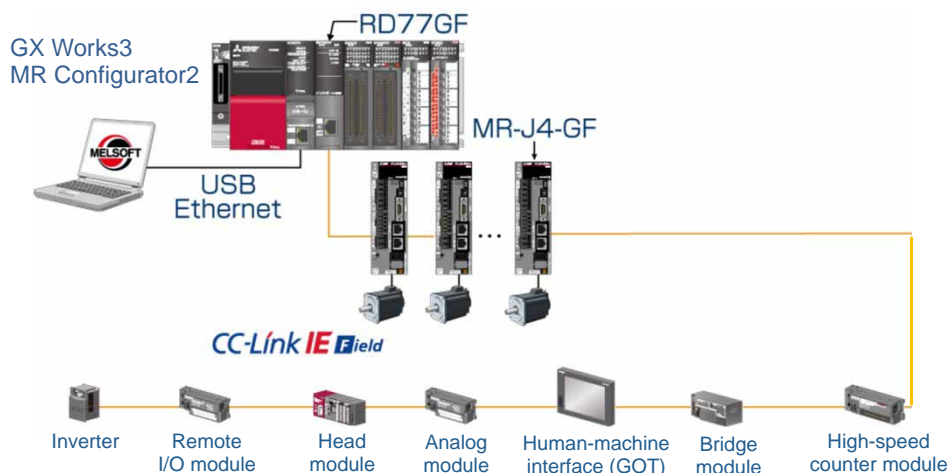

Fig. 1 CC-Link IE Field network-compatible servo system configuration

¹ Ethernet is a registered trademark of Fuji Xerox Co., Ltd.

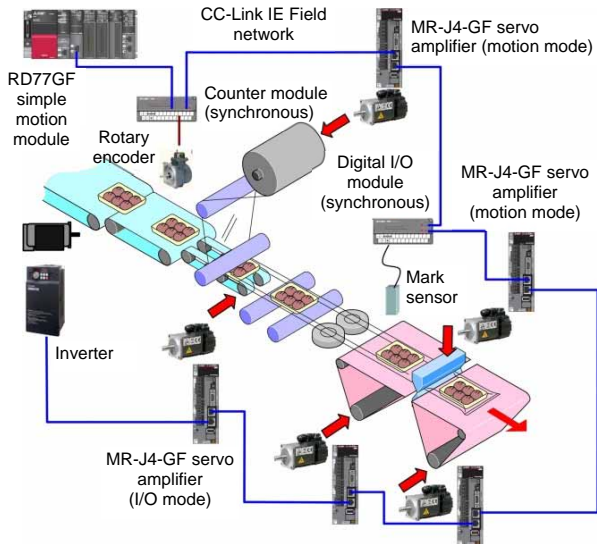

Fig. 2 Example system of a packaging line

3. Product Outline and Main Characteristics of MR-J4-GF

3.1 Supporting both sequential commands and built-in positioning function

The MR-J4-GF is a general-purpose AC servo amplifier that has inherited the basic functions of the MR-J4 series, and has a communication interface compatible with the CC-Link IE Field network.

The MR-J4-GF supports two control modes: the motion mode for the sequential position command control; and the I/O mode for the point table positioning function.

When performing high-accuracy synchronization and complex trajectory control by sequential position command control in combination with a simple motion module, the MR-J4-GF is operated in the motion mode. When performing simple positioning for a conveyance axis, it is operated in the I/O mode.

By selecting either mode depending on the equipment, the controller loads can be distributed, the number of equipment axes can be increased, and the communication cycle can be faster.

The MR-J4-GF also supports SLMP communication, and enables real-time host system monitoring of information on equipment failures or service life, such as friction/vibration data and the number of times the relay turned ON, estimated by the servo amplifier. This contributes to failure prevention and maintenance.

3.2 Backup and restoration

In order to shorten the time required for replacing a device due to failure and other causes, the MR-J4-GF comes with a backup/restoration function that works with a Graphic Operation Terminal (GOT) (Fig. 3).

The backup/restoration function stores the servo

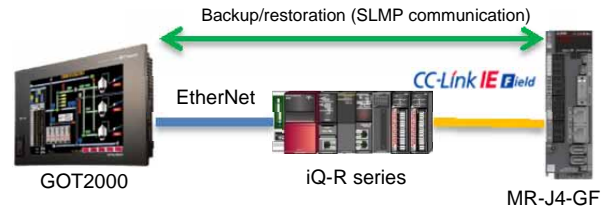

Fig. 3 Parameter backup/restoration using a GOT

amplifier parameters, point table data, and other data on a memory card such as the GOT's SD memory card via SLMP communication, and restores this data when needed, for example, when replacing the servo amplifier. This allows equipment restoration in an environment where a personal computer is not available, such as a manufacturing site.

4. Integration of Motion Control and I/O Control

The RD77GF simple motion module has two integrated functions, the motion control function of the RD77MS simple motion module that is compatible with existing SSCNET III/H servo system networks, and the network function of the RJ71GF11-T2 master/local module for the CC-Link IE Field network. With the number of link device points and a network master function both equivalent to those of RJ71GF11-T2, the RD77GF not only enables customers to perform motion control, but also offers the many advantages of the CC-Link IE Field network including safety communication.

The maximum total number of slave stations for I/O control and servo amplifiers for motion control within a network is 120. This reduces the number of required cables and simplifies installation, thus reducing equipment costs. Furthermore, adopting a two-core System-on-Chip (SoC) (Fig. 4), the RD77GF strikes a good balance between real-time cyclic transmission (synchronous communication) and motion operation processing with the responsiveness of large-capacity transient transmission (of non-punctuality data).

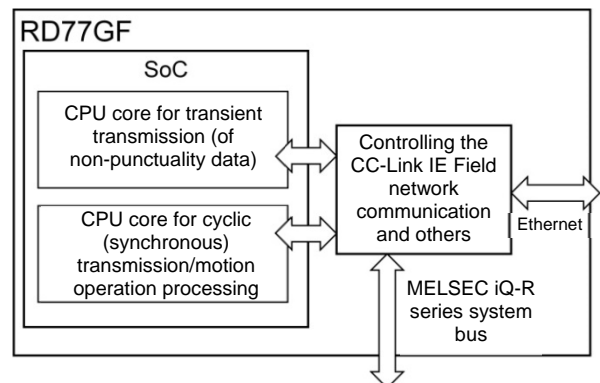
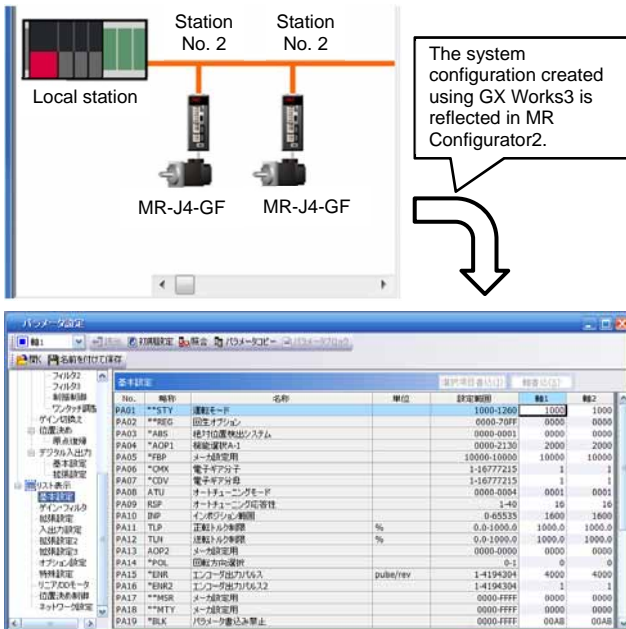

Fig. 4 Block diagram of RD77GF

5. Characteristics of the Engineering Software

5.1 Enhanced engineering software-to-engineering software linkage

MELSOFT GX Works3, which handles system design, programming, and debugging for programmable logic controllers (PLCs), allows the collaborative use of MELSOFT MR Configurator2, which handles setting, adjustment, and maintenance of servo amplifiers. Since a system configuration created by GX Works3 is reflected in MR Configurator2, there is no need for resetting MR Configurator2. The parameter setting screen of MR Configurator2 can be displayed with multiple axes, for each of which the servo parameters can be set on the screen (Fig. 5). Servo parameters set using MR Configurator2 can be centrally managed as a GX Works3 project. The seamless linkage between GX Works3 and MR Configurator2 improves the efficiency of setting work.



Multi-axis MR-J4-GF servo parameters can be set on the screen.

Fig. 5 MR-J4-GF servo parameter setting for multiple axes

5.2 Simulation environment

Through the simulation function of GX Works3, programs can be debugged without using an actual RD77GF or MR-J4-GF. By operating RD77GF's simple motion simulator in combination with a simulator of the PLC's CPU, program behavior in positioning control and synchronous control can be simulated. The simulation results can be checked using a digital oscilloscope. Furthermore, since digital oscilloscopes have a two-dimensional display, they allow intuitive understanding of the trajectories, which significantly improves the efficiency of drive system program debugging (Fig. 6).

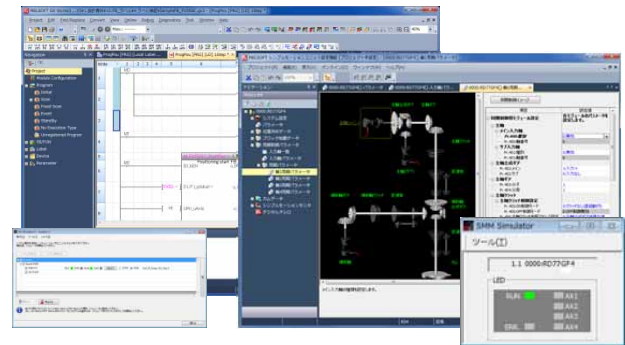

Combined simulation of the PLC and motions

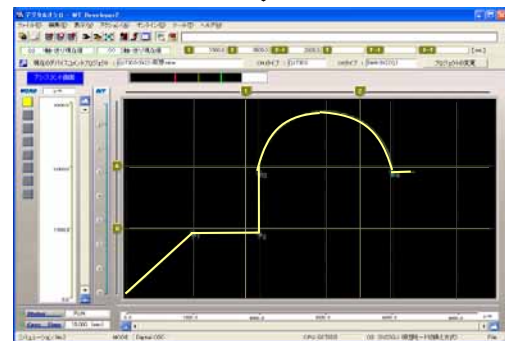

Simulation results are confirmed on a two-dimensional trajectory waveform monitor.

Fig. 6 Simulation function of GX Works3

5.2 Simulation environment

Through the simulation function of GX Works3, programs can be debugged without using an actual RD77GF or MR-J4-GF. By operating RD77GF's simple motion simulator in combination with a simulator of the PLC's CPU, program behavior in positioning control and synchronous control can be simulated. The simulation results can be checked using a digital oscilloscope. Furthermore, since digital oscilloscopes have a two-dimensional display, they allow intuitive understanding of the trajectories, which significantly improves the efficiency of drive system program debugging (Fig. 6).

6. Conclusion

In this article, we presented the newly developed MR-J4-GF servo amplifier, RD77GF simple motion module, and engineering environment that support the CC-Link IE Field network, together with our initiatives to provide higher customer convenience and user friendliness. Going forward, we will enhance the linkage with GOTs among other improvements to broaden the scope of application of these products.

Industrial Robots “MELFA FR Series”

Author: Yoshitaka Kumagai*

Recent years have seen a growing need for flexibility in production lines through the effective use of IoT and human-robot collaboration in which industrial robots work alongside operators on the factory floor. To this end, we have developed the MELFA FR industrial robot series, which features higher performance than previous models, strengthened e-F@ctory/FA equipment linkage, enhanced safety functions, and improved intelligent robot technologies.

1. Background of the Development

As customer needs diversify along with changes in the social environment, the prevailing mass production of a few varieties of products is shifting to small-lot production of many varieties of products, or to variable quantity production of variable products. Many manufacturers take the modular production approach, using human hands to respond to the situation. However, the current modular production involves several issues that must be addressed, including a lack of workers, high labor cost, and variation in product quality due to human error. This increases the demand for automated modular production using robots. In addition, there is a need for flexibility in production lines by effectively using IoT and human-robot collaboration in which robots work alongside operators on the factory floor. In response to these market demands, we have developed the MELFA FR industrial robot series with higher basic performance than previous models, strengthened e-F@ctory/FA equipment linkage, enhanced safety functions, and improved intelligent robot technologies (Fig. 1).



Fig. 1 MELFA FR industrial robot series

2. Features of the MELFA FR Series

2.1 Improved basic performance

2.1.1 High-speed control cycle and communication cycle

The MELFA FR series has a greater path accuracy achieved by strengthening the controller performance and shortening the control cycle to half that of existing models. A new robot CPU compatible with the MELSEC iQ-R series has been developed as well. The improved system bus performance enables CPU communication four times faster than existing CPUs, allowing for faster operation of production equipment.

2.1.2 Improved absolute position accuracy

Robot arms expand and contract due to heat from motors. This may cause a positional shift when the same command for the same position is given immediately after the motor is powered on and after its warm-up operation. For this reason, particularly at work sites where accuracy is essential, warm-up operation is recommended to ensure that the temperature of the robot arm is constant before starting work. The MELFA FR series includes a function to measure the robot arm temperature and automatically compensate for thermal expansion that causes positional shifts. Robot arm temperature is changed by the motor heat, making an arm expand and contract according to the temperature. This function has reduced the margin of positional error due to thermal expansion of arms to approximately one-fifth, allowing highly accurate arm movements immediately after powering on without warming up the robot. If a temperature difference occurs due to seasonal or temporary reasons, the size of misalignment can be suppressed (Fig. 2).

2.2 Strengthened e-F@ctory/FA equipment linkage

The MELFA FR series was also designed with the following functions to enable Mitsubishi Electric e-F@ctory host information systems and FA equipment to obtain internal information on the robots, and to allow the robots to receive instructions.

2.2.1 Device number designation function

Conventionally, only information that is predetermined by the robot system, such as the robots' present positions and current values, is allocated to the

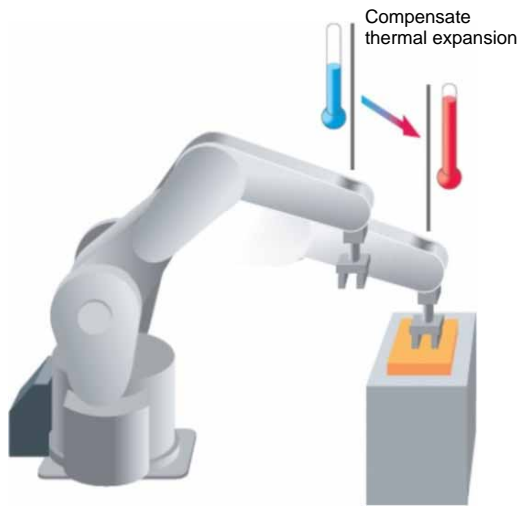

Fig. 2 Compensating for thermal expansion of an arm

device memories in the robot controller. FA equipment including a Graphic Operation Terminal (GOT) gains access to the robot system information through device memories. This means that in order for FA equipment to access arbitrary user information such as production quantity and quality stored in the robot program, the information must be written to the device in the robot controller. The MELFA FR series allows the variables (stored arbitrary user information) in the program to be directly designated to device memories. This has made it easier to share information between the robots and the FA equipment (Fig. 3).

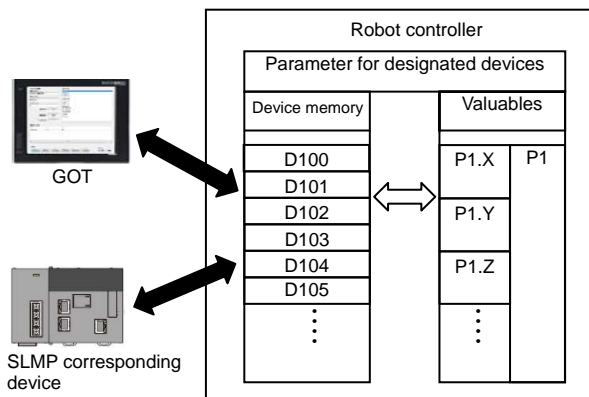

Fig. 3 Device number designation function

2.2.2 Supporting SLMP

The MELFA FR series supports Seamless Message Protocol (SLMP). SLMP allows for communication between applications in the network regardless of layers/boundaries including from the host to lower-order systems. Combined with the device number designation function, this allows FA equipment to seamlessly exchange internal information on each robot and instructions given to robots with high-order information systems (Fig. 4).

2.3 Improved safety functions

There is an increasing need for human-robot collaboration in which robots work alongside operators on the factory floor. To achieve this, robots with safety functions and risk assessment for system operation are indispensable. The MELFA FR series is the first of our industrial robots to include the Safe Operating Stop (SOS) function and Safe Stop 2 (SS2) function as required by the latest safety standards (EN61800-5-2, IEC60204-1). In addition, the existing Safety-Limited Speed (SLS) and Safety-Limited Position (SLP) functions have been strengthened for the MELFA FR series.

2.3.1 Strengthened Safety-Limited Speed (SLS) function

Monitoring the speed of movements is required for all parts of industrial robots, not just the hands, since robots take positions in which the joints move quickly while the hands move slowly, and it is difficult to instantly predict the path of each joint movement. With the MELFA FR series, up to four freely selected locations of a robot can be designated as subjects of safety-limited speed monitoring in addition to the hand of the robot arm. The increase in number of safety-limited speed monitoring subjects helps prevent unexpected high-speed movements of joints and other parts, rendering a more safely constructed robot system compared to that without the MELFA FR series (Fig. 5).

2.3.2 Improved Safety-Limited Position function

Existing models are not capable of designating a region in relation to peripheral equipment in a robot cell, since they can only designate the opposite side of a free plane as a region closed to robot access. With the MELFA FR series, a user-defined rectangular parallelepiped space can be designated as being closed to robot access, making it simpler and more flexible to divide a work area into safe and non-safe regions (Fig. 6).

2.3.3 Safety logic editing screen

We have developed a logic edit function for the safety signal that defines the operating conditions (logic) of the safety monitoring function in the robot controller. Unlike existing models that require a safety programmable logic controller, the MELFA FR series uses the safety logic edit function for robots. This facilitates the construction and operation of a safety system, reducing system costs and design time (Fig. 7).

2.4 Improved intelligent robot technologies

2.4.1 Improvement of force sensor data acquisition ability

The speed of data acquisition of the force sensor has been increased to eight times that of existing

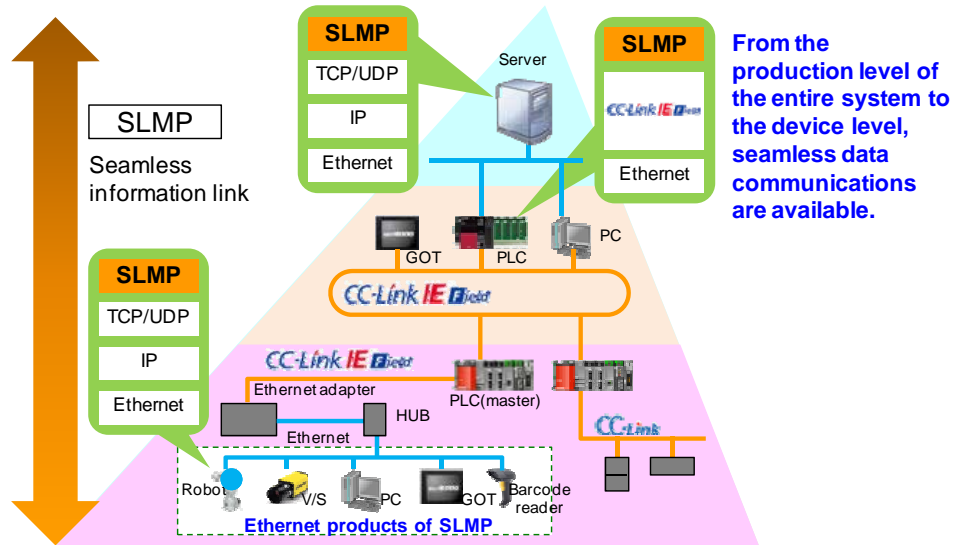

Fig. 4 SLMP (Seamless Message Protocol)

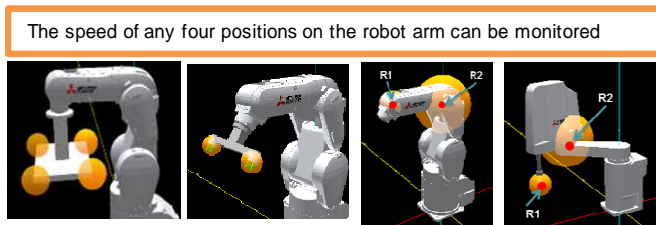
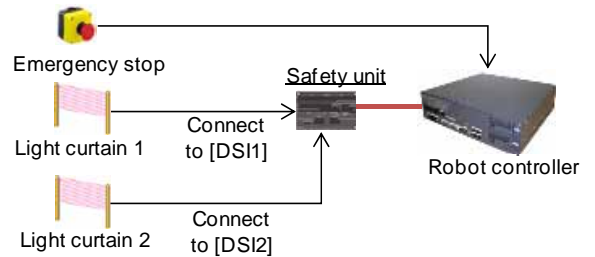

Fig. 5 Expansion of safety-limited speed monitoring coverage



To enable the safe speed monitoring if sensors 1 and 2 both of intrusion detection, such as logic can be set.

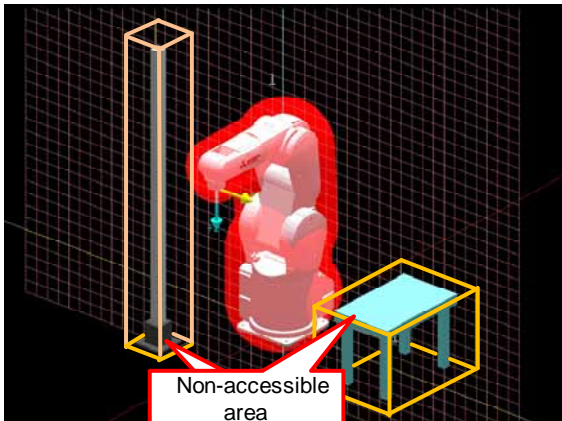

Fig. 6 Expansion of safety-limited position monitoring coverage

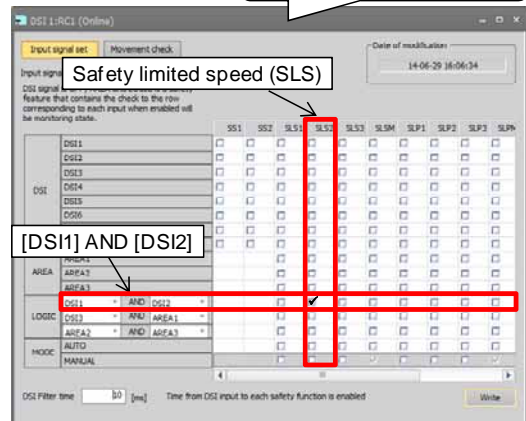

Fig. 7 Edit screen of safety logic

models in order to obtain detailed data. This makes quality data more accurate. Furthermore, since the control speed of the robot controller has been doubled, processes such as mating and machining can be faster and work quality can be improved.

2.4.2 Work coordinate calibration function

Using the information from the vision sensor (eye) installed in the hand of the robot arm, we have achieved a function that easily allows calibration of the robot and work coordinates (Fig. 8).

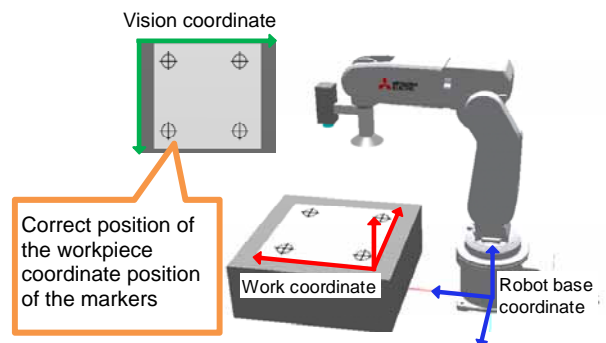

Fig. 8 Calibration of work coordinates

This is used to correct positional misalignment incidental to such cases as relocating a robot and placing a robot on an automated guided vehicle (AGV), improving the working stability.

3. Future initiatives

In this article, we described the following features of the MELFA FR series industrial robots: higher basic performance than previous models, strengthened e-F@ctory/FA equipment linkage, enhanced safety functions, and improved intelligent robot technologies.

Today, there is a growing shift toward next-generation factories in the age of the Industrial Internet of Things in the manufacturing sector worldwide. We will continuously strive to respond to growing demands in this process by incorporating more IoT and artificial intelligence (AI) technologies into our products to improve their performance.

Expansion of Circuit Breaker Lineup for High-Voltage Direct Current

Author: Nobuo Miyoshi*











Due to growing concerns over global warming, and in the wake of the Great East Japan Earthquake, the availability and implementation of power generation systems using renewable energy such as solar, wind, hydro, geothermal, and biomass energy have increased in Japan. Particularly, the introduction of photovoltaic generation systems ("PV systems"), representing clean energy systems, has been promoted on a large scale, with the aid of legal/subsidy systems provided by the national and local governments, improved solar panel performance, etc. Since the renewable energy feed-in tariff scheme was introduced in July 2012, large-capacity systems exceeding 1 MW have been actively constructed in various locations, which has led to the demand for switching and protection devices against high-voltage direct current. While Mitsubishi Electric has expanded the lineup of devices not exceeding 1,000 V DC, we have developed high-voltage DC circuit breakers of 125 AF and 250 AF that can be used for 1,000 V DC systems, in order to strengthen the lineup of high-voltage systems as well.

AF models, the DC circuit breakers and switches adopt a breaking method using a permanent magnet for magnetic arc control. The KB-HD and KB-HDA DC switches used for string combiner boxes adopt the ARC SWEEPER method, one of our own technologies. For the 125 and 250 AF DC circuit breakers used for string combiner boxes and array combiner boxes, steps were taken to separate an arc that is moved to the splitter plates by using a permanent magnet placed in the vicinity of the contact space, and to cool the arc. The newly developed HDVA series for 1,000 V DC has been made available for use at such high voltage by increasing the number of 250 V poles of an existing 750 V DC circuit breaker from three to four. The permanent magnet arrangement in the arc-extinguishing chambers of the HDVA series is an improved form suitable for use at the high voltage of that of the HDV series for 600 V DC released earlier. This is described in detail in the next section. Lastly, the 400 to 800 AF circuit breakers, which is the HDW series to be installed on power conditioners, have a large circuit breaker case, allowing sufficient contact opening distance to be obtained. For this reason, the 400 to 800 AF circuit breakers adopt an arc controlling method using the attractive force of magnetic splitter plates instead of a permanent magnet.

1. Features of Our High-Voltage DC Circuit Breakers and Switches

Table 1 shows the lineup of our high-voltage DC circuit breaker/switch models. Except for the 400 to 800

Table 1 Lineup of circuit breakers and switches for direct current

	Maximum voltage		
	600 V DC	750 V DC	1,000 V DC
Power conditioner panel (High capacity)	NF400-SW, NF630-SW NF800-SDW, NF1250-SDW		NF400-HDW NF800-HDW
Power conditioner panel (Intermediate capacity)	NF125-HDV NF250-HDV 	NF125-HDVA NF250-HDVA 	<div style="border: 2px solid pink; padding: 5px; text-align: center;"> <p>New releases: NF125-HDVA NF250-HDVA</p>  </div>
Power conditioner panel (Low capacity)	NF63-HDV 	NF125-HDVA NF250-HDVA 	
Array combiner box	NF63-HDV NF125-HDV NF250-HDV 	NF125-HDVA NF250-HDVA 	
String combiner box	KB-HD 	KB-HDA 	

2. 125 AF and 250 AF DC Circuit Breakers for 1,000 V DC

Figure 1 shows a cross-sectional view of a side of the arc-extinguishing chamber of the HDVA series. Figure 2 shows a perspective view of the arc-extinguishing device installed in the chamber. In Fig. 1, the movable element is in the position to open the pole (contact OFF position). When breaking the circuit, the arc generated between the contacts is taken into the arc-extinguishing device in which U-shaped splitter plates are arranged in layers as shown in the upper left of the figure. The arc-extinguishing chamber of the HDVA series is based on that of the HDV series for 600 V DC. In order to use the existing arc-extinguishing chamber for the new series, it was necessary to increase the arc voltage from 200 V to 250 V generated for each pole in order to increase the voltage to be interrupted. The details of the improvements made regarding the high- and low-current regions for increasing the arc voltage are described below.

(1) Improvement of the breaking performance in the high-current region

When an arc is moved into the arc-extinguishing device, in the high-current region, electromagnetic force can be generated for the arc using the self-magnetic field of the current. The challenging part is to make the arc voltage generated by the arc-extinguishing device

higher. In general, the voltage drop per splitter plate is approx. 20 to 30 V. The arc voltage when an arc is taken into the arc-extinguishing device depends on the number of splitter plates. In view of this, the number of splitter plates in the HDVA series was increased from nine to twelve as shown in Fig. 1. To address the bridging caused by the increased number of splitter plates, the thickness of and distance between the splitter plates have been optimized, thereby allowing high-voltage high current to be broken.

(2) Improvement of the breaking performance in the low-current region

In the low-current region, an effective method for increasing the arc voltage is to stretch the arc in the contact space to increase the resistance in the arc. However, with a low current, the self-magnetic field of the current cannot be used to control an arc. Instead, arcs are generally controlled using the magnetic field of a permanent magnet to generate electromagnetic force to the arcs. In the HDV series, a permanent magnet is placed on one side of the contact space with a magnetic pole facing the stationary contact. This causes the current direction to turn when the circuit breaker is reversely connected, disabling the arc from being moved to the splitter plates and resulting in an arc voltage drop. As shown in Fig. 2, in the HDVA series, two permanent magnets are placed on both sides of the contact space to double the magnetic flux density for the interlinkage with an arc. This enables the HDVA series to stretch the arcs to a greater degree compared to the existing series. Figure 3 and Figure 4 show the magnetic field distribution in the arc-extinguishing device and the form of an arc stretched in the contact space by the electromagnetic force, respectively. The top views are seen in the direction from above the arc-extinguishing device toward the stator, and the front views are seen in the direction from the movable element to the arc-extinguishing device. Figure 3 shows a standard connection state in which the current flows in the direction from the stator to the movable element, while Fig. 4 shows a reverse connection state in which the current flows in the direction from the movable element to the stator. Permanent magnets A and B are protected and supported with a thermosetting resin for protection from high-temperature arcs. Each magnet is arranged with the north pole facing the contact space. When the lines of magnetic force (A1, A2, B1, and B2) are interlinked with an arc, electromagnetic force is generated perpendicularly to each line of magnetic force. When the circuit breaker is connected in a standard manner, lines A2 and B1 act in the direction in which an arc is moved toward the boundary of the north and south poles, while A1 and B2 act in the direction in which an arc is moved away from the boundary of the north and south poles. As a result, line B1 repels the arc

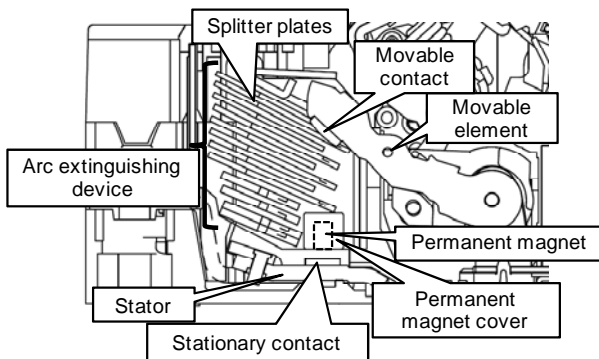

Fig. 1 Cross-section of the HDVA series arc-extinguishing device (open position)

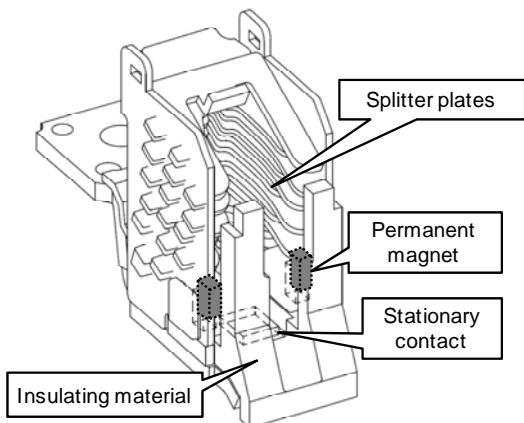

Fig. 2 Structure of the HDVA series arc-extinguishing device

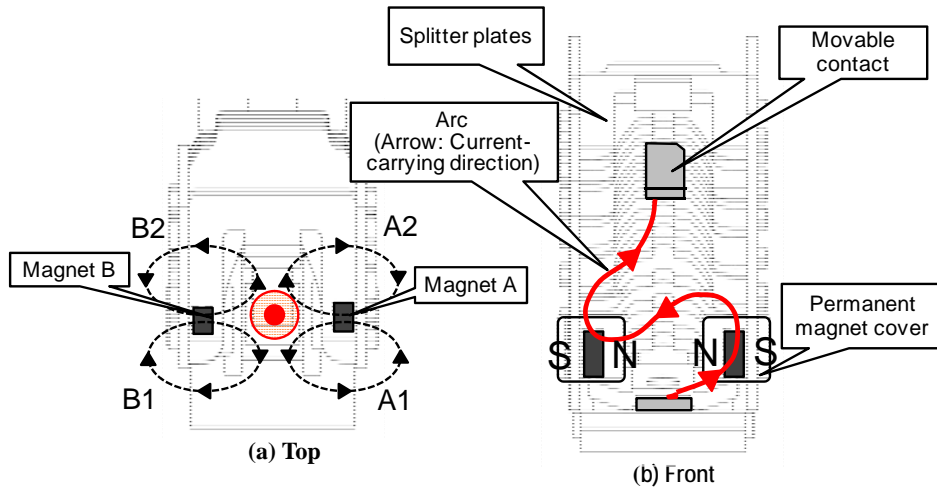

Fig. 3 Magnetic field and driving direction of the arc (standard connection condition)

to make it move in the direction of A1 toward permanent magnet A. Line A2 repels the arc to make it move in the direction of B2 toward permanent magnet B.

Under such conditions, when the circuit breaker is connected in a standard manner and the movable element is in the position to completely open the pole, the arc generated from the stationary contact is moved to the A1 side of permanent magnet A and strikes the permanent magnet cover. The exposure of the permanent magnet cover to the high-temperature arc produces ablation gas. The ablation gas compresses and cools the arc, leading to an increase in the arc voltage. After striking the cover of permanent magnet A, the arc is moved to permanent magnet B. After striking the cover of permanent magnet B, the arc reaches the movable contact (Fig. 3 (b)). When the circuit breaker is connected in a reverse manner as well, the arc, moving opposite to the behavior in the case of standard connection, travels from the movable contact to the stationary contact through the processes of being stretched and striking the permanent magnet covers (Fig. 4 (b)).

As explained above, the arc voltage is further increased by stretching an arc and causing it to strike the permanent magnet cover both when the circuit breaker is connected in a standard manner and when it is connected in a reverse manner, and can thus break high-voltage low current.

3. Conclusion

We have described the products launched on the PV market as the expansion of the existing lineup of high-voltage DC circuit breakers. Going forward, while monitoring the trends of PV system demand for switching and protection devices that withstand even higher voltage and of the DC power distribution market, we will strive to expand product lines other than those of DC switches and circuit breakers, and to apply the arc control technology findings obtained through the series of DC switch and circuit breaker development processes to other product lines.

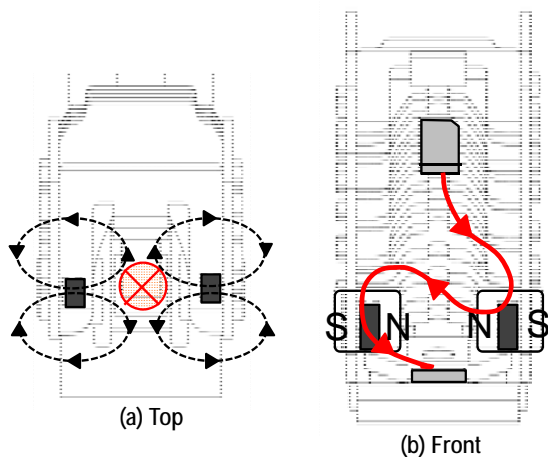

Fig. 4 Magnetic field and driving direction of the arc (reverse connection condition)

