

Dec.2012 / Vol.140

MITSUBISHI ELECTRIC

# ADVANCE

Environmental Technologies for Becoming a Global, Leading Green Company

• **Editorial-Chief**

*Shoichiro Hara*

• **Editorial Advisors**

*Toshio Masujima  
Maki Ikegami  
Kazuhiro Oka  
Tetsuji Sorita  
Chikao Nishida  
Hideaki Okada  
Takahiro Nishikawa  
Tetsuyuki Yanase  
Ichiro Fujii  
Tatsuya Ichihashi  
Masato Nagasawa  
Daisuke Kawai  
Keiichiro Tsuchiya  
Toshitaka Aoyagi*

• **Vol. 140 Feature Articles Editor**

*Motohiro Tanaka*

• **Editorial Inquiries**

*Kazuhiro Oka  
Corporate Total Productivity Management  
& Environmental Programs  
Fax +81-3-3218-2465*

• **Product Inquiries**

*Motohiro Tanaka  
Corporate Environmental Sustainability  
Group  
Fax +81-3-3218-2465*

**Mitsubishi Electric Advance** is published on line quarterly by Mitsubishi Electric Corporation.  
Copyright © 2012 by Mitsubishi Electric Corporation; all rights reserved.  
Printed in Japan.

The company names and product names described herein are the trademarks or registered trademarks of the respective companies.

**CONTENTS**

**Technical Reports**

Overview .....	1
<i>by Tomohiko Nambara</i>	
Power Saving by Demand Monitoring System .....	2
<i>by Akiko Toyokuni and Shigemitsu Fujiwara</i>	
Factory Energy Management System Using Production Information .....	7
<i>by Hiroyuki Makita, Yuko Shida and Naomichi Nozue</i>	
Solution of IT System for Management of Chemical Substances Contained in Products .....	12
<i>by Hiroko Higuma</i>	
Advanced Recycling Technologies for Plastics and Rare Earth Magnets Used in Home Appliances .....	16
<i>by Yasushi Uehara, Muneaki Mukuda and Takeshi Tsukasaki</i>	

# Overview



Author: *Tomohiko Nambara\**

The Mitsubishi Electric Group has formulated mid-term environmental plans every three years, and we are now in the first year of the "*7th Environmental Plan*." In our environmental plans, we mainly address the reduction of environmental impact caused by "production processes"; and further, in the *7th Environmental Plan* we put emphasis on "environmental contribution through products." As a manufacturer of general electrical machinery, Mitsubishi Electric Group's businesses include a wide range of energy-using products and services for industrial, public, transportation, home, and many other sectors around the world. Improving the energy efficiency of these products and services would significantly reduce CO<sub>2</sub> emissions throughout all of society, on a much larger scale than CO<sub>2</sub> emissions during production. In addition, regarding our role in creating a low-carbon society, the design of "products" plays a critical role for establishing a recycling-based society. The *7th Environmental Plan* aims to increase awareness among both society and Mitsubishi Electric on the importance and scale of the contribution to an environment-conscious society through products and services, resulting in the development of economic activities in harmony with the reduction of environmental impact. This special issue introduces Mitsubishi Electric's proprietary product technologies that are helping to create a low-carbon and recycling-based society.

# Power Saving by Demand Monitoring System

Authors: Akiko Toyokuni\* and Shigemitsu Fujiwara\*\*

Demand monitoring equipment is installed in each factory or office, and is linked to the Mitsubishi Electric Head Office via the intranet, where a centralized monitoring server provides comprehensive control (Fig. 1). The multi-demand viewer uses its wide-area control function to collect electric power data from each site in real time, and sends out an alert e-mail when there is a high probability of exceeding the target level.

## 1. Introduction

As an aftereffect of the Great East Japan Earthquake, the electric power supply was expected to worsen in the service areas of Tokyo Electric Power Co. and Tohoku Electric Power Co., and thus in the summer of 2011, the Japanese government issued an ordinance on the restriction of electricity use based on Article 27 of the *Electricity Business Act*. This ordinance mandated that high-volume business users with a contract demand of 500 kW or greater must reduce their use of electricity from 9 a.m. to 8 p.m. on weekdays by 15% from the peak level in the previous summer.

Meanwhile, Mitsubishi Electric announced a plan to reduce demand power (demand) during peak hours. This plan exceeds the government ordinance of 15%; Mitsubishi Electric Group's 18 business sites, which are subject to the government ordinance on the restriction of electricity use, would reduce the total demand by 25% from the previous year. To achieve this target, each site has implemented drastic electricity-saving measures, and the Head Office has introduced a demand monitoring system to establish a centralized

control scheme for the demand power of all business sites.

This paper describes the efforts for reducing power consumption through the demand control system: its implementation, operation, management, and future issues.

## 2. Demand Control

### 2.1 What is demand?

Demand power (demand) is defined as the average electric power over 30 minutes, which is calculated by differentiating the electric energy over 30 minutes with respect to time. This time interval of 30 minutes is called the "demand period."

The basic charge for electricity is calculated from the contract demand, which is determined based on the maximum demand in the last 12 months. In the case of high-volume business users, if the demand exceeds the contract demand, the user is obliged to pay an extra charge as a penalty. That is, demand control is also important from the viewpoint of electricity cost. The integral of the demand (kW) over time gives the electric energy (kWh), and thus it is also useful for energy-saving purposes.

### 2.2 Electric power control by joint-use restriction scheme

The government ordinance on the restriction of electricity use provides the option of adopting the "joint-use restriction scheme," which allows a

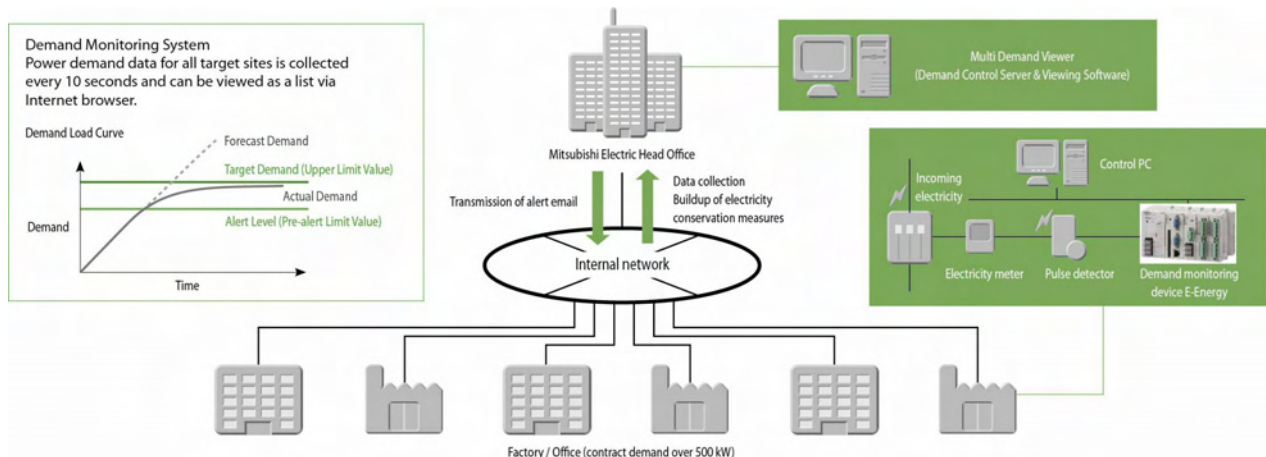

Fig. 1 Overview of Mitsubishi Electric Group's power demand control initiative

high-volume business user to coordinate its multiple sites to achieve joint reduction of the peak demand. Mitsubishi Electric employed this scheme to reduce the total amount from all sites.

The joint-use restriction scheme provides two advantages.

First, as long as the total electricity use remains below the limit as defined by this scheme, it is acceptable for a site to exceed its assigned limit value, jointly supplementing the shortfall of the site that would be unable to attain the target of 15% reduction by itself.

Second, joint-use restriction makes it possible for the business user to take comprehensive power-saving measures by fully utilizing individual conditions, such as holidays, determined for each site and supply-demand adjustment contract.

In the joint-use restriction scheme, the peak reference value is defined as the maximum value of the total sum of all sites in the reference year. In general, the peak at individual sites occurs on different days and times, and thus the total sum of the individual peak values within certain hours on certain days is smaller than the simple sum of individual peak values (peak power) (Fig. 2). The greater the number of sites and the wider the relevant area are, the better the effect that can be expected from the deviation in peak day and time. Therefore, Mitsubishi Electric Group pursued operations that take full advantage of the joint-use restriction scheme.

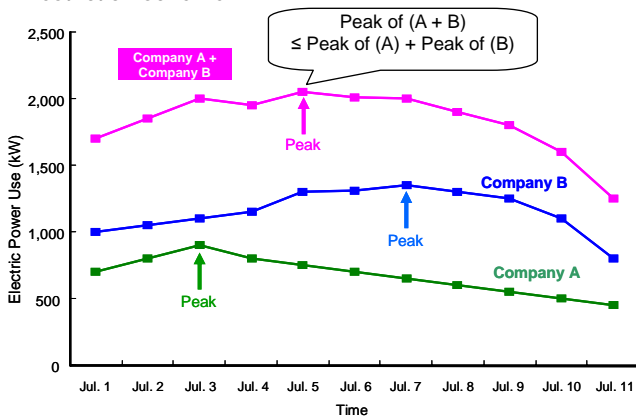

Fig. 2 Peak reference value in the joint-use restriction scheme

### 2.3 Activities of Mitsubishi Electric Group

Based on the joint-use restriction scheme, Mitsubishi Electric Group introduced the concept of jointly restricting the total sum of all sites, and has taken electricity conservation measures toward the goal of 25% reduction from the level in 2010. Within the Tokyo and Tohoku Electric Power service areas, each business site has implemented as many power-saving measures as possible including: restricting the use of lighting, air conditioners and other electric devices, shifting site operations to holidays and nights, changing and reduc-

ing the operation hours of large machinery for production and testing, introducing in-house generators and photovoltaic power generation systems, and relocating and/or rearranging workspaces.

In addition, the Head Office introduced a demand monitoring system for real-time data collection and centralized monitoring of the demand of all business sites. Apart from the legal limit of the ordinance on the restriction of electricity use, a target value for the total demand was set for each group of sites within either the Tokyo or Tohoku Electric Power service area; and an individual target demand was also set for each site in proportion to the respective attainable power reduction level. When it is indicated that the total demand will exceed the limit, an alert e-mail is automatically sent out from the system and emergency measures are instructed over the phone to coordinate the sites with higher priority placed on a large site with greater reduction capability.

## 3. Demand Monitoring System

### 3.1 Function

This system was established by installing Mitsubishi Electric's demand monitoring equipment at each site, and a centralized monitoring server at the Head Office, where the demand data from every site is comprehensively managed (Fig. 1).

The demand monitoring equipment and centralized monitoring server are linked via the intranet (MELIT network) and configured in a security-conscious manner.

Key functions of the components used in this system are described below.

#### (1) Demand monitoring equipment "E-Energy"

- Using the pulse signal of incoming electricity at each site, the present demand is calculated and monitored every 10 seconds.
- By setting the target demand (upper control limit of demand) and the alert level (for the purpose of pre-alert limit values corresponding to the target demand), an appropriate warning (display, e-mail, buzzer, etc.) is issued in response to the present demand trend.
- Linkage with the present demand enables automatic calculation of the forecast demand (demand forecasted for the end of the demand period) and adjustment power (electric power to be reduced/added to reach the target demand by the end of the demand period) to enable the demand to be promptly adjusted in advance.
- Real-time display of the alert status and demand load graph (Fig. 3), which visualizes the relationship between the present demand, forecast demand, target demand and alert level.
- Through linkage with Mitsubishi Electric's

web-compatible G-150AD air conditioner controller, air conditioning can be automatically controlled in response to the demand load.

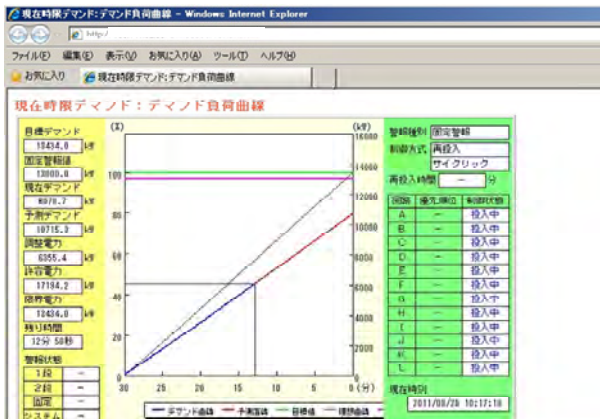

Fig. 3 Demand load curve

(2) Centralized monitoring server (Multi-demand viewer)

The centralized monitoring server for demand monitoring is integrated with the newly developed wide-area demand monitoring software.

- Data on power demand and alert status is collected every 10 seconds from E-energy equipment at all relevant sites through http communication, and is displayed in a list by the web browser (Table 1).

Table 1 Display contents on demand monitoring screen

Category	Display item	Demand time		Update interval
		30 minutes	60 minutes	
Measured values	Present demand	⊙	⊙	10 seconds
	Forecast demand	⊙	—	10 seconds
	Adjustment power	⊙		10 seconds
	Previous demand	⊙	—	10 seconds
	Remaining time	⊙	—	10 seconds
Alert status	First-stage alert	○	—	10 seconds
	Fixed alert	○	○	10 seconds
	Over-limit alert	—	○	10 seconds
Setting	Target demand	⊙		Fixed
	Alert level	⊙		Fixed
Communication error	Communication fault	○		10 seconds

⊙: At all times ○: On occurrence

- To comply with the ordinance on the restriction of electricity use, which is determined based on the electric power in one hour, the demand values for a demand period of 60 minutes are also calculated.
- The total sum of the demand data is automatically calculated for a group of multiple sites (e.g., in the service area of a certain electric power company).
- By setting the target demand (upper control limit of demand) and the alert level (pre-alert limit value for the target demand), alert e-mails are broadcast when necessary.
- The newly developed multi-demand viewer provides not only a display screen for the wide-area demand monitoring but also the capability to achieve inte-

grated control by collecting and accumulating various demand and electric energy data for each group of sites (e.g., in the service area of a certain electric power company) including: demand forecast of the day, photovoltaic power, and peak demand (forecast) of the day.

- Demand data is collected from the E-Energy equipment at each site every 30 minutes by using http communication, and is stored as daily log files.
- This demand data is used to prepare a trend analysis with automatically generated graphical representations and daily, monthly and annual reports.
- Capable of grouping multiple sites, as well as comparison and analysis on a site-by-site basis.

3.2 Features

The key features of this system are easy web-based maintenance, and various kinds of support with multiple types of alerts for preventing the demand from exceeding the limit.

(1) Web-based visual demand control

- Operation can be easily started as no special software is required by the control PC for demand monitoring; a web browser is sufficient. Since web browsing is available at any point on the intranet, it is possible to monitor the demand from a remote location. Various settings can also be easily made on the web screen.

- The web screen is automatically updated, and thus by simply keeping the web browser running, information about the demand trend (up or down trend) is always available.

(2) Alert in the case of anomaly

To quickly respond to an emergency situation and to restrict the demand, this system provides the following four types of alerts that are ready to be activated at any time in response to the monitoring system. If one of these alerts is activated, the occurrence status is displayed on the control screen, and depending on the type of alert, an appropriate e-mail is automatically sent out to the occurrence site and the concerned personnel at the Head Office.

- First-stage alert: When the forecast demand exceeds the target demand
- Fixed alert: When the present demand exceeds the fixed alert level
- Over-limit alert: When the present demand exceeds the target demand
- Communication error: When communication with an individual site fails

In actual operation, however, the telephone is also used to ensure a clear understanding of the situation and for other communication purposes, and as long as there is a margin between the total electricity use of all sites and the limit, operation rules are applied in a

flexible manner, such as “wait and see” even if an alert has been issued.

#### 4. Power-Saving Effect by Demand Control

##### 4.1 Power-saving effect

As a result of the power-saving efforts at each site and fortunately due to a cooler summer than the previous year, the target 25% reduction from the previous year was achieved for the total use of electricity throughout the summer of 2011 in both the Tokyo and Tohoku Electric Power service areas. In August, by optimizing the balance between the target values of all sites, improvements for reducing excessive burden were implemented so as to minimize the use of engine generators and normal shift operation was resumed. The power-saving measures also reduced the use of electric energy, achieving energy saving and CO<sub>2</sub> reduction equivalent to a 19% reduction of incoming electric energy compared to the same period in 2010.

The greatest achievement was brought about by thorough operational management and conversion to LEDs and other high-efficiency devices, resulting in significant power saving for lighting, air conditioning and production equipment, which accounts for 16.5% of the total power-saving achievement (after adjusting for the temperature difference from the previous year).

The second largest power saving was achieved by using the photovoltaic power generation system. As one of the power-saving measures for the summer of 2011, about 2 MW of photovoltaic systems were newly introduced. The results of photovoltaic power generation at all sites confirmed that an output of 80% or greater of the rated value can be expected during sunny days.

This time, the reduction target was very challenging, and thus each business site was forced to take drastic measures including the following modifications to the production and work shifts:

1. Rotating shift operation; shifting production to off-peak hours, holidays, or nighttime.
2. Shifting project execution timing from the summertime to the second half of the fiscal year (modification of annual business plan)
3. Shifting production to other areas (transfer of equipment, relocation of employees)

Although these measures brought significant positive effects, considering the anticipated long-term nationwide power shortage, measures 2 and 3 would be difficult to continue as they are implemented in the coming winter and after for power-saving purposes, and thus detailed coordination will be required in advance.

##### 4.2 Operational issues

- (1) Demand control with weather information taken into consideration

The analysis of daily demand data indicates that its changing pattern is quite similar to that of the daily maximum temperature (Fig. 4). The influence of the weather (amount of sunshine) is also significant, especially where the photovoltaic power generation system is also used.

Thus, an important factor for future operations will be the daily demand forecast and target control taking into consideration the weather forecast and the electricity forecast released by the electric power company.

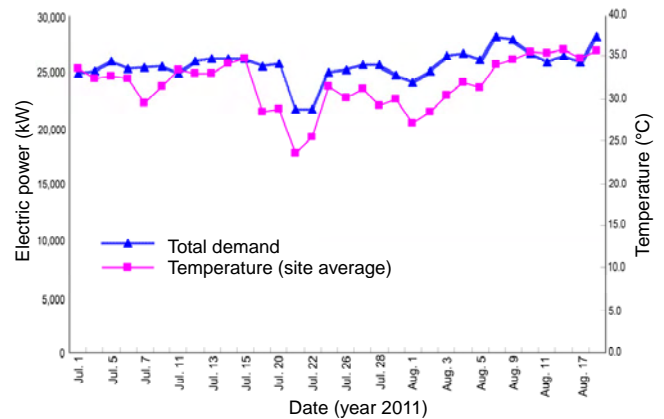

Fig. 4 Relationship between site total demand and temperature (within the service area of Tokyo Electric Power Co.)

- (2) Demand control utilizing photovoltaic power generation system

It has been confirmed that for power control in the summer, it is effective to consider the use of photovoltaic power during the daytime. In the case of an office-type business site where the largest photovoltaic system is installed in proportion to the contract demand (Fig. 5), the peak use of electricity occurred at 11 a.m. or 2 p.m. in the same way as at other sites, whereas because of the photovoltaic power generation, the peak of commercial power occurred in the evening when it was getting dark.

As shown in this example, at office-type sites where the change in electricity use is slow and day-to-day variation is small, photovoltaic power generation is expected to be effective for preventing the concentration of electricity use and saving power by shifting the time of peak power. To achieve this result, however, a certain facility size is needed in proportion to the contract demand (electricity use), and careful examination is required considering the cost, installation area, etc.

#### 5. Conclusion

In the summer of 2011, not only Mitsubishi Electric but every member of society worked hard to conserve power, resulting in a greater-than-expected contribution to power reduction in the Tokyo and Tohoku Electric Power service areas.

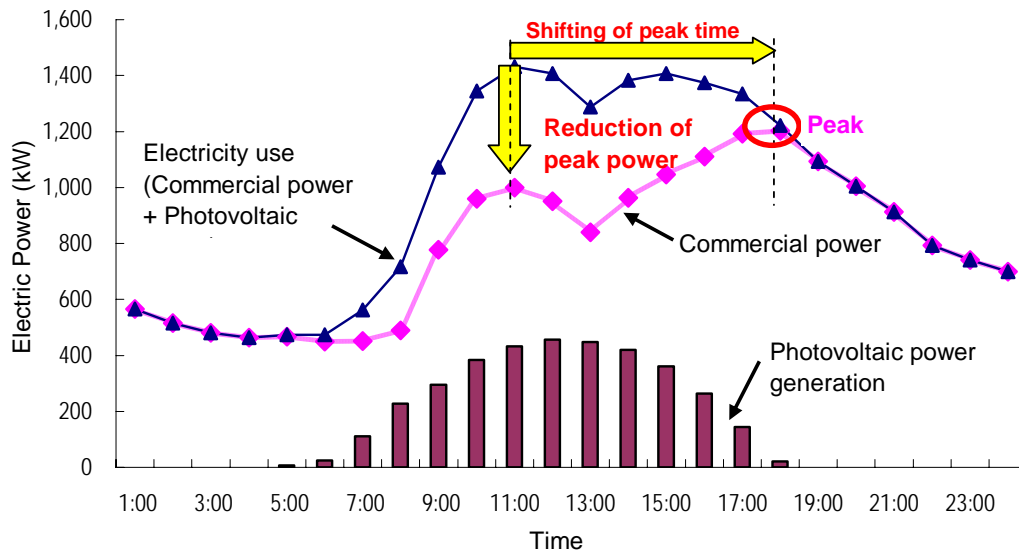

Fig. 5 Example of the contribution of photovoltaic power generation to power saving

However, the shutdown of nuclear power plants is now a nationwide issue; people are worried about power shortages not only in the Tokyo and Tohoku service areas but also in the Kansai, Kyushu and Shikoku Electric Power service areas. The power supply and demand situation is expected to remain severe in Japan for the foreseeable future. In the area where the Mitsubishi Electric Group has many large-scale production sites, power-saving measures must be urgently introduced. To cope with the risk of electric power

shortages, Mitsubishi Electric expanded the introduction of the demand monitoring system through the summer of 2012. The system has now been introduced in all high-volume users of the group, a total of 68 business sites, and a scheme to cope with a potential nationwide power shortage has been built. In addition, the know-how acquired through the experience of reducing the peak power will be used for planning and implementing the measures for saving energy (electricity use reduction) and reducing CO<sub>2</sub>.



# Factory Energy Management System Using Production Information

Authors: *Hiroyuki Makita\**, *Yuko Shida\*\** and *Naomichi Nozue\*\*\**

As a result of the Great East Japan Earthquake in March 2011, electric power supply in Japan faced a critical situation; in particular, factories that consume a large amount of electric power were seriously affected. Meanwhile, in China and other emerging countries, where the economic growth rate is high and automation of manufacturing factories is progressing, further energy saving is a key issue for economic growth and global environmental protection.

"e&eco-F@ctory," Mitsubishi Electric's factory automation (FA) energy solution, is aimed at reducing the total cost of ownership (TCO) and establishing a low-carbon society by integrating IT systems into production equipment to achieve higher productivity and energy saving in factories around the world.

## 1. Introduction

Manufacturing factories, as high-volume energy users, are required to promote further energy saving, and thus focus is placed on the Factory Energy Management System (FEMS), which manages the energy throughout the factory. The energy usage areas in the factory are largely divided into two categories: the "production system" where the actual production takes place using production equipment, and the "utility system" that functions as a part of the factory's infrastructure. Mitsubishi Electric has been promoting the "e&eco-F@ctory" FA energy solution as a subset of

FEMS that contributes to energy saving in the production system.

In the production system, productivity improvement and energy saving are closely related to each other. Improvement of the equipment utilization rate reduces unnecessary energy derived from equipment waiting time and downtime, while reducing the takt time also saves energy by decreasing the equipment operation time while keeping the same production quantity. In addition, quality (yield) improvement helps reduce unnecessary energy consumed for producing defective products.

This paper describes e&eco-F@ctory, which achieves energy saving by interrelating and managing the production information and the energy information to identify wasted energy in the production system.

## 2. FA Energy Solution "e&eco-F@ctory"

### 2.1 Total FA solution e-F@ctory

"e-F@ctory" is Mitsubishi Electric's total FA solution for visualizing production by linking the shop floor and the information system, and for reducing TCO by driving the Plan-Do-Check-Action (PDCA) cycle. The concept of "e&eco-F@ctory" was created by adding energy as an additional element to the e-F@ctory solution.

The concept of e-F@ctory is depicted in Fig. 1, where the PLC that acts as the brain to control the

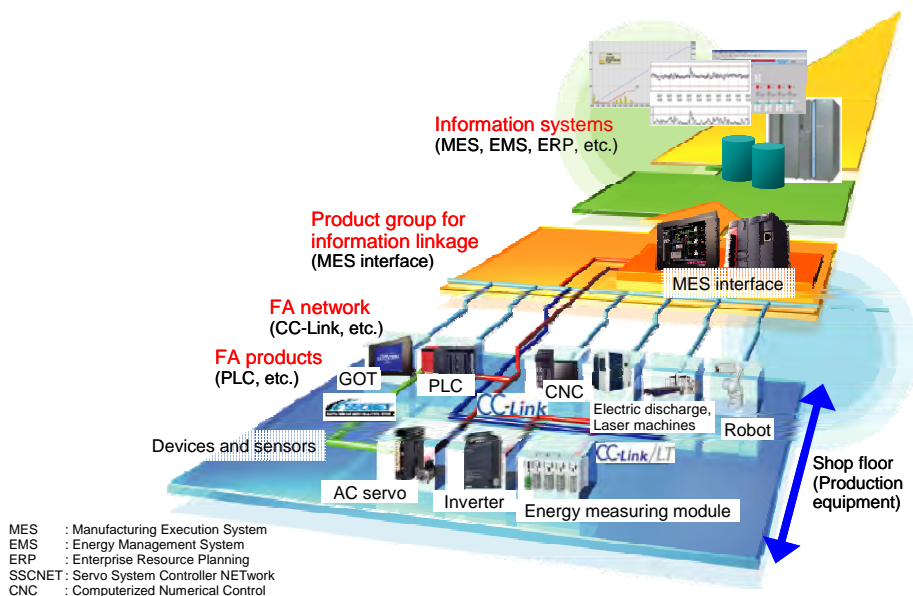

Fig. 1 Concept of Mitsubishi Electric's total factory automation solution "e-F@ctory"

operating sequence of production equipment, plus various devices, sensors and other FA products are linked together via the FA network, and through which various kinds of production information are collected.

The MES (Manufacturing Execution System) interface, one of the PLC modules for directly linking the PLC to the database, connects the production equipment directly to the information systems without any communication gateway such as a personal computer. By using the MES interface, interconnection between the shop floor and the information systems is easily established at low cost.

## 2.2 Overview of e&eco-F@ctory

To survive global competition, manufacturers must improve not only productivity but also energy efficiency in order to reduce production costs. Meanwhile, in emerging countries with high economic growth rates, automation of manufacturing processes is making rapid progress accompanied by increasing use of electric power, although sufficient power supply is not secured.

With e-F@ctory, productivity is improved by using network technology and information systems. In addition, energy efficiency and productivity are achieved at the same time by using measuring technology developed in the field of electric power receiving and distribution, which is one area of Mitsubishi Electric's power distribution control equipment business.

With e&eco-F@ctory, energy saving is achieved in four steps: "measurement," "visualization," "reduction" and "management" of energy.

An important factor of energy "measurement" is the collection of energy data in connection with production information such as quantity, not simply gathering energy use data from the shop floor. On the shop floor, the production information is stored in the PLC, and thus by providing the energy data to the PLC, it is possible to

measure the energy that is interrelated with the production conditions and the operating status of the equipment. Therefore, Mitsubishi Electric offers an energy measuring module compatible with the "MELSEC-Q Series" PLC (Fig. 2).

In the "visualization" step, the energy and production information collected in the "measurement" step and provided to the PLC are analyzed using IT technology, and then that information is "visualized" in various ways such as by part, by product, and by equipment. The MES interface supports the "visualization" step by transmitting the energy and production information to the information systems.

For the successful "reduction" of energy, it is necessary to introduce energy-saving equipment with high energy efficiency. One example is to optimize the energy consumption of the facility and equipment by using inverters, motors and other drivers with high efficiency.

In the "management" step, which pursues improvement by interrelating energy information and production information, it is important to monitor the specific consumption and energy used by the facility and equipment. Specific consumption refers to the amount of energy consumed to produce one unit of a product. The e&eco-F@ctory provides various types of management solutions to improve productivity and energy efficiency by smoothly driving the PDCA cycle for better energy efficiency.

Figure 3 is an example of visualization, where the specific consumption is displayed by process, showing that the specific consumption represented by the line graph worsens in process (5) in association with the change in product model. This example is interesting in terms of energy consumption. By overlaying the cycle time represented by the bar graph, it can be clearly seen that the cycle time increased in process (5), which disturbs the balance in the production line as a whole.

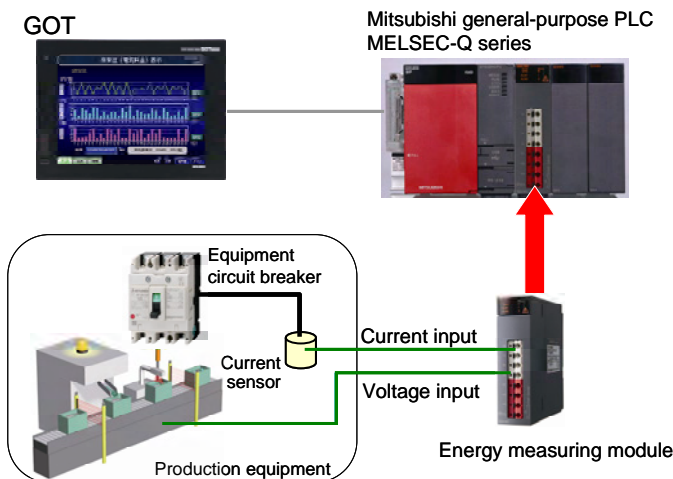

Fig. 2 Energy measurement by power measuring module

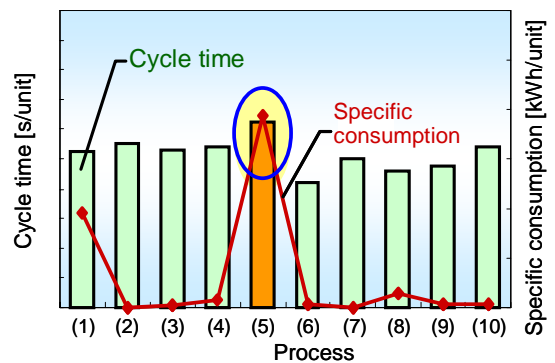

Fig. 3 Visualization using specific consumption by production process

In this case, by improving the equipment in process (5) to reduce the cycle time, the productivity of the whole production line was increased and energy consumption as a whole was reduced.

### 3. Examples of System Configuration with e&eco-F@ctory

This section describes examples of the system configuration with e&eco-F@ctory, for three of its four steps, namely: "measurement," "management" and "visualization."

#### 3.1 Visualization system for specific consumption

"EcoWebServer III" is an embedded data acquisition server that visualizes energy on a Web browser using its Web server function. The main functions of "EcoWebServer III" are as follows:

- (1) Measurement data acquisition (current, voltage, power, energy, leak current, etc.) from the CC-Link compatible measuring instruments (CC-Link is the global standard FA network "Control & Communication Link").
- (2) In addition to the measurement data from CC-Link instruments, production information is collected from the PLC and accumulated in the built-in Compact Flash<sup>1</sup> memory.
- (3) The embedded Web server function enables the status of energy use and specific consumption to be browsed via a local area network (LAN).
- (4) Without constructing a genuine EMS (energy management system) based on the server environment, a setting-only programless system can be quickly constructed (Fig. 4).

#### 3.2 Visualization system interconnected with various production information

For simultaneous achievement of the goals of

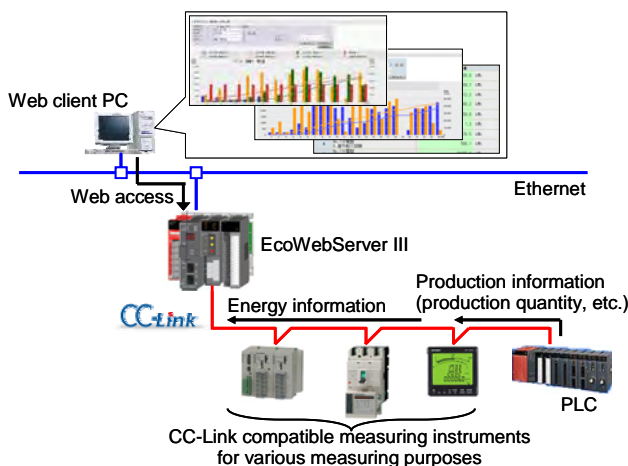

Fig. 4 Configuration of visualization system using specific consumption

<sup>1</sup> "Compact Flash" is a registered trademark of Sandisk Corp.

e&eco-F@ctory, productivity improvement and energy saving, it is necessary to identify the improvement points for production and energy use. For this purpose, it is necessary to interrelate and manage various information about the production and energy. As an example, by managing the energy consumption in response to the operating condition of each production equipment (operating, standby, or breakdown), wasted energy during standby and breakdown can be found, and the time spent waiting for parts and for set-up change resulting in standby time can be reduced. This type of management can be achieved by linking the MES that manages the production information and the EMS that manages the energy information.

Figure 5 shows an example of the system configuration using Mitsubishi FA modules. The production information as well as the energy information acquired by the energy measuring module is transmitted via the MES interface from each equipment to the MES and EMS. In addition, the energy information for the whole line is collected from the multimeters, MDU breakers, etc., in the power receiving and distribution equipment and on the panel board, and then transmitted to the EMS via the MES interface.

### 4. Examples of e&eco-F@ctory Introduced in Mitsubishi Electric Factories

As an example of the "measurement," "management" and "visualization" steps described in Section 3, this section presents the breaker production line at the Fukuyama Works, Mitsubishi Electric's production base for electric power distribution control equipment.

At the Fukuyama Works, management of specific consumption has long been performed for each production line. Through small group activities, it was possible to identify the factors that may deteriorate the specific consumption and determine their countermeasures. However, since the specific consumption management had been performed on a line-by-line basis, detailed information about the production and energy were separate from each other, and so significant time and manpower were required to analyze the deterioration factors of the specific consumption. It was also difficult to pinpoint the bottleneck equipment in the line. Consequently, as shown in Fig. 6, the specific consumption management system was introduced in each equipment on the line. As a result, the bottleneck process was immediately identified, and by examining the production and quality information stored in the PLCs, effective factor analysis was performed and countermeasures against the deteriorated specific consumption were implemented.

The features of this system are as follows:

- (1) Energy measurement for each production equipment

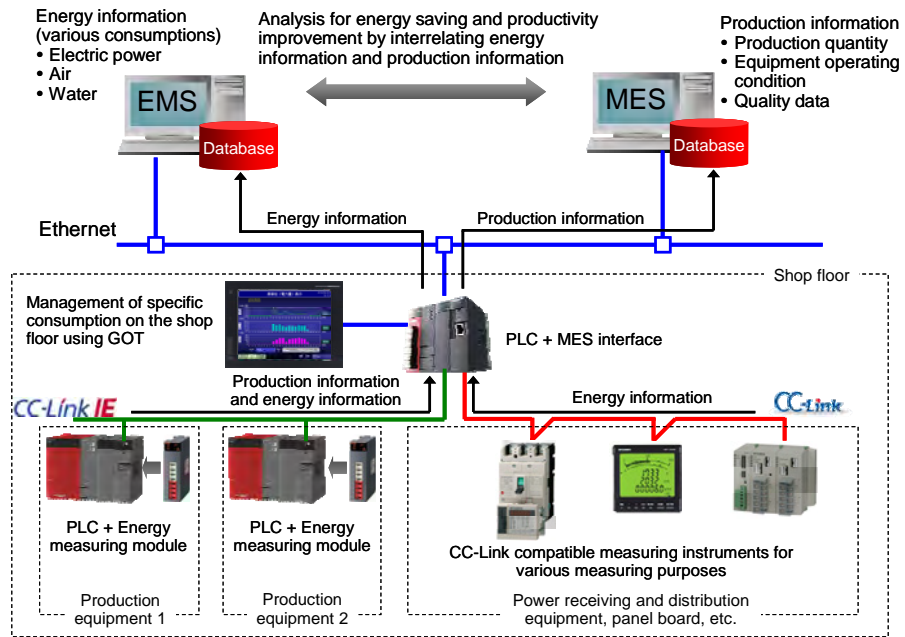

Fig. 5 Visualization system using production and energy information

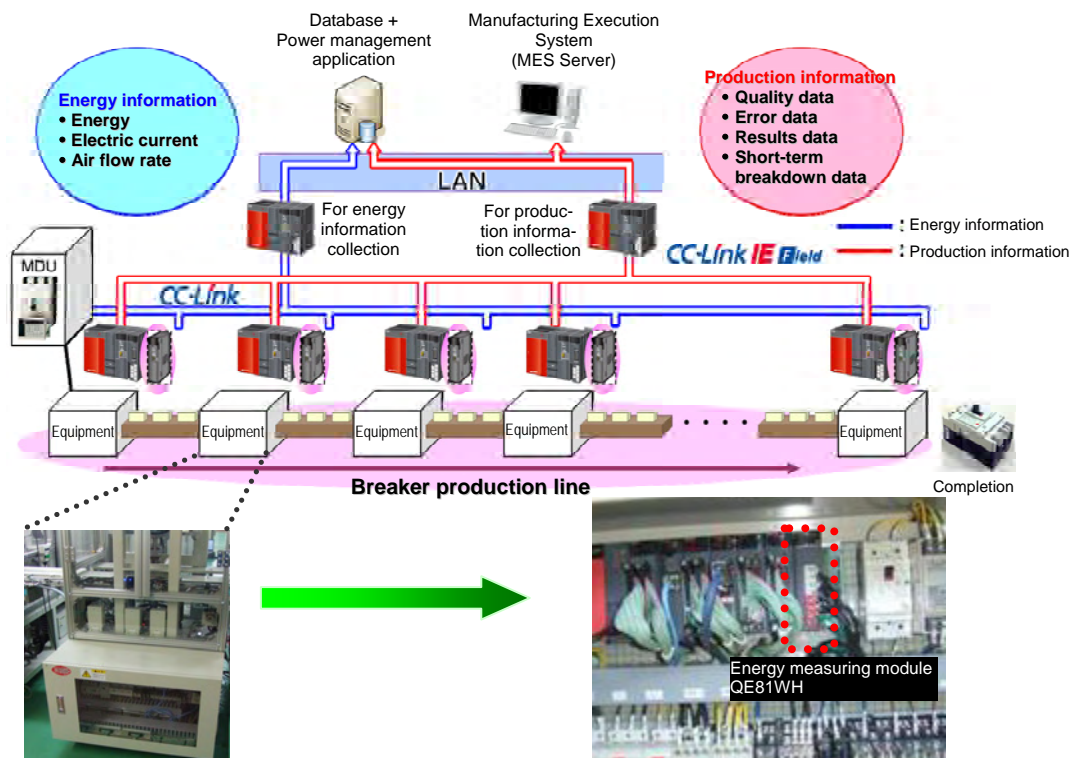

Fig. 6 e&eco-F@ctory system and control panel

The energy measuring module QE81WH, which is ideal for measuring equipment (small control panel), is installed in each production equipment. The energy is measured equipment-by-equipment and monitored by an upper-level database server.

(2) Input of production and quality information

The information stored in the PLC of each equipment, namely: production information (production quantity) and quality information (frequency, duration, type of

error, etc., of short-term breakdown), is provided to the upper-level database server via the MES interface module. This enables detailed management of the specific consumption and effective factor analysis.

(3) Visualization at upper-level database server

① Specific consumption for production equipment

On the conventional display screen for the specific consumption management, the specific consumption was calculated from the energy and production quantity

for the whole line and their trends were displayed in chronological order. In this new system, the specific consumption per day per equipment is displayed for all equipment on one screen (Fig. 7).

② Analysis of specific consumption

On the specific consumption analysis screen, detailed graphs of the specific consumption, and the frequency and duration of short-term breakdown are displayed in chronological order (Fig. 8). By displaying this information on one screen, it is possible to grasp the correlation between the deterioration of specific consumption and the short-term breakdown.

③ Analysis of short-term breakdown

The short-term breakdown analysis screen displays the breakdown count per day per equipment and the details (error description, occurrence time, time for equipment restoration, etc.). This information enables effective analysis and implementation of corrective measures for improvement of the equipment (Fig. 9).



Fig. 7 Specific consumption for production equipment

5. Conclusion

This paper described application examples of “e&eco-F@ctory,” the FA energy solution, which focuses on reducing energy in production systems, one of the FEMS’s target areas for reducing the total energy in factories. While this system has been introduced in many factories around the world, the examples presented here were implemented at the Nagoya Works and Fukuyama Works, Mitsubishi Electric’s model factories.

We will roll out this solution globally, centering on Asian countries, especially in China, by converting Mitsubishi Electric’s own factories located in Dalian and Changshu to model factories.

To enhance this solution, we will examine the strategy for general energy reduction throughout the factory and also focus on the “utility system,” as well as restriction of peak power including energy generation and energy storage.

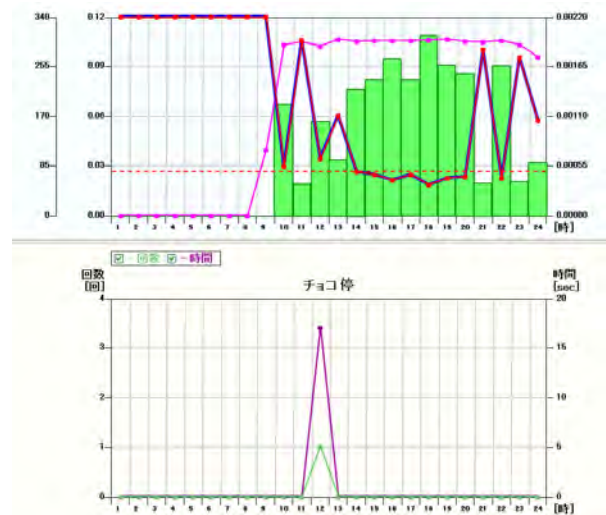

Fig. 8 Analysis of specific consumption

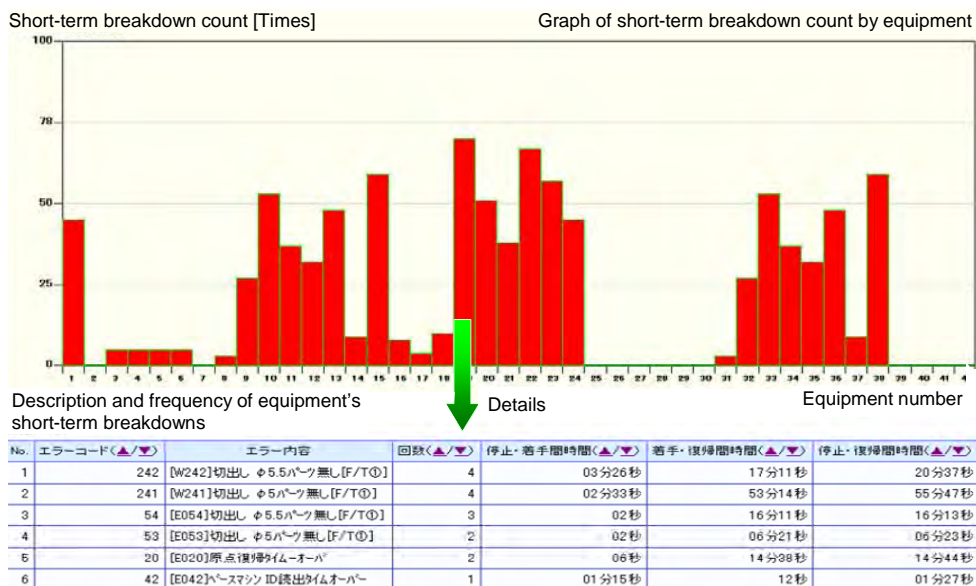

Fig. 9 Details of short-term breakdown

# *Solution of IT System for Management of Chemical Substances Contained in Products*

Author: *Hiroko Higuma\**

## 1. Introduction

European regulations on the chemical substances contained in products have been strengthened, starting with the enforcement of the Restriction of Hazardous Substances (RoHS) Directive in July 2006, which restricts the use of six specified hazardous substances in electrical and electronic equipment. In June 2007, the *Registration, Evaluation, Authorisation and Restriction of Chemicals* (REACH) entered into force, and almost all products (referred to as Articles under REACH) are subject to this law. In addition, in July 2011, the RoHS directive was revised and strengthened.

In Japan, to comply with the REACH regulations, companies and organizations in the chemical, electric and electronic, and automotive industries voluntarily established the *Joint Article Management Promotion Consortium* (JAMP) in September 2006. JAMP developed and provides the format for describing information about chemical substances contained in products, and established the JAMP Global Portal (JAMP-GP) to build an electronic data interchange (EDI) network. In addition, the latest version of the JAMP information format provides enhanced functionality with additional information relevant to the revised RoHS.

Utilizing JAMP's system, Mitsubishi Electric independently developed the "IT system for management of chemical substances contained in products," which has been adopted by the entire group.

This paper describes the regulations covered by the Mitsubishi Electric system, as well as an overview of the system and future prospects.

## 2. Regulations Covered by Mitsubishi Electric System

(1) Article 33 of *REACH regulation*, Obligation to provide information

About twice a year, new substances of very high concern (SVHC) are added to the candidate list for authorization. Although there are now 84 substances on the list, the number may ultimately rise to 1,500. If a product contains any substance on the candidate list for authorization above 0.1% per product weight, information about the substance must be provided immediately

to the customer companies and within 45 days to the consumers.

(2) Article 7 (2) of *REACH*, Obligation of notification

If products placed on the European market (imported or manufactured) are subject to the obligation to provide information, i.e., products that contain an SVHC on the candidate list for authorization above 0.1% per product weight, and the total mass of the substance exceeds 1 tonne per year, notification must be made to the European Chemical Agency within six months after the inclusion of the substance in the Candidate List.

(3) Regulations on restricted substances (*REACH*, *RoHS*, and *POPs* (*Persistent Organic Pollutants*))

While *RoHS* restricts the use of six substances, certain applications are exempted from the restriction; however, these exemptions have expiration dates. *REACH* and *POPs* regulations also specify the substances that should be restricted or abolished, with some exemptions.

## 3. Details of Mitsubishi Electric System

The system structure built within Mitsubishi Electric is shown in Fig. 1. Mitsubishi Electric' system is physically composed of an application server and a tool {1}, described below. As denoted by {1} through {4} in the figure, the system has four functions: {1} to automatically collect, provide and revise the information; {2} to calculate the chemical substance mass to determine the obligation of notification; {3} to automatically prepare response documents for consumers and customers; and {4} to search and browse information on chemical substances contained in procured items and products. Each function is described below.

(1) Automatic collection, provision and revision of information

By connecting to the JAMP-GP, this system collects and provides through the network (JAMP IT) electronic information described in the JAMP information format. This information is identified only by the model name of the part or product and the company ID of the issuer. Revised information that is uploaded to the JAMP-IT is simultaneously sent out to each customer ID that has a history of information provision.

With this communication method, each customer can automatically receive the revised information. The model name given on the JAMP information format is the model name of the issuing company (supplier), not the customer's model name used when the product is supplied to the customer; hence the supplier's model name is unknown to the customer. Therefore, JAMP-IT provides a mechanism for obtaining the supplier's model name by the customer's model name known to the customer. First, Mitsubishi Electric's AS requests information by the customer's model name. After that, the supplier responds with their own model name. In Mitsubishi Electric's system, a search is automatically initiated at the same time that the supplier's model name is provided. In addition, information to be uploaded to JAMP IT is checked prior to uploading to

avoid duplicate work by the recipient due to incorrectly entered information. Meanwhile, for companies that do not use JAMP IT (Supplier B in Fig. 1), as denoted by {1} in Fig. 1, Mitsubishi Electric provides these suppliers with a tool that interrelates the model names provided by Mitsubishi Electric and the supplier, checking the information to be entered.

(2) Calculation of total mass of chemical substances

In one year, Mitsubishi Electric Corporation ships more than 10,000 kinds of items including the products themselves, packaging materials and included items. We have established a system to calculate the chemical substance mass and to easily determine whether or not notification is required.

Figure 2 shows the process for tabulating the chemical substance mass contained in products per

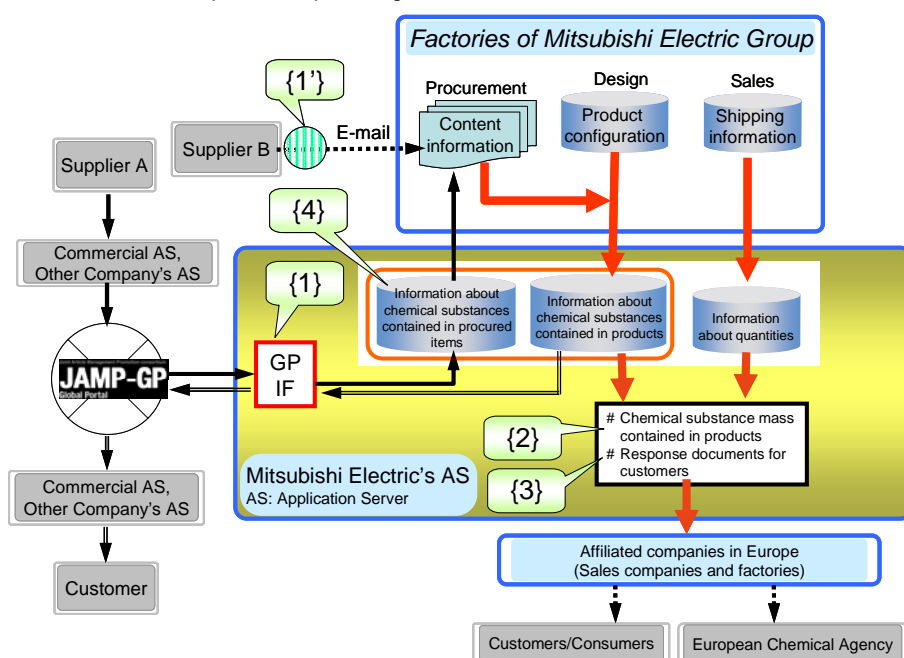

Fig. 1 Mitsubishi Electric's IT system in-house for management of chemical substances contained in products

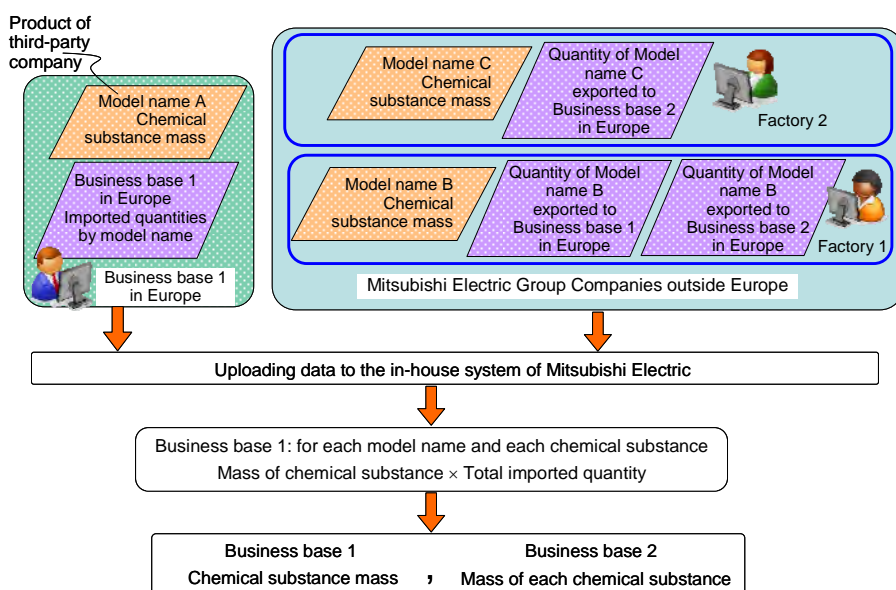

Fig. 2 Process for tabulating chemical substance mass contained in products per company in Europe

company in Europe. In the figure, "Factory 1" located outside Europe exports a "Model name B" product to "Business base 1," and "Business base 1" imports a "Model name A" product for itself; that is, "Business base 1" imports "Model name A" and "Model name B" products. In this system, the total mass of a chemical substance of concern is calculated for all the products either exported from the factory outside Europe or imported by the business base in Europe for itself. Figure 3 shows the process for tabulating the chemical substance mass contained in products per substance. Both the "Model name A" and "Model name B" products contain a chemical substance with CAS No. 117-81-7, which is an SVHC on the candidate list for authorization. In this system, for each importer, the chemical mass of each model is multiplied by the quantity, and then summed up for each substance and year, and thus the chemical substance mass per importer per year is determined. With regard to the quantity data, the results of the previous year and estimates for the current year are registered. Mitsubishi Electric has an internal rule requiring notification if even an estimated chemical substance mass exceeds 1 tonne per year.

(3) Automatic preparation of response documents for consumers and customers

Our sales companies in Europe sometimes receive a customer request to simultaneously provide information about substances contained in multiple products from the past. Even if this information is registered in the system, it is time-consuming to prepare a response by searching for the data on each model name one-by-one. Therefore, we have established a system for preparing a set of requested information about certain products all at once, by simply defining a query

using only the name of the business base in Europe, year of import into Europe and the common product name; and then clicking a button for document preparation. The response document includes a list of model names, a composition table, and a letter declaring the presence or absence of an SVHC on the candidate list for authorization. This system has made it possible for each business base in Europe to quickly respond to customers without waiting for information from the manufacturing base.

(4) Searching and browsing of information about chemical substances contained in products

While the above functions (1) through (3) are related to the REACH regulation, there are additional regulations in Europe such as the RoHS directive and POPs regulation. The latest JAMP information format has been modified with enhanced functionality to easily manage the six RoHS directive substances, i.e., verification of their presence, and control of the usage status and expiration date of exemption items. Mitsubishi Electric's system has also been revised to be compatible with the latest JAMP format, with enhanced searching and browsing capabilities to provide information about compliance with the regulation.

#### 4. Future Prospects

To keep this system continuously operating, the JAMP information format should be widely distributed and commonly used in the supply chain. While the system is fairly well spread in Japan and Asia, European and American companies rarely use this format and, on their behalf, Japanese trading companies perform the conversion to the JAMP format. In Europe, BOMcheck.net is relatively widespread and a conver-

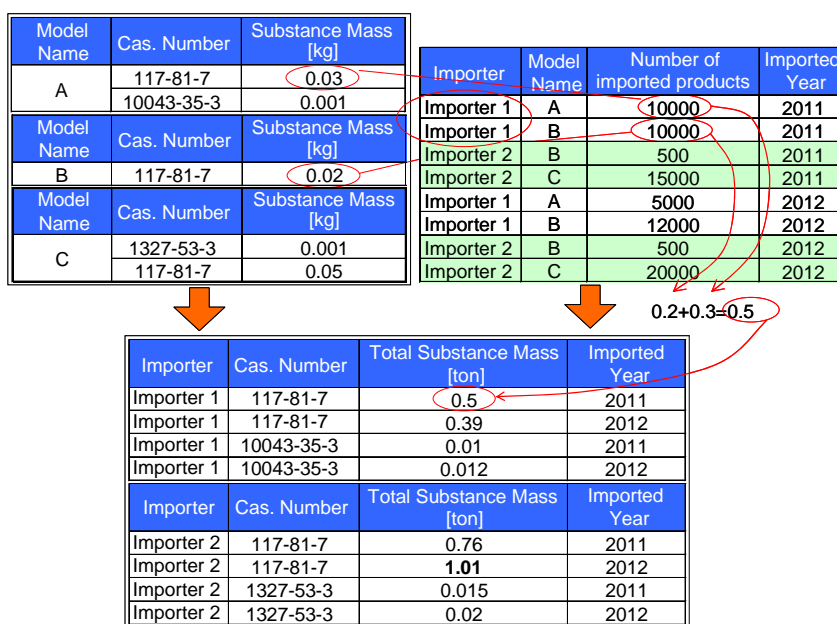

Fig. 3 Process for tabulating chemical substance mass contained in products per substance



sion service from BOMcheck.net to JAMP format recently became available. For the smooth exchange of information about chemical substances contained in products, it is important to establish mutual coordination and cooperation between BOMcheck.net and JAMP-IT, rather than focusing on one system.

In March this year, the IEC 62474 standard "Material Declaration for Products of and for the Electrotechnical Industry" entered into force. This standard focuses on the control of *RoHS* and other restricted substances, and an electronic data exchange format has been defined in this standard. We will strive for standardization, while harmonizing with the JAMP activities.

# Advanced Recycling Technologies for Plastics and Rare Earth Magnets Used in Home Appliances

Authors: Yasushi Uehara\*, Muneaki Mukuda\* and Takeshi Tsukasaki\*\*

Mitsubishi Electric has developed advanced recycling technologies for the plastics recovered from used home appliances, namely, separation of plastic types, processing for RoHS compliance, and product applications. These technologies help to recover a large amount of high-quality recycled plastics and the expansion of their application to products. By combining them with the technology to recover rare earth magnets from air conditioner compressors, we will promote self-closed loop recycling of electric home appliances.

## 1. Introduction

Mitsubishi Electric has been aiming at the establishment of a recycling-based society, and founded Hyper Cycle Systems Corporation (HCS) in 1999 prior to the enforcement of the *Law for Recycling of Specified Kinds of Home Appliances (Electric Home Appliance Recycling Law)*. HCS is the industry's first home appliance recycle factory, where shredded mixed plastics are produced by the mechanical shredding and separation process. In 2010, the operation of Green Cycle Systems Corporation (GCS) was commenced, where the shredded mixed plastics from HCS, which include many types of plastic, are separated to a high degree to produce recycled raw materials. In the plastic separation line built at GCS, gravity, electrostatic, and other separation technologies are employed. The shredded mixed plastics are separated and recycled into single plastic type materials, which are used as recycled plastic materials for some of Mitsubishi Electric products. In addition, rare earth magnets are recovered from room air conditioner compressors.

This paper presents recent activities related to these technologies.

## 2. Toward Expansion of Self-closed Loop Plastic Recycling

In order to increase the amount of plastic materials separated and recovered from shredded mixed plastics, and then used for the products, it is required to separate and recover a large amount of plastics by improving the efficiency of separation processes, to improve their quality, and to expand the application range of the

recycled materials.

Therefore, to establish a large-scale circulation in the product market, it is important to develop:

(1) Technology to accurately identify the plastic types contained in the shredded plastic flakes

Improvement of separation efficiency by controlling the component ratio prior to the electrostatic separation; and the purity control of separated plastic flakes

(2) Technology for the large-scale separation and elimination of environmentally restricted substances

To achieve RoHS compliance by removing plastic flakes that contain bromine

(3) Product application technologies for recycled plastics

A wider range of available color tones equivalent to new material; and the concealment of unavoidable residual contaminants, etc.

In addition to improving the purity of plastics and ensuring RoHS compliant high quality, it is also important to ensure high-level visual design in the use of recycled products.

## 3. Development of Advanced Plastic Recycling Technologies

### 3.1 Plastic separation technology

Shredded mixed plastic contains polypropylene (PP), polystyrene (PS) and acrylonitrile butadiene styrene (ABS) plastics and many other types of plastic materials. We examined the technologies for the accurate and automatic identification of plastic types in these mixed plastics. The plastic identification technology using a near-infrared light has been proved to be effective for white-colored plastics, but difficult for colored plastics. Shredded mixed plastics from electric home appliances include relatively large quantity of colored plastics, which thus need to be identified. We considered a plastic identification method using a reflection spectrum of mid-infrared light, which is able to identify colored plastics and the equipment configuration is relatively simple.

When an optical reflection is used for identification, a signal from the specimen (reflected light) needs to be fully captured. Since plastic flakes contained in

the shredded mixed plastics vary in the thickness, the position of reflection point fluctuates, and thus it is difficult to obtain an effective signal in a stable manner. To overcome this instability factor, as shown in Fig. 1, the setting angle of the incident light is reduced, and thus a plastic thickness margin of 5 mm has been achieved. As a result, sufficient signal intensity can be obtained from moving plastic flakes without adjusting the optical system depending on the specimen thickness. In addition, since a reflection from the specimen stage generated abnormal scattering peaks in the spectrum for identification, a reflection-reduced specimen stage has been employed to obtain a clear spectrum. Figure 2 shows examples of infrared (IR) spectra obtained using the reflection-reduced specimen stage.

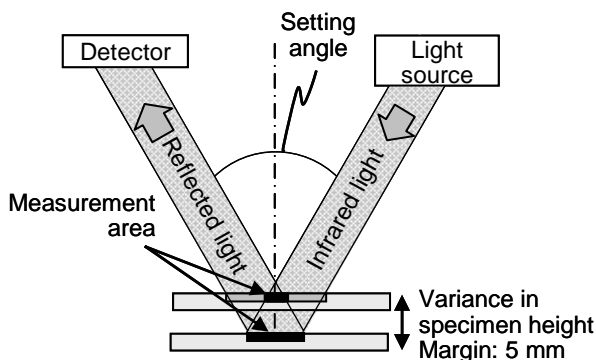

Fig. 1 Specimen-height dependence of positions of IR irradiation and measurement areas

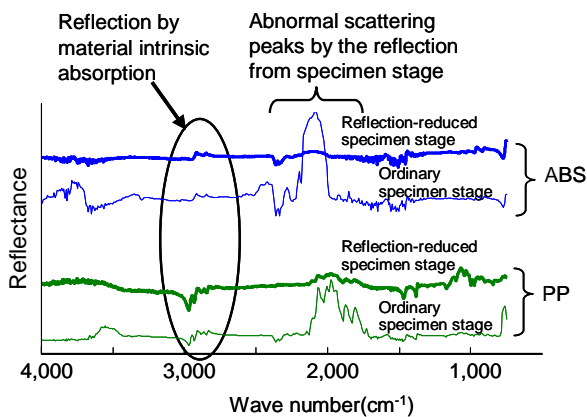

Fig. 2 Typical measured IR spectra of plastic flakes

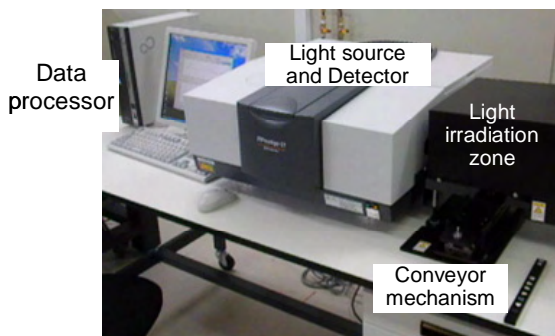

Fig. 3 Prototype plastic identification equipment using IR spectroscopy

With these findings, prototype equipment was built for the principle verification purpose (Fig. 3). This equipment consists of a light source, a detector, a data processor and a light irradiation zone based on the IR reflectance spectroscopy, and a simple conveyor mechanism. Using this prototype equipment, the identification performance was verified for the PP, PS and ABS plastic flakes separated and recovered at the recycle plant, resulting in an identification accuracy of 80–85% at a speed of about 1 sec/piece.

### 3.2 Technology development for large-scale elimination of bromine-containing plastics

In order to use the recycled plastics for electric home appliances, they must comply with the RoHS directive. A detailed examination of the ingredients in our recycled plastics has been shown that only a residual of bromine-based flame retardant in the flakes might overpass the regulation limit of the RoHS directive. In the case of three main plastics used for home appliances, namely, PP, PS and ABS plastics, the RoHS regulation threshold of 300 ppm for Br concentration can be cleared by eliminating plastic flakes that contain 1 wt% or more of bromine (Br). To identify Br-containing plastics, for all shredded plastic flakes being conveyed, the Br content is measured by means of the difference in the X-ray transmittance due to the X-ray absorption effect of Br. Plastic flakes identified to be eliminated are selectively removed using an air blower gun. When shredded plastic flakes are being processed in a large scale, as the conveyance density increases, “co-elimination” begins to occur, where a Br plastic flake is removed by the air blower gun together with nearby flakes not necessary to be removed. This phenomenon is thought to occur because the air blow is not focusing on the Br plastic flake to be removed, but spread around it (mainly behind the moving Br plastic flake). The air blow duration depends on the amount of air inside the piping of air blow gun, and thus the control accuracy of the air blow can be improved by reducing the inner volume of the piping. Consequently, by unifying the solenoid valve and air nozzle, the amount of inner air of the air blow for plastic removal is reduced to nearly zero. We have developed large-scale separation and elimination equipment equipped with this new air blow gun (Fig. 4). Figure 5 shows the elimination result with this equipment and using model samples. As can be seen from Fig. 5, Br plastic flakes (black) are successfully separated.

The plastic flakes, after the gravity and electrostatic separations at GCS, are processed for identifying and eliminating Br containing plastics, and the processed PP, PS and ABS plastic flakes have been confirmed to be RoHS compliant.



Fig. 4 Large-scale eliminating equipment for plastic flakes containing bromine

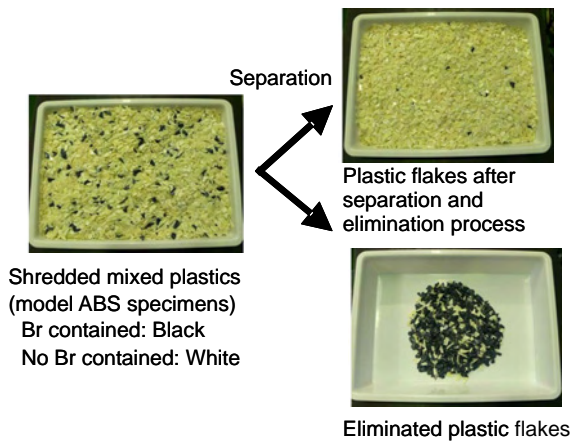

Fig. 5 Plastic flakes (model samples) after bromine elimination process

### 3.3 Product application technologies for recycled plastics

With recycled plastics derived from shredded mixed plastic scrap, it is difficult to ensure the visual appearance design due to remaining color from previous product, small amount of residual contaminant, etc. In addition to a high purity and quality as raw materials, product application technologies are required to ensure the visual appearance for the applicability to products.

#### (1) Contaminants concealment molding

If a small amount of contaminant in the recycled plastics appears on the mold surface, visual appearance is degraded. To mitigate the influence of contaminant, we examined a contaminants concealment molding technique, which uses a grained mold with minute roughness formed on the surface and imprints the pattern on the molded product with asperities. Figure 6 shows the experimental results. The grained molding gives better concealment of contaminants compared with the smooth mold surface. In the case of constant mold temperature control, the level of concealment

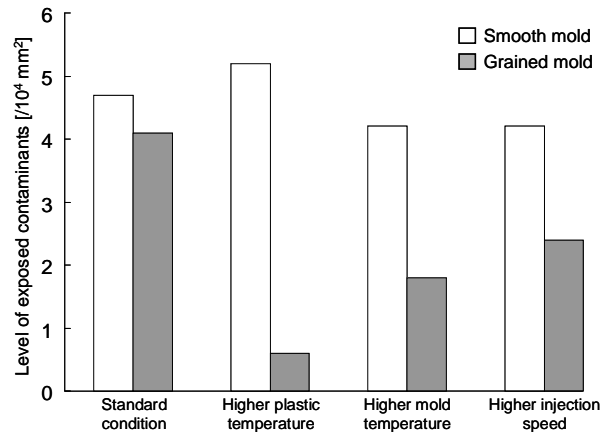

Fig. 6 Concealment levels vs. molding conditions (Constant mold temperature control)

varies from high to low in the order of higher plastic temperature, higher mold temperature, and higher injection speed. However, a higher mold temperature may cause a risk of mold deformation, and caution needs to be exercised. In the case of mold temperature control with short time heating and cooling, where the mold is heated and cooled during a molding process cycle, the level of concealment is in the order from high to low: higher plastic temperature, higher injection speed, and higher mold temperature; and the combination of higher plastic temperature and higher injection speed was found to give an even higher level of contaminants concealment.

#### (2) Color sorting technology

Conventional recycled plastics have often been used mainly for gray- or black-colored applications, because recycled plastics contain colored plastic materials, and thus dark color applications are advantageous for concealing an appearance of contaminants.

If plastic materials can be sorted by the graduation of color and separated into whitish and blackish groups, the range of adjustable color tones will be significantly widened. In order to accurately separate whitish plastics by using the color sorting equipment, we examined the optimization of various sorting conditions such as conveyed amount by using Taguchi method. Table 1 lists the brightness before and after the color sorting process, and Fig. 7 shows an example of plastic flakes before and after the color sorting. For ABS plastics, the target brightness of 80% was achieved. For PS and PP

Table 1 Brightness before and after color sorting process

Plastic type	Before sorting	After sorting (Whitish)
PP plastics	53%	77%
PS plastics	49%	77%
ABS plastics	54%	80%



Fig. 7 Plastic flakes after color sorting process

plastics, although brightness of 80% was not achieved, we have a good prospect to achieve 80% by adding white coloring material such as titanium oxide.

**4. Spread of Developed Technologies: Recycle Flow**

Figure 8 is a flow chart of the plastic recycling to which developed technologies are applied.

The technologies for plastics type identification will be applied to the automatic measurement of component ratio and purity of plastics before and after the separation processes. A further improved component ratio test for shredded mixed plastics may be applicable to the optimization of the process conditions for electrostatic separation. For the application to the purity control of separated plastics, higher identification accuracy is required to ensure the quality, and thus further improvement of accuracy is required.

By applying the large-scale elimination of Br-containing plastics (separation by using X-ray), RoHS compliance can be achieved for the three main plastics used for home appliances. We are now verifying the process stability during further large-scale op-

eration in order to introduce the full-scale operation on a commercial basis.

The product application technologies for recycled plastics enable their use in wide range of parts including visual design components. While there is a good prospect for the application through the establishment of elemental technologies, it is still necessary to examine practical application to the actual parts of complex shapes.

**5. Evaluation of Environmental Impact of Recycled Plastics**

The environmental assessment was applied to the self-closed loop recycling technologies. The evaluation was performed on the processes of: recovering shredded mixed plastics from waste electric home appliances, gravity separation, contaminant removal, electrostatic separation, elimination of Br-containing plastics, and re-pelletizing at an external entrusted company to produce recycled plastic pellets. In this evaluation, we have used the data of actual processed quantity, time of processing, material balance, and amount of energy, which were collected from each process of the recycling systems at HCS and GCS. The estimation was performed based on "the product basket method," where the product in shortage at each recycling process is supplied by new production and the output products are assumed to be equivalent. The evaluation showed that the amount of greenhouse gas emission in the case of self-closed loop recycling is expected to be reduced by about 76% from that of the landfill, and by about 83% from that of the chemical recycling.

**6. Rare Earth Magnet Recycling Technology**

Compressors removed from wasted room air con-

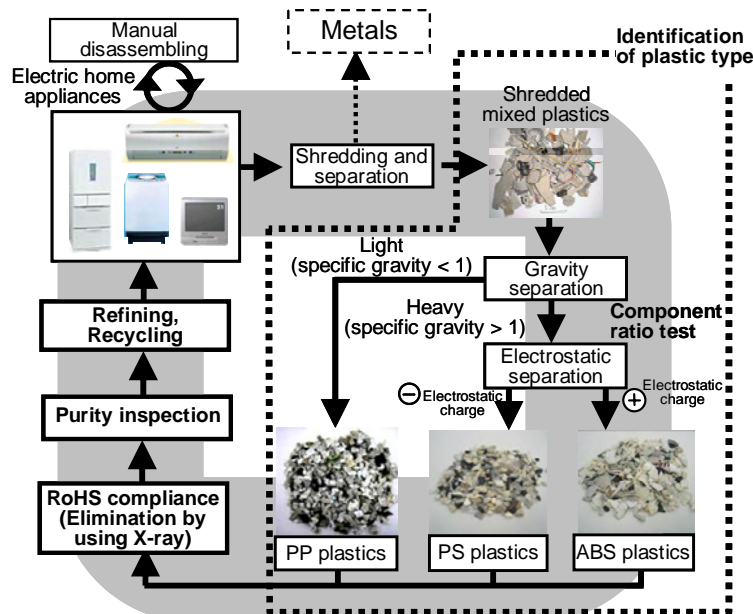

Fig. 8 Flow chart of large scale and high purity plastic recycling

ditioners have been disassembled into copper and iron materials at GCS using the compressor disassembling equipment. This time, automatic disassembling equipment as shown in Fig. 9 has been developed for the recovery of rare earth magnets regardless of the rotor shape. This equipment consists of three subsystems for the extraction of rotor from half disassembled compressor, normal temperature demagnetization in the magnetic field on resonance damping, and separation of the balancer. They are integrated into one unit and automated with a transfer system between the processes. This equipment is connected with the existing compressor disassembling line, and is able to effectively recover rare earth magnets with a takt time of 30 seconds.

It is planned that recovered rare earth magnets are supplied to magnet manufactures and reused as new magnets in Mitsubishi Electric products.

### 7. Conclusion

In order to further increase the amount of shredded mixed plastics to be used for the products, we have developed the technologies for plastic type identification, large-scale elimination of environmentally restricted substance, and product application, and achieved the following results:

- (1) By means of the plastic type identification using infrared spectroscopy, we have a good prospect of achieving an identification accuracy of 80% for moving shredded plastic flakes. We are planning to introduce the technology to practical applications by improving the identification accuracy and achieving automatic operation.
- (2) We have developed large-scale separation and

elimination equipment, which uses X-ray and is capable of high-speed separation and elimination of Br-containing plastic flakes mixed in the plastic scrap. It has been confirmed in the large-scale processing test that all of recycled PP, PS and ABS plastics can be RoHS compliant.

- (3) Color sorting and contaminants concealment technologies have been developed. These elemental technologies, related to color toning and molding, will be applied to recycled plastics for visual design parts, and hence, the significant expansion of the applicable range of components will occur.

In addition, for the purposes of establishing domestic circulation of the rare earth:

We have developed automatic disassembling equipment to recover rare earth magnets in a short time from room air conditioner compressors.

It should be noted that the development of plastic recycling technologies presented in this paper is the outcome of the FY2009 commissioned project sponsored by the Ministry of Economy, Trade and Industry "Development of Advanced Plastics Separation Technology"; and the development of rare earth magnet recycling equipment was supported by the "Project for the introduction of industrial equipment for the utilization of rare earth" sponsored by the Ministry of Economy, Trade and Industry.

### Reference

- (1) Mitsubishi Electric Corporation: FY2009 Commissioned Research & Development sponsored by the Ministry of Economy, Trade and Industry (Development of Advanced Plastics Separation Technology) Project report (in Japanese)

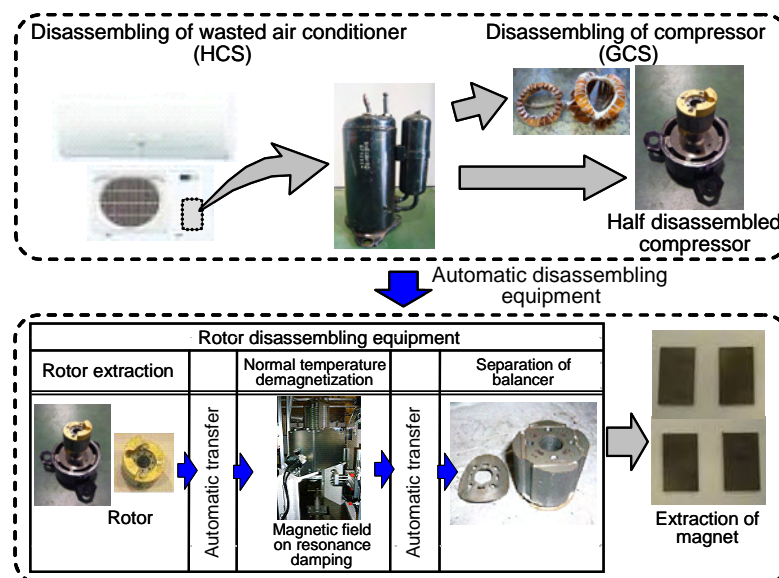

Fig. 9 Recycling process for rare earth magnets in wasted compressors of air conditioners

