

VOL. 99/SEP. 2002

MITSUBISHI ELECTRIC **ADVANCE**

Elevators & Escalators Edition



Elevators & Escalators Edition

CONTENTS

TECHNICAL REPORTS

Overview	1
<i>by Yukio Kusuoka</i>	
The "ELENESSA" Machine Room-Less Elevator for Overseas Markets	2
<i>by Hideaki Kodera and Takehiko Kubota</i>	
New Traction Machine for Machine Room-Less Elevators	5
<i>by Kenji Inoue and Nobuaki Miyake</i>	
"Universal Design" in ELENESSA (Machine Room-Less) Elevators	9
<i>by Kazuko Matsuda and Masayuki Miyawaki</i>	
The New ΣAI-2200 Elevator Group-Control System	12
<i>by Masaaki Amano and Toshio Masuda</i>	
The Overseas Version of the MIC & Remote Maintenance System	16
<i>by Yasuhiko Tanabe</i>	

R&D PROGRESS REPORT

The World's Fastest Elevators	19
<i>by Satoru Kato and Jun-ichi Higaki</i>	

TECHNICAL HIGHLIGHTS

Escalators with High-Speed Inclined Sections	22
<i>by Manabu Ogura and Yasumasa Haruta</i>	
Diagnostic & Support Equipment for the Insulation of Traction-Machine Motors	23
<i>by Teruo Konno and Naoya Yamada</i>	

NEW TECHNOLOGIES

MELART-II; New Full-Color Paint Finish	27
New Home Elevators	27

Cover Story

This cover shows: (1) The car for our new machine room-less elevator ELENESSA model together with the traction machine it uses (the slimmest in the industry). This elevator does away with the machine room and thus allows for increased freedom in architectural layouts. (2) MELART-II doors with full-color painted finish, allowing for highly detailed depiction of any pattern you may desire. (3) The hall operating panel for the new ΣAI-2200 group control system that assigns cars in response to car calls.

Editor-in-Chief

Kiyoshi Ide

Editorial Advisors

Futoshi Takahashi
Koji Kuwahara
Keizo Hama
Katsuto Nakajima
Masao Hataya
Hiroshi Muramatsu
Yoshimasa Ishino
Fuminobu Hidani
Yukio Kurohata
Hiroshi Yamaki
Kiyohide Tsutsumi
Osamu Matsumoto
Hiromasa Nakagawa

Vol. 99 Feature Articles Editor

Hiroshi Muramatsu

Editorial Inquiries

Keizo Hama
Corporate Total Productivity Management
& Environmental Programs
Mitsubishi Electric Corporation
2-2-3 Marunouchi
Chiyoda-ku, Tokyo 100-8310, Japan
Fax 03-3218-2465

Product Inquiries

Osamu Kanamori
Manufacturing Planning Department
Inazawa Works
Mitsubishi Electric Corporation
1 Hishimachi
Inazawa-shi, Aichi 492-8682, Japan
Fax 0587-24-5760

Mitsubishi Electric Advance is published on line quarterly (in March, June, September, and December) by Mitsubishi Electric Corporation.
Copyright © 2002 by Mitsubishi Electric Corporation; all rights reserved.
Printed in Japan.

Overview

New Elevators and Escalators



*by Yukio Kusuoka**

Here in Japan, there are very vocal concerns regarding the hollowing out of industry or the loss of technological precedence. In the world of elevators, it is a fact that we have allowed the Europeans to get ahead of us in machine room-less elevators and that the Chinese and Korean manufacturers whose selling point is their cheap prices are catching up on us. But, stop for just a moment. Has Japan's ability to produce really become so enfeebled?

Japanese merchandise, which right after the war was a synonym for cheap, poor quality goods, is now recognized for its top quality globally. Japanese manufacturers have found their driving force in an unswerving focus on cultivating manufacturing technologies and skills with the aim of producing high quality products; Japan's superiority in this regard remains unshaken. Notably, for elevators, which serve as a vertical transit system, reliability and safety are of critical importance.

This concept of quality as number one is a constant throughout Mitsubishi elevators' history, and our products have gained an excellent reputation from customers in the major markets. With reliability and safety as the basis, we are also giving consideration to comfort, efficiency, as well as people-friendly designs and protection for our earth's environment. Always producing products that anticipate the demands of the times – this is the basic concept of Mitsubishi elevators.

We at Mitsubishi Electric can introduce with all confidence our machine room-less elevator ELENESA, equipped with slim-line gearless traction machines (developed in-house). No matter what aspect you consider, be it layout, ride comfort or quietness, these are unparalleled landmark products. Technologies for the corporation's slim-line gearless traction machines will continue to evolve, and soon, based on these technologies, we will be able to ship product lines that cover all types of elevators from low-speed to ultra-high-speed models.

In addition to these products, through the pages of *Advance* we are introducing other new products and technologies that will lead the 21st century. Combining an accurate grasp of market needs with cutting-edge technologies generated by our ongoing research and development activities, and so continuing to produce technologies and products that can become global standards – this, I submit, is MELCO's mission as a leading manufacturer.

Mitsubishi Electric's elevators and escalators will always continue to evolve, in order to supply products of the highest quality, products that customers can use with peace of mind and no regrets over many, many years. □

**Yukio Kusuoka is General Manager of Overseas Marketing Division.*

The "ELENESSA" Machine Room-Less Elevator for Overseas Markets

by Hideaki Koderu and Takehiko Kubota*

Mitsubishi Electric Corporation has developed a new machine room-less elevator for overseas markets, the "ELENESSA," sales of which began in April 2001. ELENESSA elevators require less space for installation than any other elevator model in the industry and adopt universal design practice for greater convenience. This product conforms to EN standards, which pay full consideration to maintenance and to safety in the event of emergencies. This article discusses the concepts on which development of ELENESSA was based and describes the features and new technologies incorporated in this elevator series.

Product Concepts

In developing ELENESSA, Mitsubishi Electric engineers aimed at an elevator that would be used not only in Europe but also in Asia, the Middle East, and other world markets. Product development kept to the following three principles.

GREATER FREEDOM OF ARCHITECTURAL DESIGN. Engineers strove to reduce the space required for elevator installation, aiming at an easy-to-install elevator that would occupy the smallest amount of space in the industry, in order to make effective use of building space and to cut construction costs.

UNIVERSAL DESIGN. The concepts of universal design introduced in 1997 were taken further, with operation improved and panel indicators made easier to understand, so that the elevator could be readily operated by the elderly and by those with disabilities. The aim was to create an elevator that everyone would find easy to use.

EVOLUTION OF MITSUBISHI QUALITY. Another goal was to ensure the quality, performance and reliability that have traditionally distinguished the corporation's elevators, while adding further enhancements to an even safer and more reliable elevator product.

Product Features and New Technologies

SYSTEM CONFIGURATION. The traction machine, control panel and all other equipment are installed

within the elevator shaft, and the principal machinery has been made more compact for greater space savings. Fig. 1 shows the ELENESSA system configuration. The traction machine is installed at the upper end of the guiderails for counterweights, installed vertically in the elevator shaft; an underslung 2:1 roping system was adopted in which a counterweight is hung on a suspension rope. By employing a self-supporting design in which the traction machine and both ends of the suspension rope are supported by the upper part of the guiderail, the vertical-direction loads of the elevator are supported by guiderails, thereby alleviating the load placed on the building. The overall system configuration conforms to EN81-1 and to EN81-1:2000/prA2:2002.

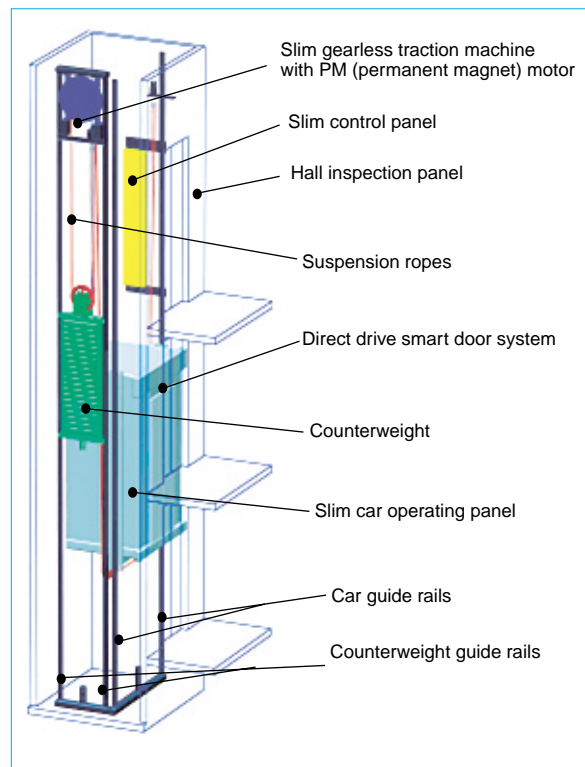

Fig. 1 Construction of ELENESSA

SLIM PM GEARLESS TRACTION MACHINE. As the traction machine, a slim gearless traction machine incorporating a permanent magnet (PM) synchronous motor was adopted. Fig. 2 is

*Hideaki Koderu and Takehiko Kubota are with Inazawa Works

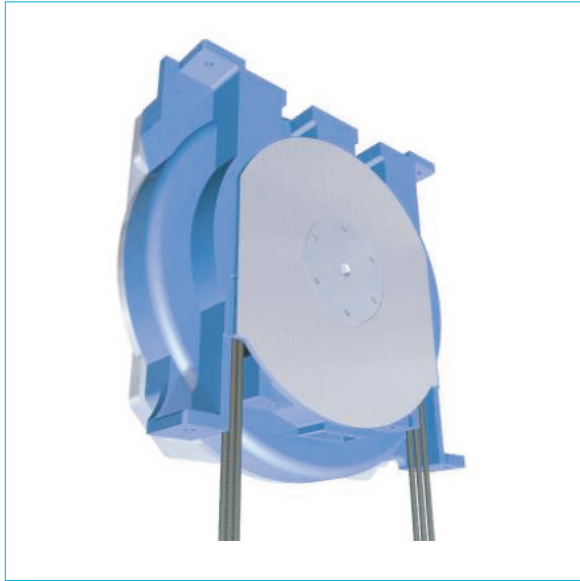

Fig. 2 Slim gearless traction machine with PM motor (3.7kW).

an external view of the slim PM gearless traction machine (3.7 kW). This equipment draws on the corporation's own closely wound stators and the development of compact double brakes for incorporation in traction machines, helping to reduce the equipment radial thickness to 187 mm (one fifth or less than that of previous models) at a rating of 3.7 kW. Motor-torque ripple was reduced through magnetic pole analysis techniques, for a smoother, more pleasant elevator ride.

SLIM CONTROL PANEL. Because the control panel needed to be installed in the limited space between the car and the elevator shaft, a slim control panel only 98mm thick and 340mm wide was newly developed. Fig. 3 is an external view of this panel. The control and driving circuitry assembled within the control panel consists of two types of highly integrated subunits, an integrated power unit (IPU) and a control processing unit. The IPU integrates a DC/DC converter specifically for elevator control with an inverter for elevator drive, based on an intelligent power module (IPM), over a single heat sink, to obtain a highly integrated power supply and driving unit with a thin shape. The control processing unit is equipped with a large-scale system LSI for elevator equipment for more functionality and a higher level of integration.

DIRECT-DRIVE SMART DOOR DEVICE. A slim PM synchronous motor was newly developed for the door-drive motor, adopting a direct-drive design without a decelerator; the door-drive motor was incorporated in the door device (Fig. 4). In this

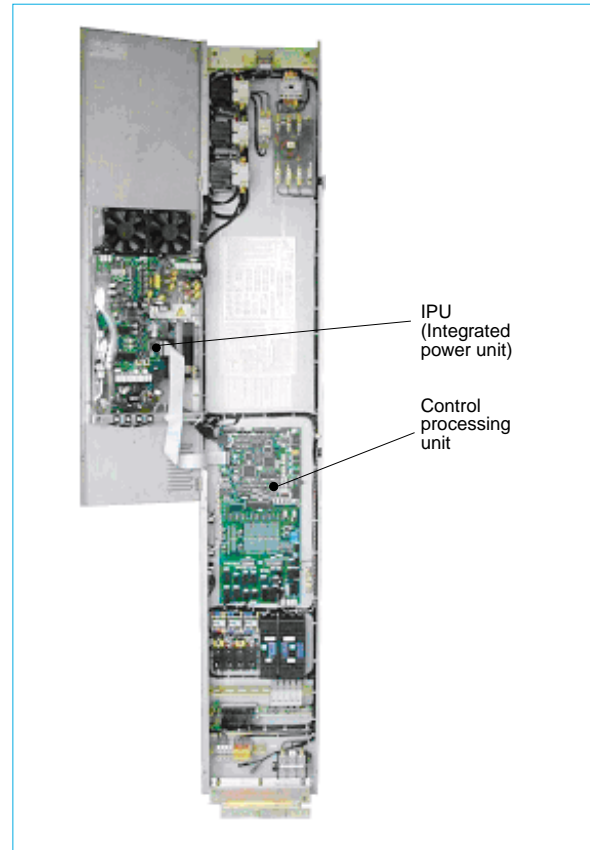

Fig. 3 Slim control panel

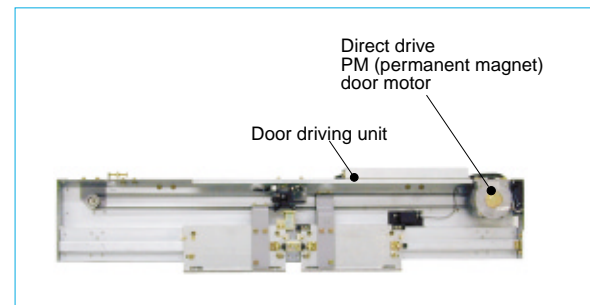

Fig. 4 Direct drive smart door system

way, the space occupied is reduced to just 60% of the volume of conventional door devices, for a dramatic improvement in layout freedom and substantial space savings. Also, the door-drive unit has an auto-tuning function that monitors the weight and condition of the doors on each floor and optimizes door opening/closing. As a result, door opening/closing performance is smoother and more stable.

COMPACT GOVERNOR. Installed at the top of the elevator shaft, this compact governor is reduced to just 60% of the size of conventional equipment. A remote-operation mechanism is provided so that tests to confirm operation during inspections, and operation in the event of an

emergency, can be performed from the hall without accessing the elevator shaft.

SLIM CAR-OPERATING PANEL. The newly developed car-operating panel is slim (only 25mm deep) and can be housed within a panel in a car side wall. As a result, the dimensions of the elevator shaft can be further reduced.

UNIVERSAL DESIGN. The universal design adopted for existing GPQ models has been further extended and a design developed with care taken to ensure ease of use by everyone. Fig. 5 shows an example of this universal design. The car-operating panel is positioned on a side wall of the car so that it is immediately visible on entering the elevator. Button positions and heights are also set such that even children and persons in wheelchairs can operate the elevator. The indicator characters in the car are enlarged to 1.6 times their usual size, making them easy to read. Also, the characters in the buttons of the car operating panel and in hall call buttons are embossed, so that they can be touched and understood by persons with impaired eyesight. Finally, by enlarging the open-door button within the car compared with other buttons (by 1.6 times), the chances that the wrong button will be pressed are reduced.



Fig. 5 Universal design for car

SAFE MAINTENANCE ON THE CAR ROOF. Maintenance of the traction machine, control panel and other equipment installed in the elevator shaft is performed on the roof of the car. To ensure greater safety for these maintenance operations on the car roof, it has a flat, non-skid surface

and adequate space for maintenance is provided. To further ensure safety, a car-locking device is provided to mechanically prevent any unexpected movement of the car during maintenance.

HALL-INSPECTION PANEL. A hall-inspection panel is built into the hall call button panel on the top floor, so that the elevator can be operated without entering the elevator shaft during maintenance inspections and in times of emergency. In addition to indicators showing the elevator stage, the hall-inspection panel includes an operating switch for use in maintenance and inspections, an emergency rescue operation switch, an emergency stopping device, and other devices and functions to ensure the operation of safety mechanisms. The hall-inspection panel is installed within a box behind the hall call button panel on the top floor so as not to compromise the aesthetics of the hall (see Fig. 6).



Fig. 6 Hall inspection panel behind hall call button

The new features and new technologies of the ELENESA elevator, sales of which commenced in April 2001, are a landmark in Mitsubishi Electric's ongoing commitment to make further advances in speed, capacity, and other areas. We will be working to develop technologies for the further evolution of the corporation's elevator products. □

Reference

[1] Yoshikatsu Hayashi, Shigeki Yamakawa, and Takashi Yumura: "The ELEPAQ-i Mitsubishi Machine Room-Less Elevator", Mitsubishi Electric Technical Journal, 75, No. 12, 766-771 (2001).

New Traction Machine for Machine Room-Less Elevators

by Kenji Inoue and Nobuaki Miyake*

Mitsubishi Electric Corporation has developed a new traction machine for machine room-less elevators. The world-leading slim form factor provides for great convenience in layout design. In addition, the slim traction machine also runs smoothly, ensuring a comfortable ride, and can be manufactured with high productivity. This article introduces the structure of this slim traction machine and the motor technology that made it possible.

Features of the Slim Traction Machine

As well as possessing the basic functions and performance required of drive equipment for elevators, the new traction machine for machine-room-less elevators had to be compact and quiet. With the GPQ series, which the corporation first marketed in 1999, we eliminated the need for a machine room by using permanent magnet (PM) synchronous motors to develop a cylindrical form of gearless traction machine. Now, we have developed the new slim traction machine, designed to be flat and thin, to improve the machine layout in the hoistway. Fig. 1 shows the new slim traction machine, released in October 2001, that was developed for ELENESSE elevators. Its features are listed below.

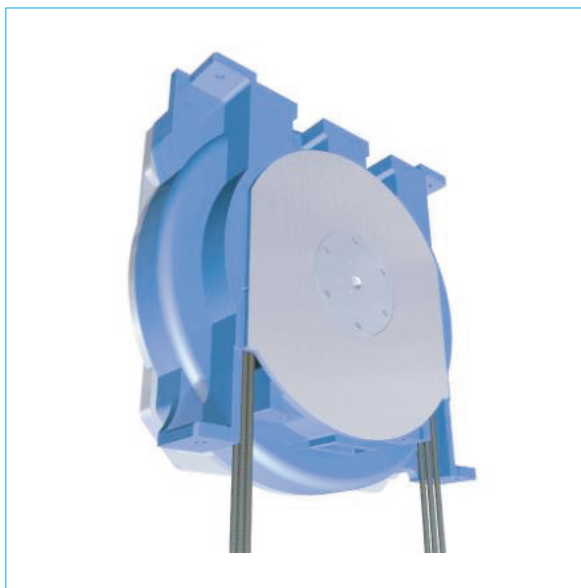

Fig. 1 External view of slim traction machine.

First, the size has been reduced to a world-leading slim form factor. In addition to implementing the corporation's proprietary joint-lapped core, the rotor, sheaves, brakes, and encoder were all included in the unit. In the 3.7kW model we achieved a unit that was 187mm in axial dimension, less than 20% the size of the previous product.

Second, the ride is comfortable. Using the corporation's expertise in magnetic field analysis, we reduced torque ripple. The result is a ride that lives up the long-standing reputation of Mitsubishi elevators for quiet and smooth-riding comfort.

Third, productivity is excellent. As well as implementing automated winding of the motor through the use of concentrated winding techniques, the assembly procedures were also simplified by integrating the rotor, sheaves and brakes into a single unit, while at the same time adopting other methods of raising productivity.

Traction Machine Structure

Fig. 2 compares the structure of the previous traction machine and the recently developed slim traction machine. As long as the sheaves, motor, brake and encoder were set in series along the same axis, the space required to accommodate this configuration limited the possible reduction in length. In the slim traction machine, the motor's rotor has been given a hollow cylindrical form and this allows the inner surface to be used for an internal expanding double brake. Moreover, the encoder has been installed within the space inside the brake mechanism. Then, by integrating the rotor and sheaves within the unit itself, and by dispensing with coupling parts, the dimensions of the equipment were reduced and reliability was raised. Overall, denser mounting of the internal components of the traction machine enabled minimization of the external dimensions.

Furthermore, the ultimate form and configuration of the main unit were decided after structural analysis to ensure adequate strength and rigidity under loads encountered in normal running, at emergency stops, during manufacture, and under various other conditions.

*Kenji Inoue is with Inazawa Works and Nobuaki Miyake is with the Manufacturing Engineering Center.

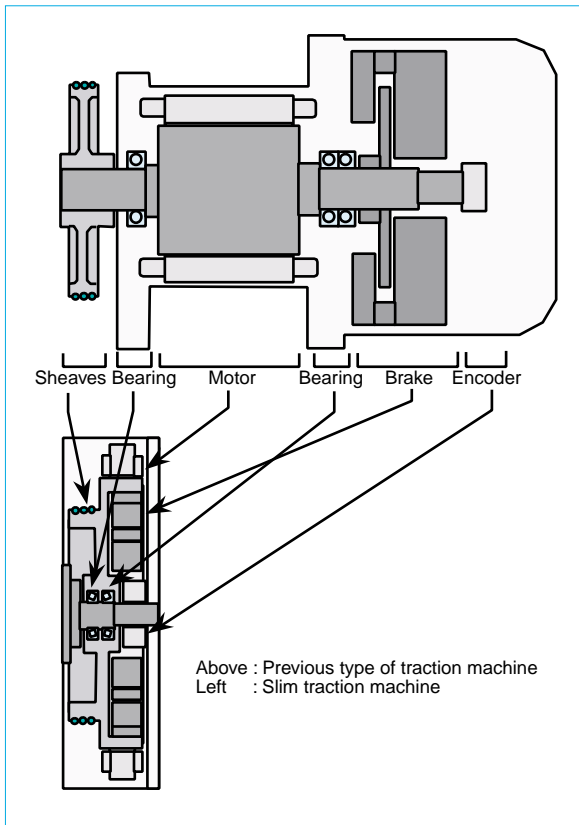

Fig. 2 Comparative structure of traction machines.

Ultimately, along with reduction of the size of the motor, brakes, and other elements, structural analysis enabled us to optimize the form of the equipment so that the 3.7kW model of the slim traction machine weighed only about 300kg, some 33% less than the equivalent previous model.

Motor Electromagnetic Engineering Design

For machine room-less elevators Mitsubishi Electric implemented PM synchronous motor technology that combined compact form and high torque at low speed. During the development of the slim motor, as in the past, we adopted high-performance rare-earth magnets. There were four other additional main design features: concentrated winding methods; high density of ampère-conductor; larger diameter; and multi-pole configuration.

Compared with distributed winding, concentrated winding enables reduced motor size because coil ends are smaller. Besides this, we

were able to apply proprietary joint-lapped core technology to achieve both high density winding (and therefore higher ampère-conductor density), and improved productivity through automated winding.

Multi-pole design is a common approach to down-sizing motors. As shown in Fig. 3, in this motor it enabled shortening of the coil ends and reduction of the radial dimension of the motor. In multi-pole designs, the magnetic flux between the poles can be weaker at smaller pole pitches. This allows the core back of the iron core to be thinned and also makes it possible to reduce the radial thickness of the stator and rotor. Moreover, because a big space within the rotor became available, in this case it became possible to mount the brake there, thus enabling a compact design for the entire traction machine.

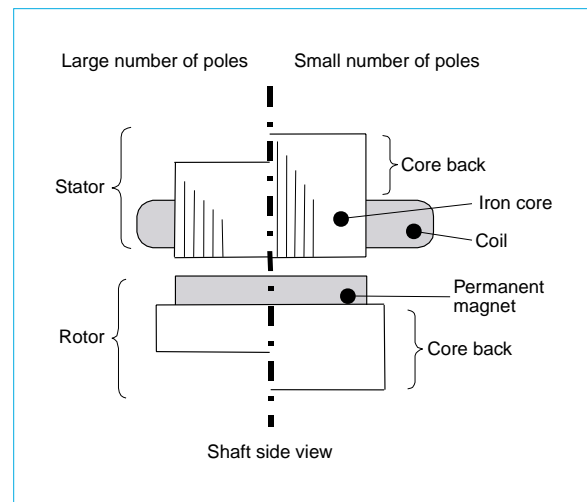

Fig. 3 Effect of multipole design.

Motor-Manufacturing Technology

In the development of any high-performance motor it is important to review the basic structure of the motor from the point of view of manufacturing productivity. Once the fundamental design is settled, it is no longer possible to make extensive improvements in working procedures and assembly, and further dramatic improvements in the overall motor characteristics are not to be expected.

As Fig. 4 shows, at Mitsubishi Electric we have developed a "joint-lapped core" technology that features flexible joints. The joint-lapped core is able to open and be bent back at the joint for winding

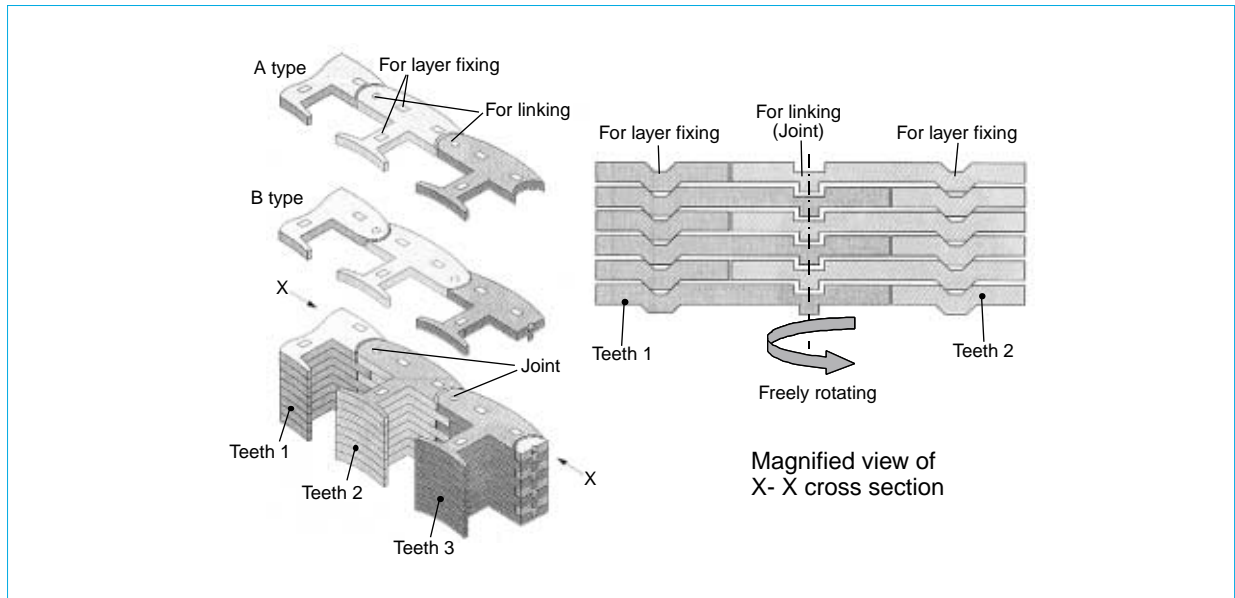

Fig. 4. Structure of articulating joint-lapped core.

easily. This design has been applied to various of the corporation's motors. For each product, the coil space factor has been greatly improved. As well as achieving lighter, more compact motors with higher efficiency, we are moving towards complete automation of winding.

Built up in successive layers with high precision, the joint-lapped cores are straightened in position after extraction from high-speed presses. The forms in the presses work on flat rolled magnetic steel that is fed in strips. By synchronizing the feed switching from multiple dies and punch blades, the structure is built up and an arrangement of flexible articulating joints is produced.

As shown in Fig. 5, while winding, the joint-lapped core is bent back at the joint. The coil-winding nozzle can be moved in a circular locus because free space is available around the teeth. This means that no distortion arises by adding unnecessarily to coiling wire. It is possible to achieve perfect coil alignment with thick wire coils. Moreover, rather than using a single iron core with large diameter, the joint-lapped core is radially divided. This increases the yield when the cores are stamped and improves transport efficiency during stator production.

Torque Ripple Reduction

To ensure a comfortable elevator ride, one of the technologies that Mitsubishi Electric has been

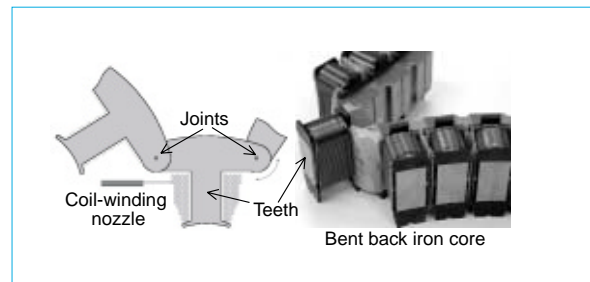

Fig. 5. Iron core at time of winding.

successfully adopting is motor-torque ripple reduction. In the recently developed slim traction machine, there was initially a tendency toward increased torque ripple because of the marked size reduction and the use of a concentrated winding method. Torque ripple was greatly reduced, however, by considering magnetic saturation and potential production errors at the design stage. The resulting slim traction machine provides the same smooth riding comfort that has always been the mark of Mitsubishi elevators.

The slim motor design features high density of ampère-conductor. Consequently, torque ripple tends to increase because stator teeth are easily subject to magnetic saturation during high current loads. After using magnetic field analysis to investigate different forms and dimensions of teeth, we abandoned the previous semi-closed

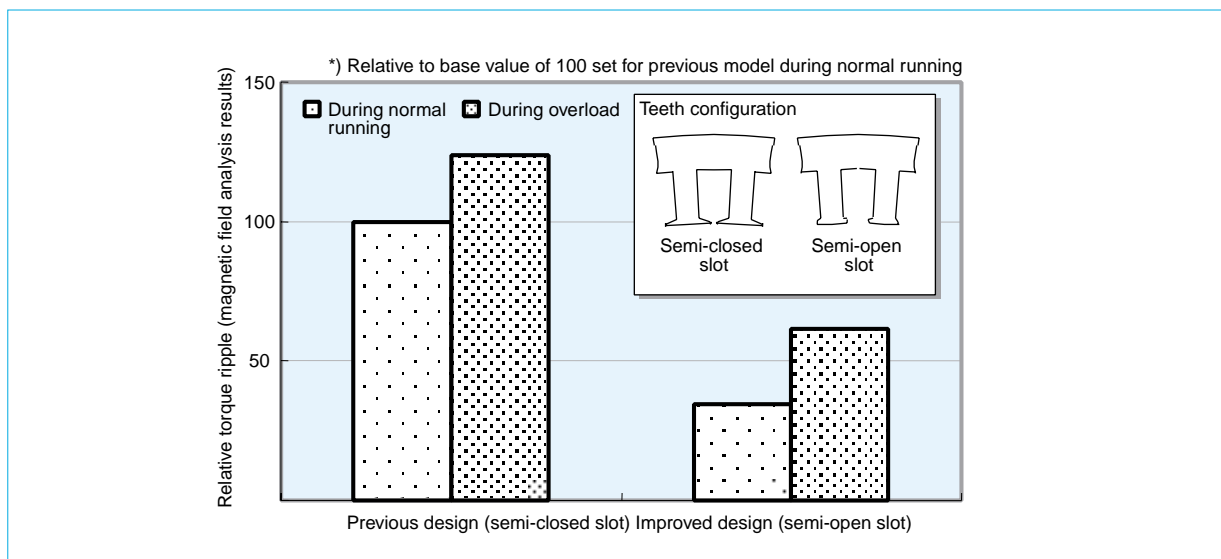

Fig. 6 Comparative torque ripple results.

slot for a semi-open slot design. Consequently, magnetic flux leakage from the tips of the teeth mitigated magnetic saturation. This change, as shown in Fig. 6, halved torque ripple during overload and cut it by a third during normal running. The overall result was to reduce torque ripple across a broad range of operation.

Errors that occur during manufacturing processes increase torque ripple and cause product variations. We therefore analyzed the types of manufacturing error that can lead to torque ripple. To thoroughly clarify the relationship between such working errors and torque ripple, we freely applied magnetic field analysis in virtual engineering. Reflected in both motor design and production management, the results of this analysis brought about the benefit of motors with low torque ripple and consistent production.

As well as finding ways to extend the applications for slim traction motors, we are committed to further improving elevator product performance and quality. We remain determined to develop attractive products that have winning appeal. □

“Universal Design” in ELENESSE (Machine Room-Less) Elevators

by Kazuko Matsuda and Masayuki Miyawaki*

Universal design implies the creation of products that are easy for all to use irrespective of age or disability. The concept of universal design is central to Mitsubishi Electric’s machine room-less ELENESSE elevators; newly added features include side-panel mounted car-operating panels and raised character buttons.

Universal Design for Elevators

To summarize, universal design is design that everyone finds equally easy to use. “Everyone” here specifically includes people with disabilities and the elderly along with regular users. With deepening understanding of aging societies and their physically or otherwise challenged members, universal design is becoming more important in a number of fields.

Elevators perform the function of vertical transport for their users, and they operate under very simple controls, but in the limited space of an elevator car it is extremely difficult, and therefore important, to create interfaces that are equally easy to use for each of a number of unspecified users.

On a global scale, as many efforts are being made to improve the mobility of the disabled, there are more countries that have legislation covering disabled persons and elevators; incorporating universal design in products is therefore becoming essential.

Also, we should work to improve the elevator experience, relieving the unease users may feel while they are cooped up in the elevator car, and the impatience they will feel while waiting at the landing.

Mitsubishi Electric’s new machine-roomless ELENESSE elevator is based on universal design, and the article describes its use in this product.

Main Universal Design Features in the Operation and Display Devices

SIDE-PANEL MOUNTED CAR-OPERATING PANELS. The car-operating panel is depicted in Fig. 1. By moving car-operating panels from beside the doors (the front return panels, where they have previously been mounted) to the side panels, we achieve the following benefits:



Fig. 1 Car design

It is easier to find the car-operating panels when entering the elevator (they catch your eye as the doors open).

Users in wheelchairs can operate the car without having to wheel themselves around (or reach back over their shoulder) within the car. Even for non-wheelchair users, not needing to turn around to get the car moving means greater ease of use.

Building Regulation 1999 M2 (of the United Kingdom) stipulated that the appropriate mounting location for a car-operating panel is the side panel, at least 400mm away from the front wall. The reason for this appears to be to make it easy for users in wheelchairs to use the buttons after entering the car. For this product, we paid strict attention to ease of use, and decided to mount car-operating panels in locations which would satisfy the condition described above.

MOUNTING HEIGHT FOR BUTTONS. Legal codes such as the Building Regulations, Approved Document M2 of 1999 (of the United Kingdom) and Code on Barrier-Free Accessibility in Buildings 1995 (of Singapore) have stipulations regarding the mounting height for car-operating

*Kazuko Matsuda is with Inazawa Works and Masayuki Miyawaki is with the Industrial Design Center.

buttons, based on considerations of the issue of operability by the disabled. For this product, based on these code stipulations, we have located car-operating buttons between 900 and 1200mm above the car floor. Also, by putting the Open, Close and Alarm buttons below the Floor buttons, even those who cannot reach very high can readily operate them. Thus, even if children or others whose hands cannot reach very high enter the car by mistake, our design allows them to avoid entrapment by using the Open button. Also, if an entrapment were to take place, parties outside the car can be notified through use of the Alarm button.

SYMBOLS ON OPERATING BUTTONS. A general view of the operating panel is given in Fig. 2. Embossing the numbers and symbols found on operating buttons enables them to be read by touch. This aids users who are visually handicapped but do not read Braille.

Numbers and symbols are raised 1mm above the button surface; we determined the precise embossing patterns to use based on evaluative

tests performed with 20 men and women with impaired vision (including individuals with weak eyesight and the totally blind, both those born with impaired sight and those whose vision was later impaired). In these evaluative tests, we prepared various different samples with many embossing patterns, and had the subjects evaluate the relative ease of understanding buttons by touch (Fig. 3 and 4). As a result, it became clear that readily understood designs were those where the embossed edge was thin, and the patterns were clearly raised above the button surfaces.



Fig. 2 Car-operating panel



Fig. 3 A scene from testing

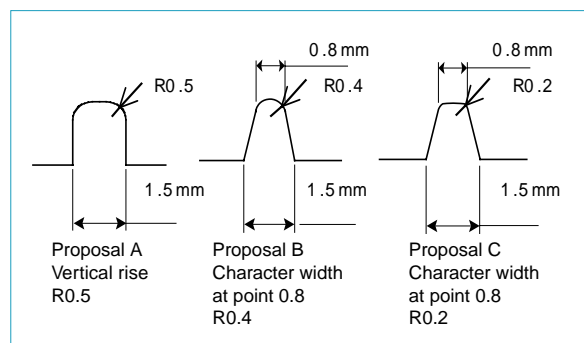

Fig. 4 Cross section of sample embossed characters

In evaluating embossing patterns, it became clear that ease in understanding by means of touch is influenced by choice of character fonts, and so we adopted a character font more easily

distinguished than our previous choice (Fig. 5). For instance, when compared to the previous font, the difference between “6” and “9” is much clearer in the new font, and is readily distinguished even by those with weak sight.

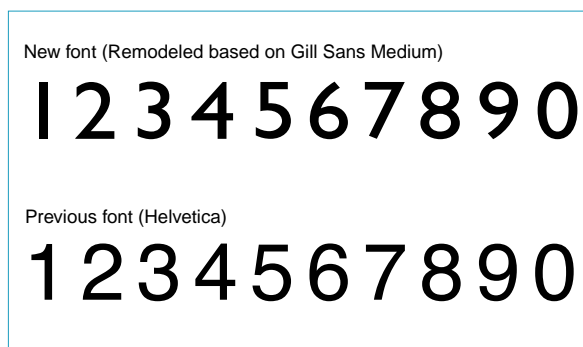

Fig. 5 New numeral designs for buttons

Also, car buttons for the main floor have been made green, and raised about 5mm more than other buttons. This is done in order to make it easier to detect evacuation floors in case of disasters; these main-floor buttons stand out above the other buttons, so even the visually impaired can readily distinguish evacuation floors.

ENLARGING THE OPEN BUTTONS. Since it is hard to distinguish immediately between the Open and Close buttons, we have changed the size of the Open button as shown in Fig. 2, making it easier to recognize it instantly. We chose the Open button to make it easier to use, since it may need to be used instantly.

CAR INDICATORS. We enlarged the character size in car indicators (about three times the surface area of previous models), thus improving visibility.

Major Universal Design Features for the Car and Landings

DOORS WITH LARGE WINDOWS. Doors with large windows have been added as an option. Installing windows in the door has the effect of alleviating the sense of confinement within the

car, improving the car’s anti-crime profile and providing a greater sense of freedom while within.

CAR MIRRORS. We have added an optional full-height mirror running from floor to ceiling. To keep this from being a hindrance to car passengers, the face of the mirror is flush with the car wall, eliminating any protrusion into the car.

HANDRAILS. We expanded the handrails to a diameter of 38mm (32.5mm in previous models), based on anatomical research data, and made it easier to grip. Also, we will put the plaquette portion at an angle as shown in Fig. 6, improving the join of the corners to the wall so that clothes, etc., will not get caught on handrail ends.



Fig. 6 Handrails

We investigated laws throughout the world written considering the physically handicapped, and have been able to create a product that satisfies both ease-of-use demands and legal requirements. However, when considered in terms of the lofty ideal of universal design— easy use by anyone— we would claim no more than that this product is a step in the right direction. We are committed to achieve further and greater improvements in this direction. □

References

1. Office of the Deputy Prime Minister, Government of the United Kingdom, Building Regulations Approved Document M, Section M2 (1999).
2. Ministry of National Development, Building Construction Authority, Building Control (Singapore) Code on Barrier-Free Accessibility in Building 1995.

The New Σ AI-2200 Elevator Group-Control System

by Masaaki Amano and Toshio Masuda*

The Σ AI-2200 system incorporates new functions such as a dynamic rule-set optimizer that selects the appropriate rule according to changes in traffic conditions, a destination oriented prediction sub-system that controls car allocation according to the destination floor, etc., by adopting new technologies such as high performance RISC processors, a real-time OS and a network dedicated to group control using Ethernet.^[1]

Background

With advances in the application of intelligence to today's increasingly complex buildings, we have entered an age where high performance and diverse functions are being sought in the group-control system for elevators. In conventional group-control systems, a fixed car allocation rule set was used for each traffic pattern (e.g., if it was the morning rush hour, the general purpose rule set for the morning rush hour was used). However, traffic is different for each building and car allocation applied with the general-purpose rule set may not always be optimal. Therefore, a new system called the dynamic rule-set optimizer was developed for the Σ AI-2200. This system performs a simulation on a number of morning rush-hour rule sets prepared in advance with a real time simulator loaded in the Σ AI-2200 and selects the optimum rule set.

This system was configured to enable the group-control system to be provided with a simulator for verifying the effect of group control as conventionally performed using personal computers. This simulation requires a high arithmetic performance from the main computer that performs the group-control arithmetic. The performance of microcomputers has improved noticeably in recent years and generic RISC microprocessors capable of high-speed arithmetic operations are available. A RISC processor is employed as the main computer for group control in Σ AI-2200 to implement the real-time simulation function mentioned above.

Also, with enhanced group-control performance and the addition of new functions, there is a need to strengthen communications between the group control and the elevator con-

trol panel and between the group control and the hall operating devices. Communication technology has scored remarkable advances in recent years, demonstrating high communication performance and reliability. Application has now become possible even for communication between the devices of elevators requiring high communication performance and reliability.

System Configuration

Fig. 1 shows the system configuration. It features the group-control CPU card with improved arithmetic performance and the communication network with enhanced and expandable communication capabilities.

CPU Board for Group Control

Fig. 2 shows the appearance of a CPU board for group control. A CPU is provided for each assigned function on the board and there are three CPUs, namely, a RISC processor for performing the main arithmetic for group control such as allocation, learning, etc., a CPU for communication control, and a CPU for general purpose I/O control. In order to obtain the high arithmetic performance particularly necessary for real-time simulation, a type with a floating-point co-processor was selected for the group-control arithmetic RISC. The clock runs at 200 MHz. Also, a real-time OS with the μ TRON 3.0^[2] specifications has been loaded in order to enhance the reliability of the system.

Due to the optimization of the bus between the RISC and the peripheral devices, the high speed clock at the core of RISC, and having optimized the S/W configuration so that the instruction cash and data cash function effectively as described above, improvement in the group control main arithmetic performance of about ten times that of the conventional group control system was achieved.

Communication Network

The communication system comprises a group control-control panel communication network (or more briefly, "group-control network") and an optional network that connects the new hall devices, etc.

*Masaaki Amano and Toshio Masuda are with Inazawa Works.

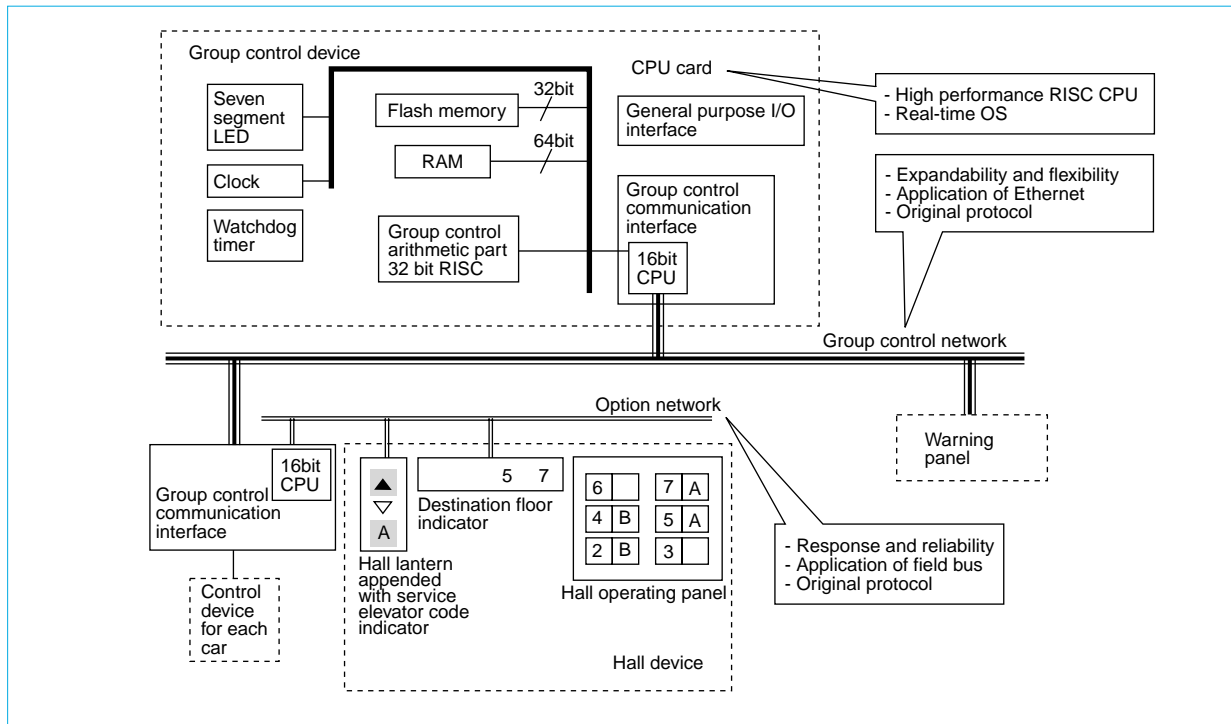

Fig. 1 System configuration

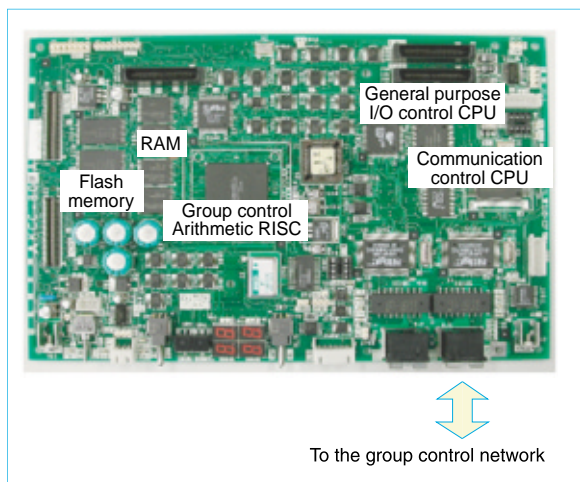

Fig. 2 CPU board for group control

Classifications of the OSI reference model		Network specifications for each group
Layer	Name of layer	
7	Application layer	Application
6	Presentation layer	
5	Session layer	Data management
4	Transport layer	
3	Network layer	Failure management Boarding/exiting control
2	Data link layer	
1	Physical layer	Token control 10BASE-T

Fig. 3 Protocol construction of group-control network

Fig. 3 shows the protocol of the group-control network. This group-control network used Ethernet for the physical layer of the network in order to secure expandability and flexibility for the future and to create a network suited for the recent intelligent building systems.

Furthermore, to enhance the reliability of the communication system and to secure adequate response, a node-separating function has been provided for cases where a new connection or failure in the network node is generated. Consequently, adequate network reliability has been secured so that device additions or node failures do not influence the whole network.

Improved communication capabilities are essential in the destination-oriented prediction system discussed below. Therefore, response and

reliability were secured by means of a data-collision bypass protocol and an optional network based on a field bus of superior expandability for device additions. With this optional network, the communication capabilities improve and even the restriction on the number of floors installed with a hall operating panel is relaxed considerably.

New Functions

DYNAMIC RULE-SET OPTIMIZER. The dynamic rule-set optimizer is realized by combining three sub-modules, neural networks, a group-control rule base, and a real-time simulator as shown in Fig. 4.

The neural networks detect the traffic patterns during the morning rush hour, regular hours, etc., as well as performing a more detailed estimate of the traffic data and outputting the estimated data. The group-control rule base is stored with each set of rules peculiar to a specific traffic condition as a group-control rule set. Also, a

number of rule sets capable of optimization are selected as rule-set candidates according to the detected traffic pattern. The real-time simulator performs its simulations when the rule-set candidates and the estimated traffic data are input, and then the waiting time and the service completion time are output for each rule set. The optimum rule set is selected based on this output. In group-control execution, controls such as call allocation, dispatching of cars, etc. are executed in accordance with the optimum rule set.

DESTINATION-ORIENTED PREDICTION SYSTEM. A hall operating panel that replaces the conventional UP/DOWN type hall buttons is installed at the hall on the lobby floor. Fig. 5 shows the configuration of the device. In this hall operating panel, a service-elevator code indicator that shows the assigned service elevator code was mounted near the destination buttons so that the passenger who pushes the

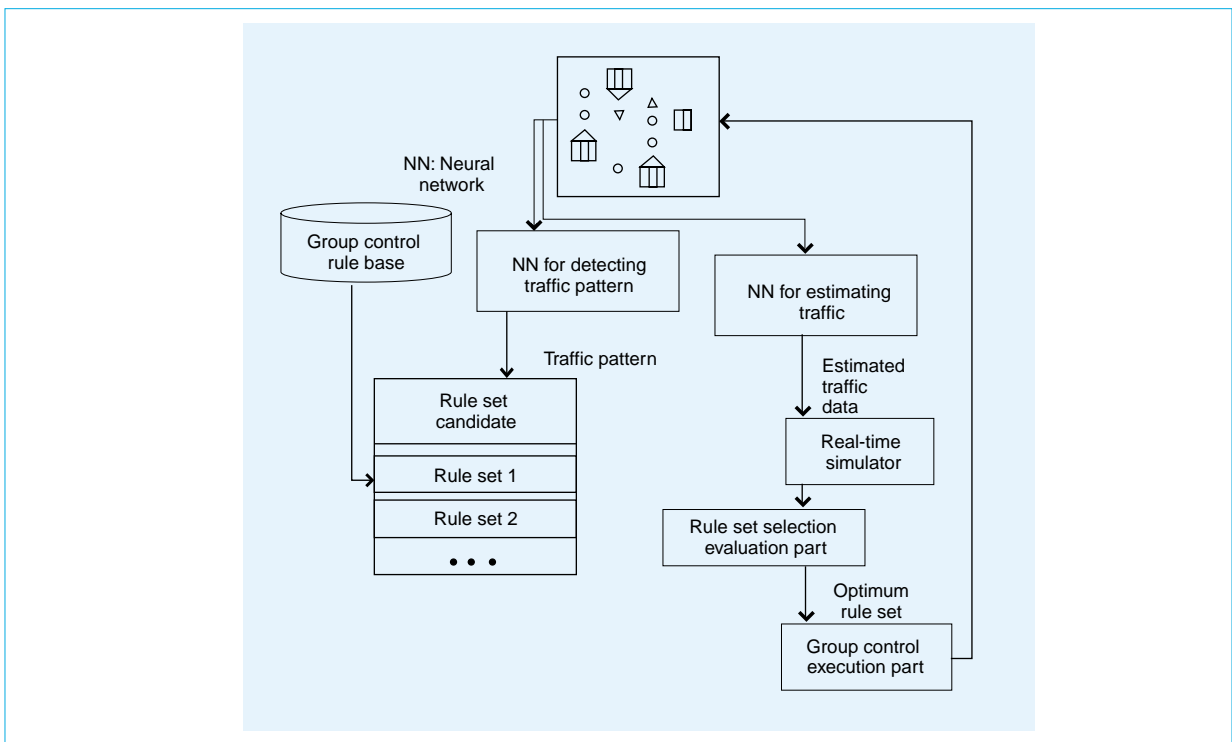

Fig. 4 Dynamic rule-set optimizer

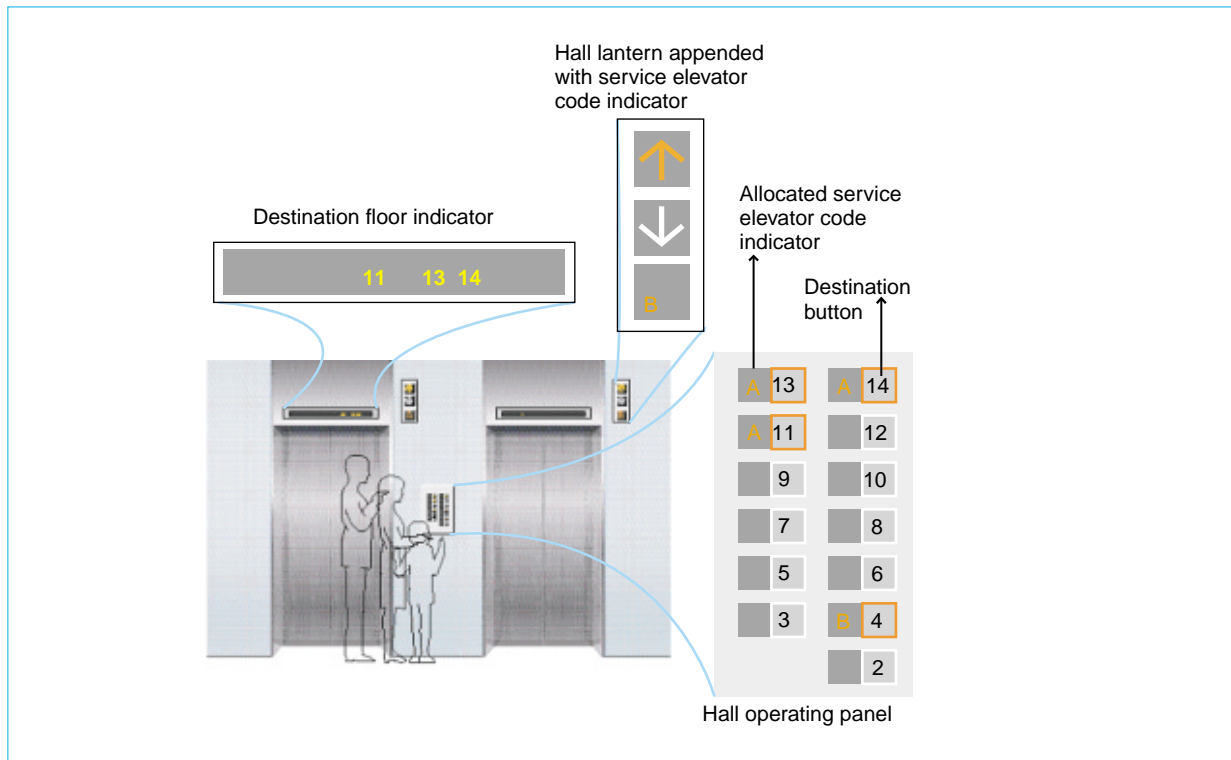

Fig. 5 Destination-oriented prediction system

destination button can know the code of the assigned service elevator immediately.

Operation is as follows. When it is the morning rush-hour zone and up peak time is detected by the neural network, dispatching of cars according to the respective destination floor (car allocation tuning) takes effect. During this time, the elevator transports the passenger to the destination floor according to the following sequence.

1. The optimum car is selected for each destination call made at the hall and this is notified to the passenger with the hall lantern and the service-elevator code indicator.
2. The maximum number of possible destination call registrations allocated to one car is determined according to the aforementioned dynamic rule-set optimizer and if destination calls in numbers exceeding this value are registered, a newly predicted car is selected in compliance with the destination call.

3. When it has been detected that the passenger has boarded the predicted car, the destination call allocated to the pertinent car is registered automatically.

By applying the destination-oriented prediction system, the number of destination calls for each car per run can be reduced due to the effect of car allocation tuning, the transport efficiency is improved, and the congestion at the lobby floor can be minimized.

In the future, we intend to make further advances in elevator group-control systems such as interlocking with the building security system, etc., to further accommodate the application of intelligence in buildings. □

References

- [1] Ethernet is a registered trademark of Xerox Corporation.
- [2] μ ITRON is Micro ITRON, ITRON is Industrial TRON, and TRON is an abbreviation for The Real Time Operating System Nucleus.

The Overseas Version of the MIC & Remote Maintenance System

by Yasuhiko Tanabe*

The overseas version of Mitsubishi information center (MIC) and remote maintenance systems will improve maintenance inspection techniques and capabilities in responding to fault conditions in Mitsubishi Electric Corporation's elevators overseas, and will also make it possible to handle remote maintenance, which is beginning to be implemented in world markets.

At present, overseas MIC systems are being implemented by International Elevator & Equipment (Philippines), as well as companies such as Ryoden (Malaysia), Worachak International (Thailand), Mitsubishi Electric Saudi (Saudi Arabia) and P.T. Mitsubishi Jaya Elevator and Escalator (Indonesia). This is bringing significant performance improvements.

We are also seeing the introduction of remote maintenance systems, from Shanghai Mitsubishi Elevator Co. (China), through Ryoden Lift Services Limited (Hong Kong) and ETA-MELCO Elevator (U.A.E) to China Ryoden Co. (Taiwan). Shanghai Mitsubishi Elevator Co., Ltd. plans to install 500 remote maintenance systems in this market during the current fiscal year.

The corporation's plans involve constructing a world-wide network that links the domestic MIC system with overseas MIC systems, as we further envision the possibility of supporting from Japan the collection and analysis of diagnostic elevator data by means of remote maintenance in conjunction with fault data and customer information.

System Configuration:

The overseas version of the MIC/remote maintenance system allows the unified supervision of all circumstances related to fault repairs through telephone contact with our clients and through receipt of signals from monitored elevators. We developed this overseas version by identifying the minimum essential functionality within our Japanese system, see Fig. 1.

This system is made up of a client/server type personal-computer based MIC system (with Windows NT operating system and an ORACLE database) and a remote maintenance system,

where software for remote maintenance is loaded into the elevator's operating panel.

As subsystems under both of these systems, we will set up communications control devices (devices with automatic incoming/outgoing phone-line control functions), establishing data transmissions between the call center and elevators over public phone lines.

Functions and their Effects—the MIC system.

RECEIPT OF MALFUNCTION REPORTS. Telephone contacts with customers and the receipt of elevator signals are all drawn together and dealt with at call center.

Since this makes it possible to conduct detailed breakdown analyses using accumulated field data, this can lead to improvements in the quality of maintenance work and strengthen callback service (CBS) management capabilities. (CBS is used to identify a breakdown-response system where maintenance personnel are sent out immediately after receipt of a dispatch request from customers, or once we receive a "dispatch signal" transmitted under the maintenance operations protocol of a remote monitoring device.)

Furthermore, it is possible to record contract information that goes beyond customer information and the points of concern in dealing with customer issues. This other information can then be utilized in what we may translate as a registry of simple maintenance contracts and for various types of administrative data.

SUPERVISING DISPATCHES FOR FAULTS. Elevator by elevator, we are managing the whole sequence of events from the occurrence of the fault (whether learned about by transmissions from a remote monitoring device or communicated over the telephone) to the order for dispatch of personnel, the actual dispatch, arrival of the maintenance team and completion of repairs.

Based on this, it is possible to confirm and follow through the status when any aspect of fault repair is omitted or delayed, or when repairs are prolonged. Furthermore, it will be possible to inform owners and management companies

*Yasuhiko Tanabe is with Mitsubishi Electric Building Techno-Service Co., Ltd.

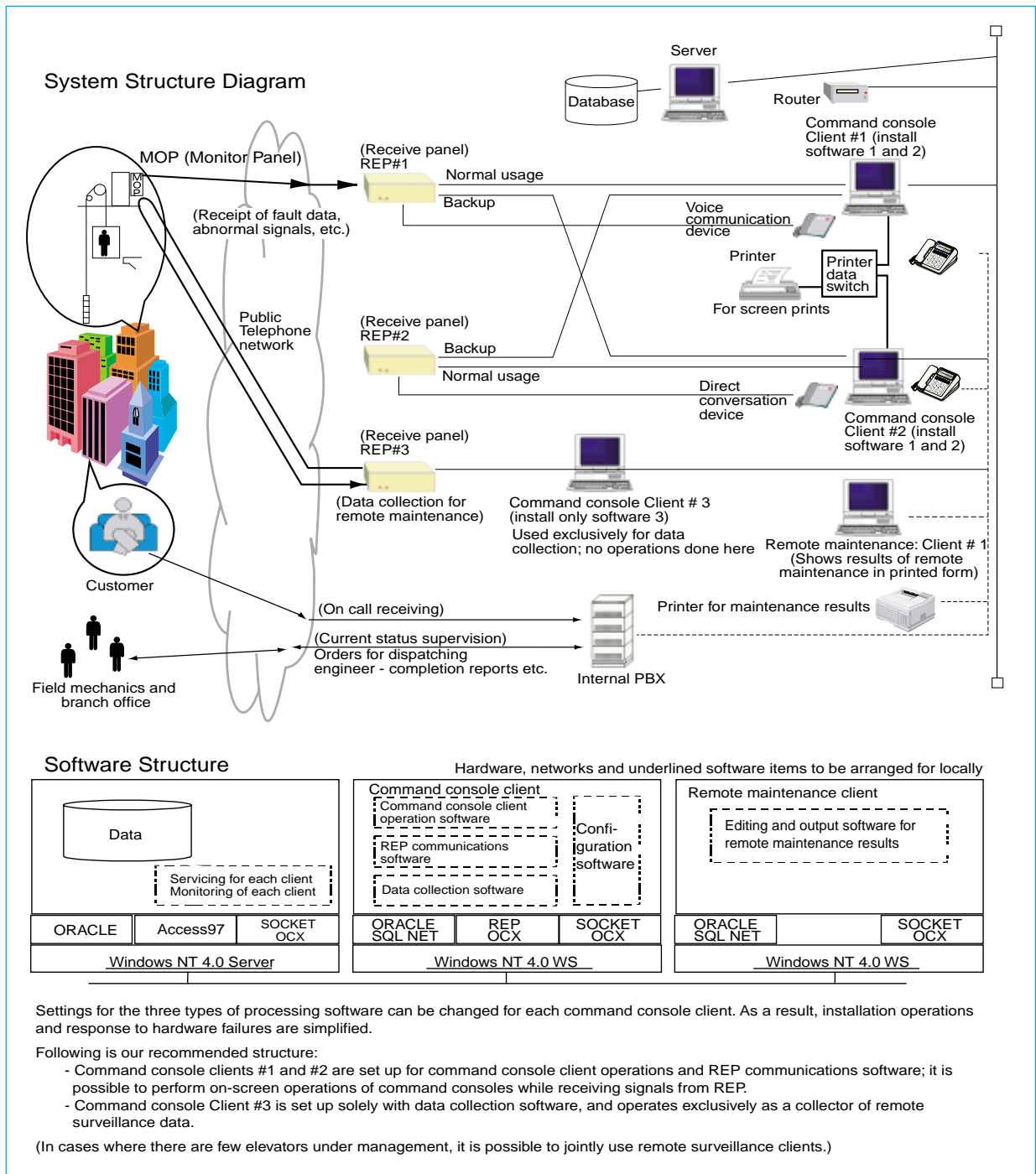

Fig. 1 Description of the overseas MIC/Remote Maintenance System

immediately in response to their inquiries on how faults are being handled.

These capabilities are the basis for the powerful appeal of this system to customers, for it enables swift response to breakdowns, and its installation will provide them premier elevator performance.

BREAKDOWN STATISTICS/ANALYSIS (an export tool). Through this export tool, it is easy to acquire the necessary data from accumulated customer information, elevator specification information and fault data that has been entered into the system.

The resultant quick and easy analysis and collection of data on fault details makes it possible to provide rapid support for data feedback to the manufacturer and proposals to reduce the recurrence of faults.

Remote Maintenance System

NOTIFICATION OF FAULTS AND ABNORMAL CONDITIONS. This function automatically notifies the call center when elevators malfunction.

In addition to the details of the malfunction, information on the floor where the malfunction occurred and data on factors that may be presumed to have caused the malfunction is also provided.

This function has made it possible to maximize the unique capabilities of microcomputers and so to carry out continuous remote electronic monitoring twenty-four hours a day, 365 days a year. This is very different from the necessarily fragmentary inspections normally carried out by our maintenance staff, and offers major benefits as a public relations tool with respect to customers.

VOICE COMMUNICATION FUNCTION. This function permits conversation over a communications device between people trapped in the elevator and personnel in the call center, should a malfunction result in entrapment or an elevator be rendered inoperable.

Since this allows command center personnel to transmit appropriate instructions to people trapped in the elevator, those entrapped can feel reassured, and content to wait until help arrives.

REMOTE MAINTENANCE FUNCTIONS. Here we have two types, irregularity-detection functions and performance data-recording functions. The irregularities of "irregularity detection" (or movement diagnostic) functions are not situations where a fault has occurred, but situations where a temporary logical contradiction may arise from contact-point signals and/or where bad input/output signals may be encountered within the control unit due to deterioration over time, wear and tear and grime. Such irregularities also include situations where even though elevator systems are functioning normally under regular operating conditions, they may not function properly under emergency

conditions, impairing safety and functionality.

By their very nature, it is extremely difficult to track down such irregular conditions during regular on-site inspections. Based on analyses of data gathered over time that identify the course of events preceding malfunctions, model by model, we can now detect such conditions by using an operational diagnostic program using structured logic.

PERFORMANCE DATA-RECORDING FUNCTIONS. Measuring such things as the number of operations and duration of current flows as well as the number of door openings and closings at each floor for the equipment installed, yields information that is vital in drawing up elevator inspection, maintenance and replacement schedules. Through this process, it is possible to identify elevator abnormalities that are on their way to creating breakdowns and to rapidly carry out the appropriate preventive maintenance.

Furthermore, when there is a persistent incidence of irregular data, the elevator transmits irregular signals/data to the call center. Maintenance personnel analyze the reasons for the irregular data received, and then can carry out effective preventive maintenance, implementing action plans based on their analyses.

Since elevators have an important role as a means for vertical transportation within cities, we must maintain their functioning and safety at a high level at all times. For this purpose, in Japan the corporation has set up and is operating a system capable of remote monitoring for more than 200,000 elevators under its management.

Based upon our experience within Japan, we have developed an overseas version of the MIC/Remote Maintenance System. It has already been installed in a number of countries and is producing clearly evident benefits. In view of these results, and in concert with the overseas sales activities of Mitsubishi Electric, from the current fiscal period on the corporation will run a campaign to promote use of this system and to determine its proper positioning, moving ahead to enhance and expand the maintenance activities of affiliated overseas businesses. □

The World's Fastest Elevators

by Satoru Kato and Jun-ichi Higaki*

High-rise buildings are more popular than ever. This trend is driving progress to improve the performance of the elevators that provide vertical transport in tall structures. Shuttle elevators and double-deck elevators have also come into favor. Rising to the challenge, Mitsubishi Electric Corporation has developed both the world's fastest elevator, which travels at an ultra high-speed 1,080m/min, and a high-speed, high-capacity elevator that can carry loads of up to 4,800kg at 600m/min.

Along with the development of high-performance traction motors to hoist and lower the elevator cars and control systems to operate the traction motors, increasing the speed of elevators also entails taking care to ensure that passengers can ride in comfort at extremely high speeds of 1,000m/min. It was also necessary to develop technology to minimize vibration and noise within the cars.

This article shows how new technologies have been implemented in the creation of the world's fastest elevators.

High-Capacity Traction Motors

Mitsubishi Electric usually classifies as high-speed elevators those that travel faster than 120m/min. For this class of elevator we were the first company in the industry to adopt the use of PM (permanent magnet synchronous) motors, which combine excellent efficiency with quiet operation. These days, PM motors have come to be used for nearly all high-speed elevators.

In the case of the ultra high-speed elevators discussed in this article, when the shaft length exceeds 400m, the mass of the hoisting ropes and the car contribute to mechanical inertia, making it too large compared with general elevators. Consequently, to accelerate and decelerate the elevator, we needed a motor that would be able to exert very large torques.

This led to the adoption of a double-winding three-phase design for the PM motor. This winding method involves creating, in a single motor unit, a double coil around the iron core. This tandem method and miniaturization give an excellent structure. Moreover, the independent winding of each coil enables use of twin control systems for parallel-drive control.

Fig. 1 shows both the external view of a traction motor that incorporates a double-winding three-phase motor for high-speed, high-capacity elevator applications, and its control system.



Fig. 1 The traction motor and its control system

Drive-Control System

Fig. 2 shows the configuration of the control system for a high-speed, high-capacity elevator. Parallel drive control is configured so that each of the main circuits is controlled independently and this increases the degree of design freedom for the layout of the control panels. The inverter uses six IGBT (insulated gate bipolar transistor) modules rated at 600A connected in parallel. A single unit of this type of control equipment is able to handle operation of an elevator rated for a speed of 540m/min and a load of 4000kg.

In the parallel control system, the inverter controller has both a single-speed controller and two electrical-current controllers. Control takes into account mutual interference between the two coils of the double-winding three-phase motor. This enables very precise control of traction motor speed and torque, thus ensuring a comfortable ride.

The converter controller maintains a constant DC voltage supply to each part of the drive system. The phase of the power supply voltage is detected, and the power factor of the output current is maintained at 1 (unity) during powered operation and at -1 during regenerative operation.

Vibration-Damping Equipment

Comfort during the running of high-speed eleva-

*Satoru Kato is with Inazawa Works and Jun-ichi Higaki is with the Advanced Technology R&D Center.

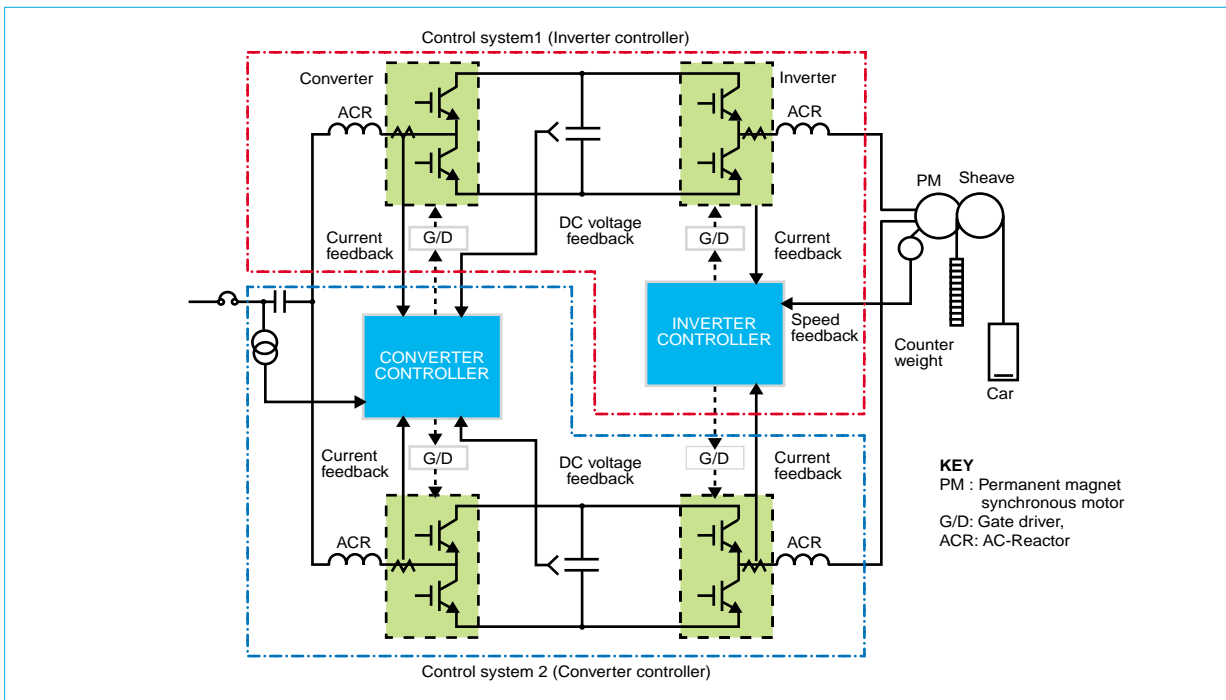

Fig. 2 Configuration of the control system.

tors largely determined by car vibration. When riding inside the car, passengers are particularly sensitive to lateral (horizontal) vibration, which is often experienced as discomfort. Lateral vibration primarily results when deformed or slightly misaligned guide rails generate a perturbing force on the car. The higher the car speed, the higher the perturbations become, thus increasing the strength of vibration.

In the past, to reduce the vibration, oil dampers and other passive devices were introduced to the guide shoe or located between the elevator car and the frame. Additionally, the greatest care is taken to increase the precision of guide rails during machining and to improve alignment accuracy during installation to minimize the perturbing force.

With the prospect of high-speed elevators traveling at more than 1,000m/min, however, there was concern whether these conventional passive-damping systems would be able to adequately control vibration. Moreover, along with increasing technical difficulties, it has become prohibitively expensive to specify more precise machining of guide rails and implement further improvement in alignment accuracy. Consequently, for these high-speed elevators, it was necessary develop new technology for reducing lateral vibration.

As a next-generation vibration damping system for high-speed elevators, the corporation has developed both an active roller-guide system to suppress vibration originating at the guide rail and an active control system installed between

car frame and platform to suppress car vibration by using electromagnetic actuators. A description follows of the active-control system that is installed between car frame and platform specifically designed for high-speed elevators.

Structure of the Active-Control System Between Car Frame and Platform

Fig. 3 is a mimetic diagram of the active-control system that was developed. Actuators are installed under the car floor between the platform and car frame. The actuators reduce vibration inside the car by using accelerative feedback from an accelerometer (sensor) fitted in the car. The actuators make use of electromagnetic attraction. This enables the small device to apply a powerful force. Moreover, because the driving

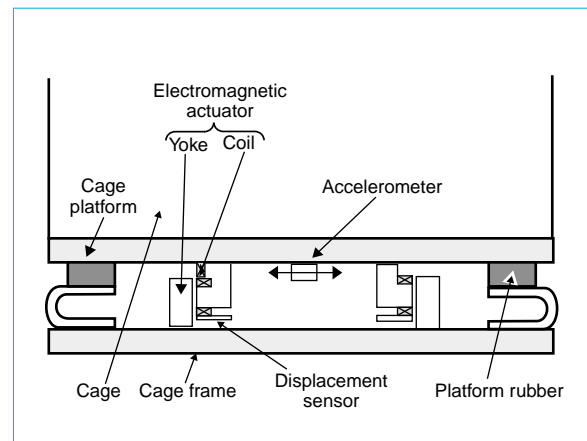

Fig. 3 Active control system under the cage platform.

force does not require contact, the system has the advantage of avoiding the effects of floor sinkage caused by fluctuations in car loading.

Compensation for Non-Linearity

The disadvantage of using an actuator that makes use of electromagnetic attraction as described above is that because of the gap between the coil and the pole, the force of electromagnetic attraction is non-linear. This causes problems with effective control. To deal with this issue, an eddy-current sensor is used in this system to monitor the gap between the coil and pole. Data from the sensor is processed to compensate the current values and linearize the driving force.

Vibration-Suppression Control System

Fig. 4 is a block diagram showing the vibration-suppression control system. The equation used to regulate vibration control is shown below.

$$F_m = - \left[\frac{K_v T_i}{T_i s + 1} + \frac{K_p T_i^2}{(T_i s + 1)^2} \right] G_h(s) G_l(s) \ddot{x}_1 \quad \text{Eq. 1}$$

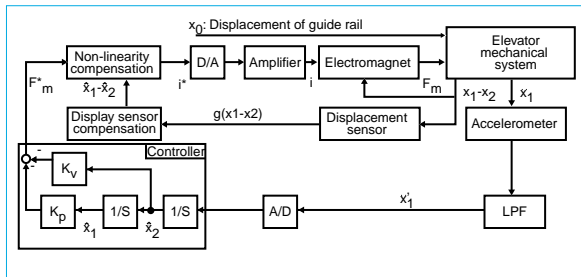

Fig. 4 Block diagram of active control system installed between car frame and platform.

Here, K_v is feedback gain for the acceleration of the car and K_p is feedback gain for the position of the car. By optimizing these, the vibration of the car is suppressed. Furthermore, $G_h(s)$ is a low-cut filter to attenuate the DC component of vibration and $G_l(s)$ is a low-pass filter to reduce high frequency noise from the acceleration sensor.

Results of Trial Operation

Practical trials with an actual test elevator were carried out using the actuators and control equipment described above.

Fig. 5 shows test measurements of X vector (left-right) and Y vector (front and back) motion of the car with and without active-vibration control. It is clear that application of the control effected a 50% reduction in vibration.

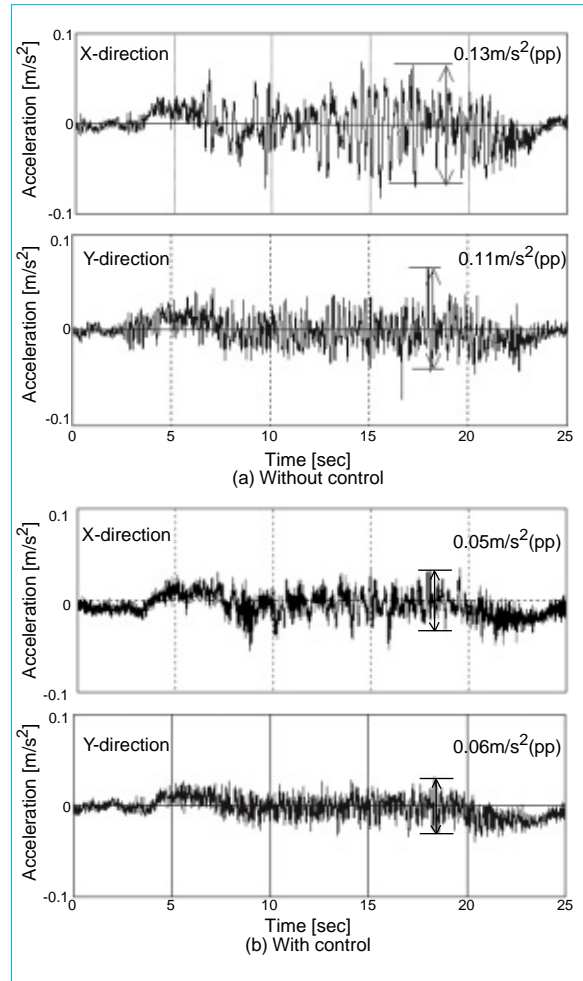

Fig. 5 Test results of floor active control

This concludes our introduction to some of the technology associated with the successful development of the world's fastest high-speed elevator, operating at 1,080m/min. Practical achievement of excellent ride comfort was based both on the expertise that Mitsubishi Electric has accumulated in past development of high-speed elevators and on familiarity with the latest technology. The corporation is committed to meeting the needs of the world for the most advanced forms of vertical transportation. □

Escalators with High-Speed Inclined Sections

by Manabu Ogura and Yasumasa Haruta*

A basic technology has been established for the inclined sections of high-speed escalators capable of increasing the step-moving speed within these sections by 1.5 times the corresponding step-moving speed at the landing sections.

Based on the new technology, a one-fifth scale model (Fig. 1) was fabricated and this confirmed that basic operations such as changing speed, reversing, etc., can be performed without any problems. This is the world's first such scale model.

If high speeds can be achieved in the inclined sections of an escalator, the hitherto irreconcilable aims of securing high safety while getting on or off the escalator and of minimizing the time spent on the moving escalator itself can both be achieved.

Also, if the inclined section is

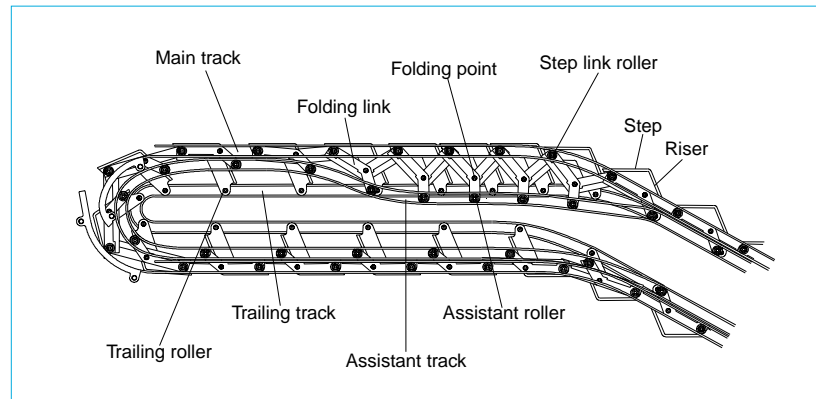

Fig. 2 An expanded view of the upper landing of an escalator with high-speed inclined section

run at normal speed, this can be combined with a slow-running landing section, forming a very safe escalator that is easy on the elderly, children, etc.

The speed is changed by expanding and contracting the folding links that connect adjacent steps using a cam mechanism comprised of rollers and

tracks so as to change the space between the steps (see Fig. 2). For the practical implementation of this mechanism, we are currently evaluating the possibilities by analyzing dynamic simulations of step acceleration during speed changes, drive resistance, etc., and by optimizing the shapes of the cam (track), the precise location of the turning-back (folding) point of the steps, etc.

Issues requiring future work are the development of a variable-speed handrail system and the examination of safety when walking on the steps. □

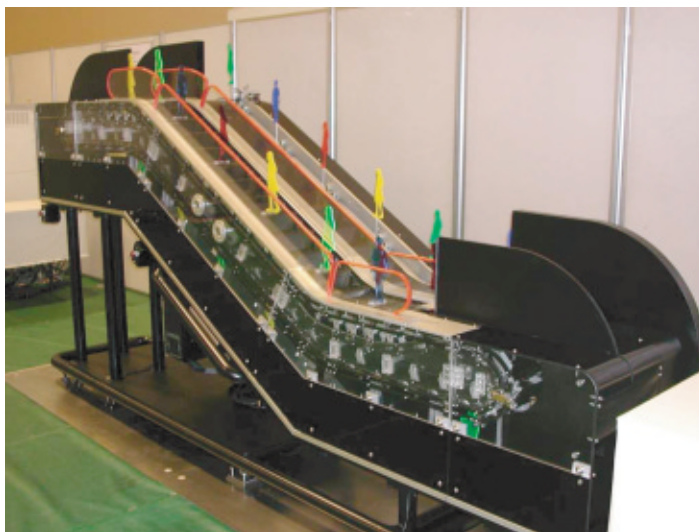

Fig. 1 A one-fifth scale model of an escalator with high-speed inclined section

*Manabu Ogura is with Advanced Technologies R&D Center and Yasumasa Haruta is with Inazawa Works.

Diagnostic & Support Equipment for the Insulation of Traction-Machine Motors

by Teruo Konno and Naoya Yamada*

We have developed insulation evaluation support equipment that analyzes the state of insulation from detailed, conveniently gathered measurement data. This equipment can be built into a support system that enables assessment of deterioration and estimation of remaining service life.

Accumulated data for dielectric breakdown and insulation diagnostics has been built into a database. This allows statistical estimation of the remaining service life.

In the past, it has been customary to rely on meggers (megohm-meters) to measure insulation resistance. In-depth evaluation of insulation called for separately acquired data for DC absorption currents and dielectric loss tangents. This method involved painstaking work and effective assessment required expert analysis, so it was seldom used on site.

As part of a company that has been delivering increasing numbers of traction machines over the past two decades, we set out to develop a system that would enable regular maintenance staff to diagnose the degree of deterioration of insulation in traction-machine motors. This equipment is described below; a photograph is shown as Fig. 1.

First, we list the main specifications of the diagnostic equipment used by the support system.

- Insulation resistance measurement
Range: 0.1~10,000M Ω
Preliminary measurement: at 250V DC (for 1min)
Normal measurement:



Fig. 1 External view of the diagnostic equipment

at 500/1000V DC selectable (for 1min)

- Current measurement
Range: 0.01 μ A~10mA
Measurement voltage: 500/1000V DC selectable
- Dielectric loss tangent measurement
Range: 0.1%~60%, 1~100nF
Measurement voltage: 100~500V AC variable, 50/60Hz.

As well as being able to measure the normal one-minute value for insulation resistance (in Megohms), a more accurate assessment of the characteristics of the insulation material actually used in the motor can be obtained by measuring DC absorption current (attenuation characteristics of leakage current) so as to yield the polarization index (PI: an indicator of the attenuation of DC absorption

current).

Furthermore, the equipment analyzes the AC dielectric loss tangent and shows its voltage dependency.

For more convenient on-site use, the equipment automatically evaluates insulation resistance, followed by current absorption, and then dielectric loss tangent without needing the operator to switch connections. Insulation resistance data is graphically represented on the display panel and recorded on a computer diskette (see Fig. 2).

The insulation evaluation system does more than gather data. Besides on-screen displays of the results of maintenance check data, fuzzy logic is employed to apply to the data the same criteria used by expert technical diagnosticians. Following these diagnostic rules, the state of insulation deterioration (assessed

*Teruo Konno and Naoya Yamada are with Mitsubishi Electric Building Techno-Service Co., Ltd.

Service office	K service office	Date manufactured	Feb. 1973
Type of service contract	MF	Date evaluated	7 Nov. 2000
Control number	11234	Building name	Building A
Machine number	02	Weather	Cloudy
Equipment type	DMN	Temperature	28.0°C
Model number	M G 246 DB	Humidity	67%
Evaluated part	Stator	Environment	Good

Insulation resistance measurements and indicators
 Preliminary measurement at 250V for 60s, 452MΩ
 Normal measurement at 500V for 60s, 463MΩ
 Weak point ratio 1.0

PI Measurement (at 500V, 10min)

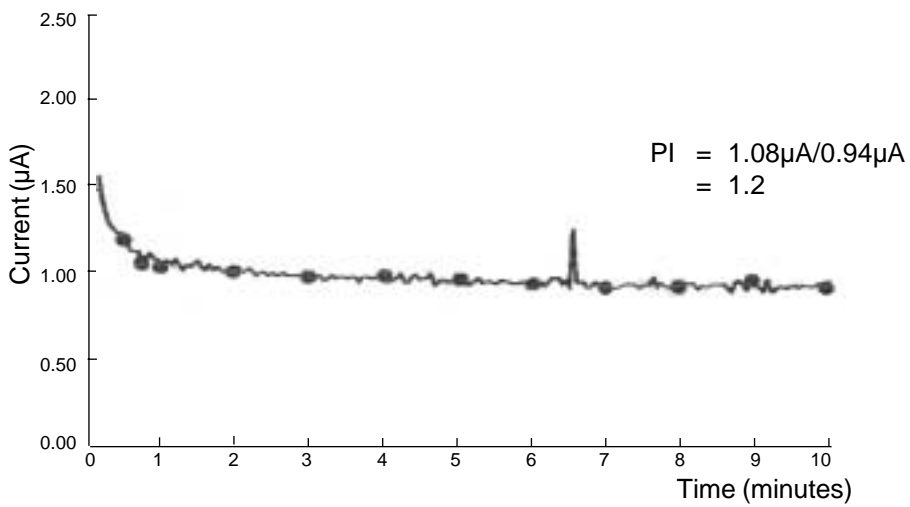

Tan δ Measurement (at 500V)

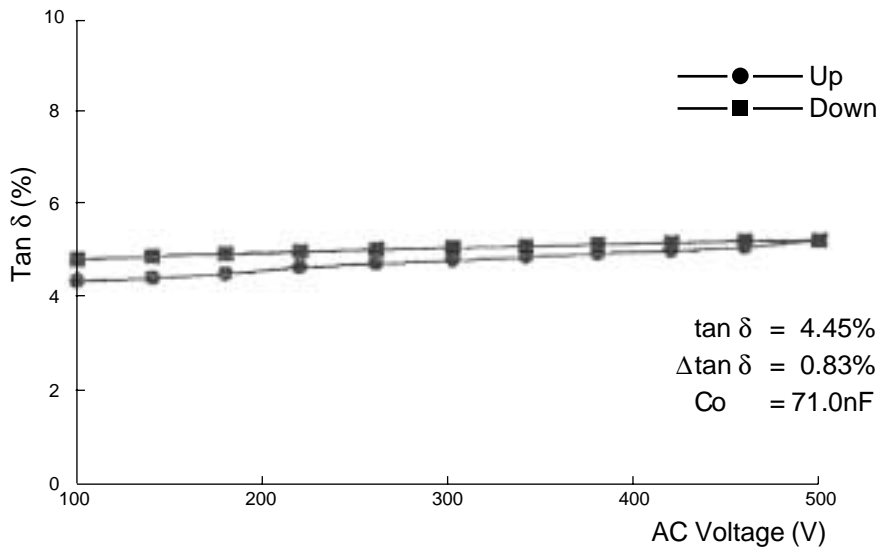

Recommendation

The insulation resistance measurement looks favorable, but taking into account the PI and tan δ measurements, we may infer that contamination has already started and that the presence of voids makes moisture absorption possible.

Fig. 2 Typical insulation measurement results

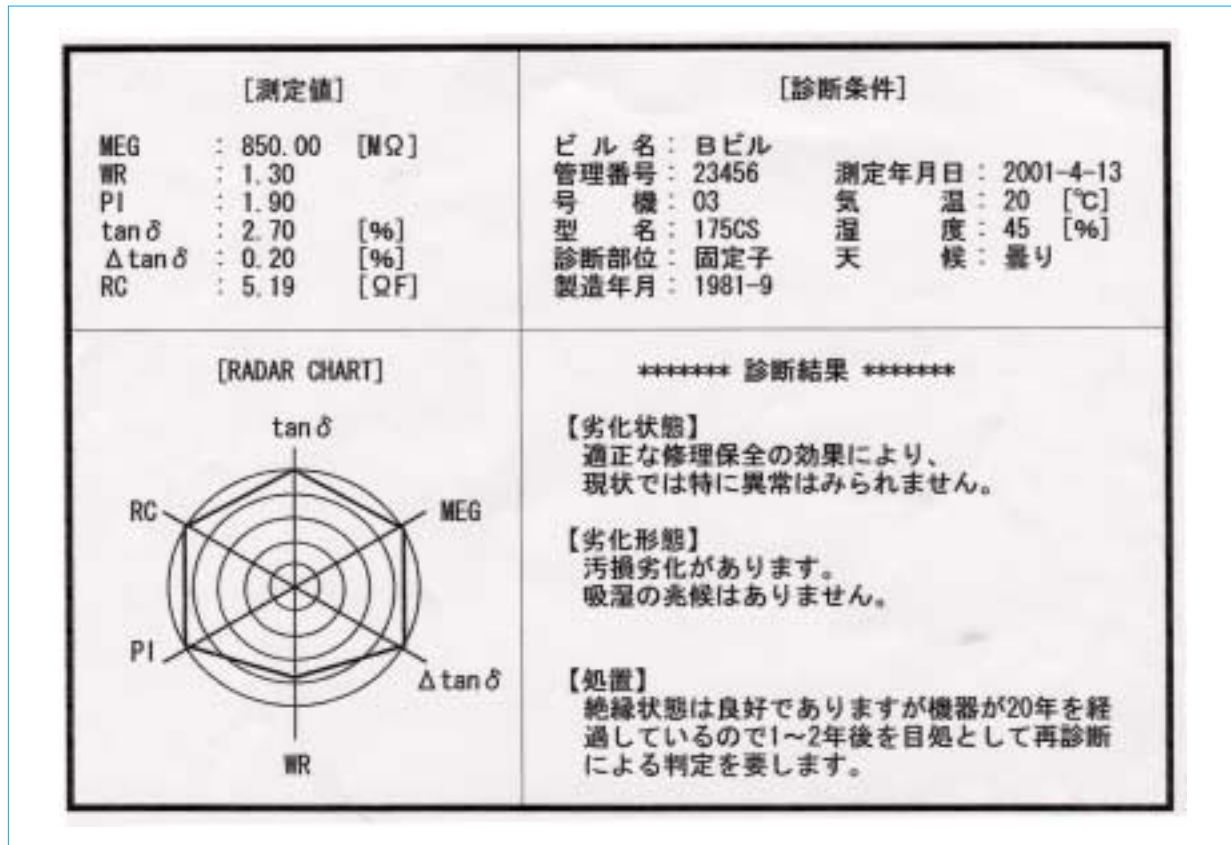

Fig. 3 Typical diagnostic display

grade) can be evaluated (see Fig. 3). Note: This display is only available in Japanese.

To evaluate remaining service life, the system collects and analyzes correlations between 820 measurements concerned with insulation characteristics and 150 for breakdown voltage (BDV).

The system is able to provide an averaged grade for assessed deterioration from the values gathered by the insulation evaluation system. It also reveals comparatively good correlations between the BDV of the armature, stator, field magnet, rotor and other components of the electric motor.

Consequently, using these correlations, regression lines can be derived for each tested component and, from the yielded residual BDV values, an estimate can be made of remaining service life.

Analysis of the deterioration reveals regression lines for de-

terioration and residual BDV to yield 95%, 90%, and 50% reliability assessment grades, thus enabling estimation of remaining service life (see Fig. 4a and 4b).

Based on the lower limit (BDV) breakdown voltage shown in the graph (Fig. 4b), the difference between the present 50% regression line value and the 90% or 95% reliability shows estimated residual BDV.

The results of this system for diagnosing the insulation deterioration of the motors used for elevators provide insight into the state and form of deterioration and they enable technicians to recommend specific courses of action. The results conform well with those obtained by expert technical diagnosticians who use conventional methods. Moreover, we have verified good correlation of results for estimated residual BDV and on-site measurements of BDV.

Table 1 Data and Recommendation for Fig. 4

Building name	Building C
Access number	12345
Machine number	01
Machine type	175CS
Part evaluated	Armature coil
Date manufactured	April 1980
Date evaluated	April 2001
Number of indicator	6
Rated voltage	220V
Days in use	7,668
Residual breakdown voltages	
50% reliability	2,573V
90% reliability	595V
95% reliability	198V
Estimated remaining service life	
50% reliability	5.5 years (2,010 days)
90% reliability	3.0 years (1,105 days)
95% reliability	1.4 years (494 days)
Recommendation	
The results of remaining life assessment suggest that this motor is approaching the end of its service life. Deterioration in the insulation as a result of ageing suggests that the motor should be replaced within the next year or two.	

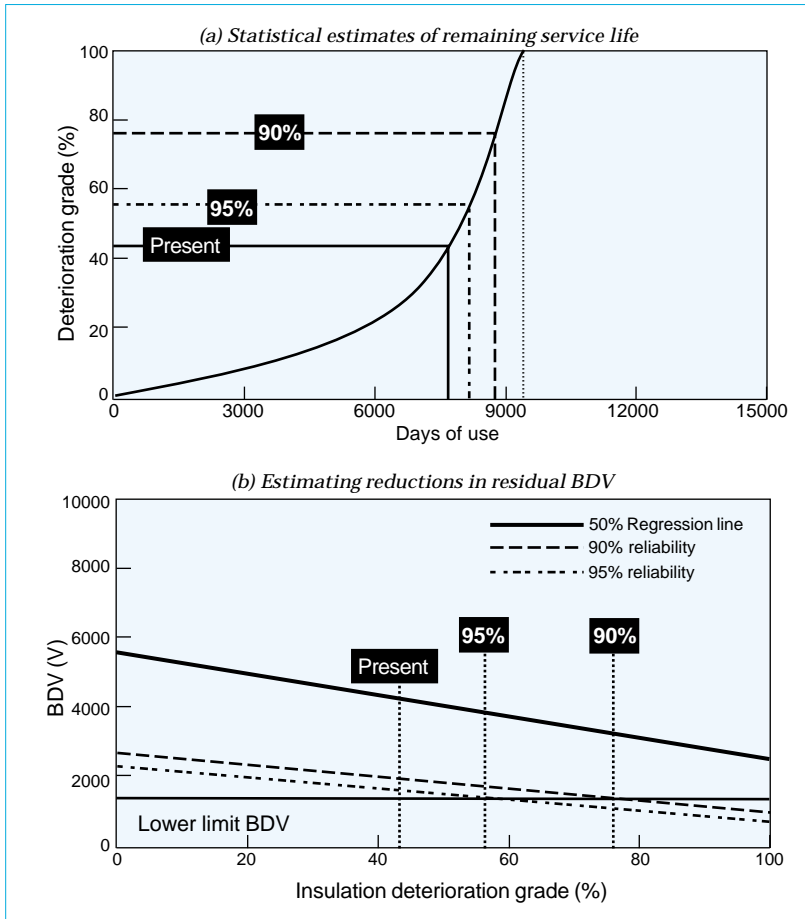

Fig. 4 Typical displays for estimated remaining service life

As this insulation diagnostic equipment and insulation evaluation support system goes into more widespread use, its efficacy will be further proved, leading to still further applications. This will help to ensure the reliable operation of rotary motors and aid customer to appropriately schedule the necessary repairs and preemptive replacements. □

NEW PRODUCTS

MELART-II; New Full-Color Paint Finish

In December, 1995, Mitsubishi Electric created a precedent in the industry by introducing the use of computer graphics for painted steel elevator panels. These MELART panels have provided elevators with distinctive finishes ever since. However, increasingly diversified building designs and the role of elevators as the main portals by which people enter buildings have given rise to demand for even more individualistic and original, better-crafted designs.

In response, the corporation has made fundamental changes to the previous method of producing MELART panels, increasing the graphic resolution for these large panels from 400dpi to 720dpi. Improvements have also been made to the light-resistance of the finish, and MELART II options now extend to gloss and semi-gloss (or matte) full-color finishes.

The new panels use a special printing process to create thermo-setting films of paint combined with technology to ensure that these films can be "baked" onto the metal

surfaces, creating full-color steel panels. This avoids the need for plate making as in silk-screen printing, and is ideal for short production runs of many variants.

The technology for these painted finishes is proprietary, and the sub-

ject of pending patent applications. It also has many potential applications beyond elevator panels. MELART II panels have the following characteristics:

MELART-II reproduces beautifully and with complete fidelity and stability traditional Japanese paintings, geometrical figures created by silk screen printing, and graphic illustrations.

Well-suited for small-lot production of many product variants, MELART-II also has the clear advantage of undergoing only half the fading of automobile finish coatings under exposure to ultraviolet radiation. □

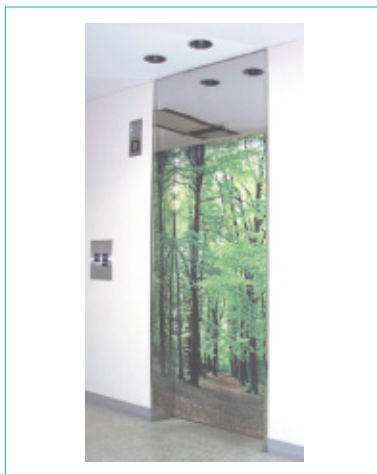

Fig. 1 An elevator door showing the beautiful color finish possible with MELART II.

New Home Elevators

Since starting to manufacture home elevators (private residence elevators) in 1988, Mitsubishi Electric has installed an impressive number of these units: over 16,000 within Japan and hundreds overseas. The corporation's new home elevators meet the demand for high-speed drives, which is particularly strong in overseas markets.

The large buttons on the car-operating panel provide easy-to-use control and the machinery itself has been downsized and lightened, making home elevators as easy on the environment as they are easy to use. A typical car design is shown in Fig. 1.

The basic (standard) specifications are for three passengers, stopping at up to four floors (rise to be 10m or less), with decorated steel panels providing both rigidity and high quality for the car and doors. Ventilation fans, mirrors, handrails and dual openings are available. The compact designs make minimal requirements for space: installation is possible in a space only 1.5m wide by 1.5m deep (a special machinery room is unnecessary).

The features of the new elevators are as follows:

Speed has been increased from the previous 12m/min to 20m/min, shortening operation time to 60%. Although the rated speed has been increased 1.7 times, the development of low-noise motors, a new winding machine and an improved controller means that vibration and noise characteristics are comparable with the previous elevators.

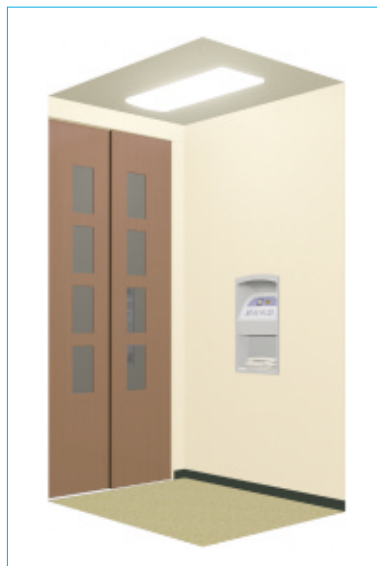

Fig. 1 A typical car design

The Mitsubishi emergency landing device (MELD) system for power failure is supplied with batteries and a charger as standard. Owners can therefore feel safe in using these elevators.

Single-phase 200V AC power is required, but different voltages can be accommodated in individual designs within the range 210 to 240V AC.

Installation of these home elevators is easier and can be completed faster than for previous elevators thanks to the adoption of the front-rail installation system. In this system, the guide rails are installed on the front-entrance side of the elevator shaft wall by means of brackets, after which the entrance units are mounted on the guide rails. □

