

VOL. 79/JUN. 1997

mitsubishi electric

ADVANCE

Iron and Steel Plant Electrical Equipment Edition

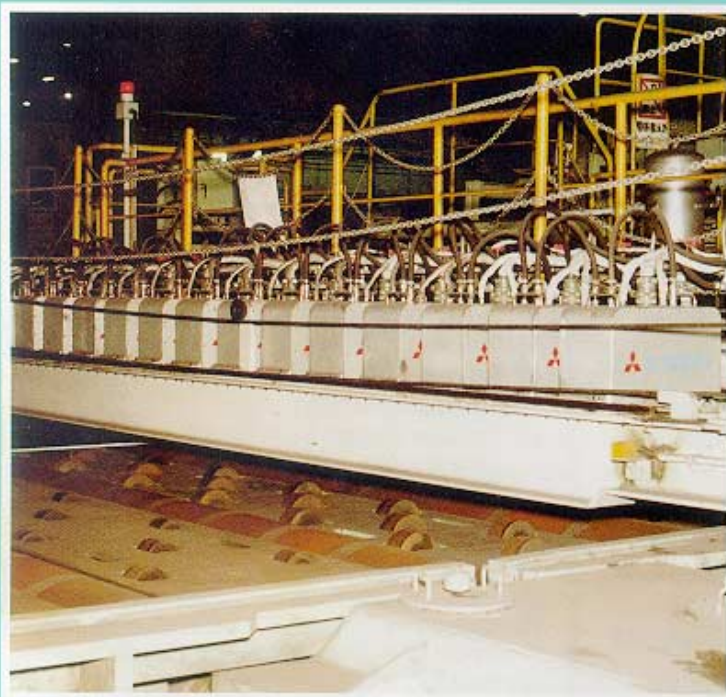

Iron and Steel Plant Electrical Equipment Edition

CONTENTS

TECHNICAL REPORTS

OVERVIEW

The Present and Future Prospects for Electrical Equipment in Iron and Steel Plants 1
by Shuuhei Niino

Advanced Electrical Equipment for Hot-Rolling Mills 2
by Kazunobu Takami and Yoshiaki Nakagawa

Electrical Equipment for Steel Processing Lines 5
by Seiji Takayanagi and Shigeharu Hamada

Motor-Drive Systems for Steel Rolling Mills 8
by Yuji Sano and Ichiro Serikawa

An Industrial Computer System for Iron and Steel Plants 11
by Kazuo Sena and Noriyoshi Hiratsuka

A Control System for Steel Mills 15
by Mitsunori Hirayama and Nobuchika Furusawa

A Control Model Analysis Support System for Steel Mills 18
by Naoki Shimoda and Yoshinori Wakamiya

Developments in Welders and Induction Heaters for Steel Plants 21
by Toshinobu Eguchi and Keiji Sodeno

R&D PROGRESS REPORT

A Novel Regenerative Snubber Circuit for Three-Level GTO Inverters 24
by Hideo Okayama and Taichiro Tsuchiya

TECHNICAL HIGHLIGHTS

Profile Sensors for Iron and Steel Plants 27
by Katsuya Ueki and Masayuki Sugiyama

A New Database Architecture for Generalized Object Tracking 29
by Hideyuki Takada and Joji Ido

NEW PRODUCTS 31

NEW TECHNOLOGIES 32

MITSUBISHI ELECTRIC OVERSEAS NETWORK

Our cover shows four systems with critical roles to play in the iron and steel industry: a Series MR3000 industrial computer (upper L); a flatness meter (lower L); a large capacity GTO inverter system (upper R); and the MELPLAC-750 electrical and instrument controller with OPS750 (lower R).

Editor-in-Chief

Akira Yamamoto

Editorial Advisors

Jozo Nagata
Toshimasa Uji
Tsuyoshi Uesugi
Satoru Isoda
Masao Hataya
Gunshiro Suzuki
Hiroshi Shimomura
Hiroaki Kawachi
Akihiko Naito
Nobuo Yamamoto
Shingo Maeda
Toshikazu Saita
Hiroshi Tottori
Kouji Kadota

Vol. 79 Feature Articles Editor

Fumio Yoshida

Editorial Inquiries

Kouji Kadota
Planning and Administration Dept.
Corporate Engineering, Manufacturing &
Information Systems
Mitsubishi Electric Corporation
2-3-3 Marunouchi
Chiyoda-ku, Tokyo 100, Japan
Fax 03-3218-2465

Product Inquiries

Tsuyoshi Uesugi
Strategic Marketing Dept.
Global Operations Group
Mitsubishi Electric Corporation
2-2-3 Marunouchi
Chiyoda-ku, Tokyo 100, Japan
Fax 03-3218-3597

Orders:

Four issues: ¥6,000
(postage and tax not included)
Ohm-sha Co., Ltd.
1 Kanda Nishiki-cho 3-chome
Chiyoda-ku, Tokyo 101, Japan

Mitsubishi Electric Advance is published quarterly (in March, June, September, and December) by Mitsubishi Electric Corporation. Copyright © 1997 by Mitsubishi Electric Corporation; all rights reserved. Printed in Japan.

OVERVIEW

The Present and Future Prospects for Electrical Equipment in Iron and Steel Plants

*by Shuuhei Niino**



Iron and steel plants have always played a leading role in the development and introduction of new industrial technologies. A number of pioneering process innovations have now reached the stage of practical implementation. These include world “firsts” such as continuous casting strip mills, which link the caster directly with the hot strip process, and continuous hot-rolling mills in which strips are welded together to form an endless rolling process. Work is proceeding actively on technologies for mini-mills and inline strip processes (ISPs) to reduce the size of installations, and on CALS research (which in the context of iron and steel plants means both commerce at light speed and continuous acquisition and life cycle support) to reduce engineering and procurement costs.

Electrical products are responsible for performing supervision, measurement and control functions in iron and steel plants, and thus have a central role to play not only in plant operation but also in ensuring that the latest technologies can be adopted and product quality improved.

Recent Mitsubishi Electric products for iron and steel plants are characterized by fast, highly compatible control systems with sophisticated functions. Sensitive and accurate sensors and advanced control techniques are playing their part in fully automated processes, where integrated electrical, instrumentation and computer (EIC) environments that monitor and control operations are improving product quality. Clean, environmentally friendly sources of electrical power, with power factors of unity and minimal high-order harmonic current, are being supplied, as are AC main drive systems that are largely maintenance free and provide high-speed response thanks to the adoption of gate turn-off thyristor (GTO) inverters. □

**Shuuhei Niino is with the Power & Industrial Systems Center.*

Advanced Electrical Equipment for Hot-Rolling Mills

by Kazunobu Takami and Yoshiaki Nakagawa*

Hot-rolling mills play a central role in industrial steel production and require advanced technologies for both large-scale rolling equipment and control systems. This report introduces recent electrical systems for hot-rolling mills and methods for plant modernization.

Drive Systems

Table 1 lists some deliveries of inverters, produced using the world's largest GTO thyristors (6-inch diameter), for hot-rolling mills and plate mills. The following plants have converted entirely to AC drive systems: Bao Shan Iron &

Table 1 Deliveries of Six-Inch GTO Thyristor Inverters

Customer	Application	Hot Run
Baoshan Steel No. 2 Hot-Strip Mill (China)	Sizing press, rougher mill, finisher mill	'96
Sumitomo Metal Wakayama Hot-Strip Mill (Japan)	Rougher mill	'96
Posco Pohang No. 2 Hot-Strip Mill (South Korea)	Rougher mill	'96
Posco Kwangyang Thin Slab Hot-Strip Mill (South Korea)	Finisher Mill	'96
Hanbo Steel No. 2 Hot-Strip Mill (South Korea)	Sizing press, rougher mill, finisher mill	'96
Unnamed hot-strip mill	Rougher mill, finisher mill	'96
Posco Pohang No. 3 Plate Mill (South Korea)	Edger, finisher mill	'97
Posco Pohang No. 1 Hot-Strip Mill (South Korea)	Finisher mill	'97

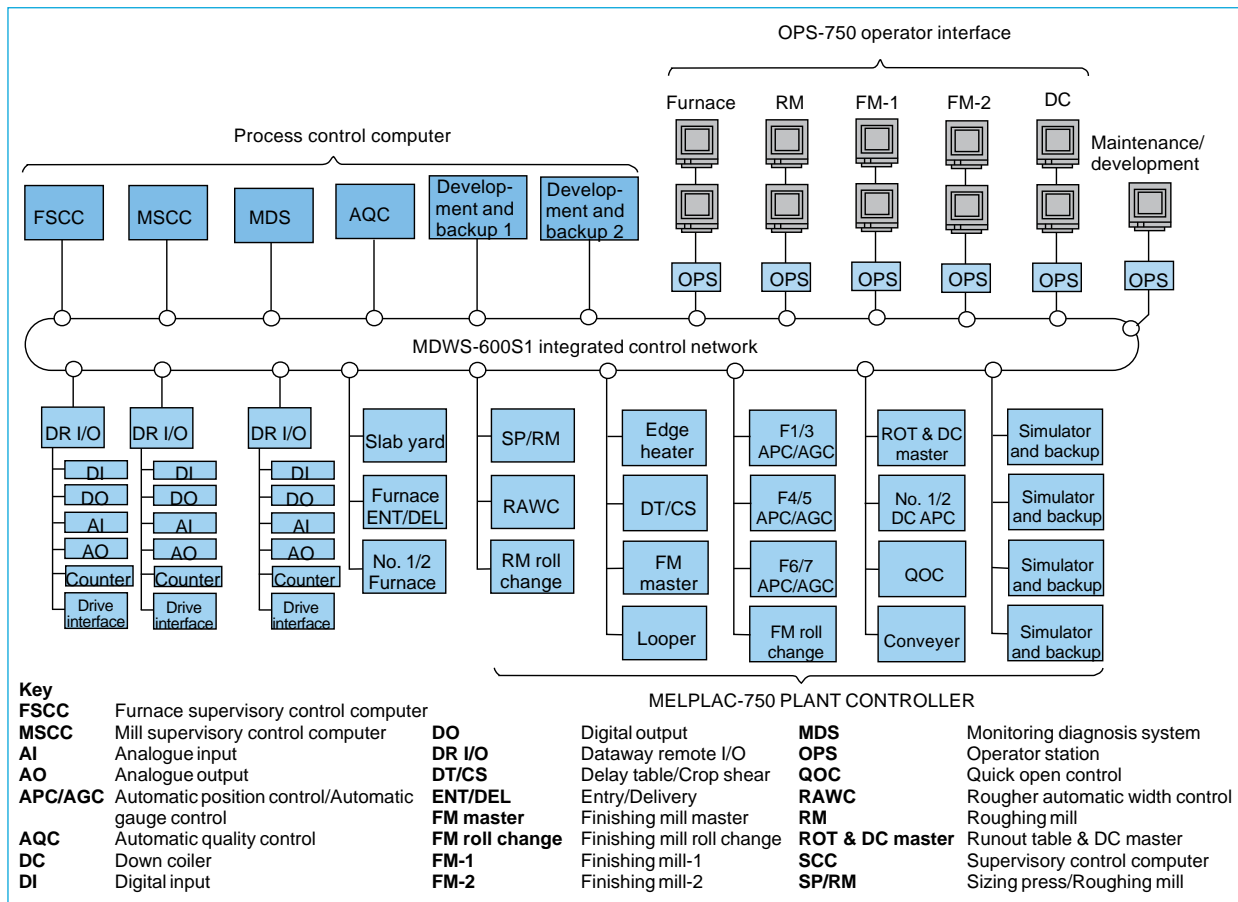

Fig. 1 Control system configuration.

*Kazunobu Takami and Yoshiaki Nakagawa are with the Power @ Industrial Systems Center.

Steel Corporation's No. 2 hot-strip mill (China), Posco Corporation's No. 1 thin slab hot-strip mill and Handbo Steel Corporation's No. 2 hot-strip mill (South Korea), and Yiehloong Corporation's hot-strip mill (Taiwan).

Control Systems

Fig. 1 shows a configuration of the newest control system for state-of-the-art hot-rolling mills. The system consists of an industrial computer system for process control, the MELPLAC-750 controller, man-machine interface, dataway remote I/O units and networking equipment. The following paragraphs list major system features.

A high-speed, large-capacity integrated network system provides 100Mbps and 32Kword capacity, allowing the integration of previously separate dataways for the industrial process control computer, direct digital controllers (DDCs) and a monitoring system. User consoles

for the process control computer and DDCs have been combined with increased data sharing.

A high-speed, large-capacity DDC features 0.2µs/bit arithmetic, a 64K-step program memory and 128Kword data memory. This enables the number of CPU modules to be reduced by a factor of five and the number of cards per CPU module to be reduced by a factor of four.

All process control signals are input or output via dataway remote I/O units which are connected with an integrated network (MDWS-600S1). Process signals can be shared and controller backup is simplified.

Integration of the operator consoles for the process control computer and DDCs permits a unified approach to system control. The control desk has been simplified and the number of operators reduced through use of touch-screen CRT monitors.

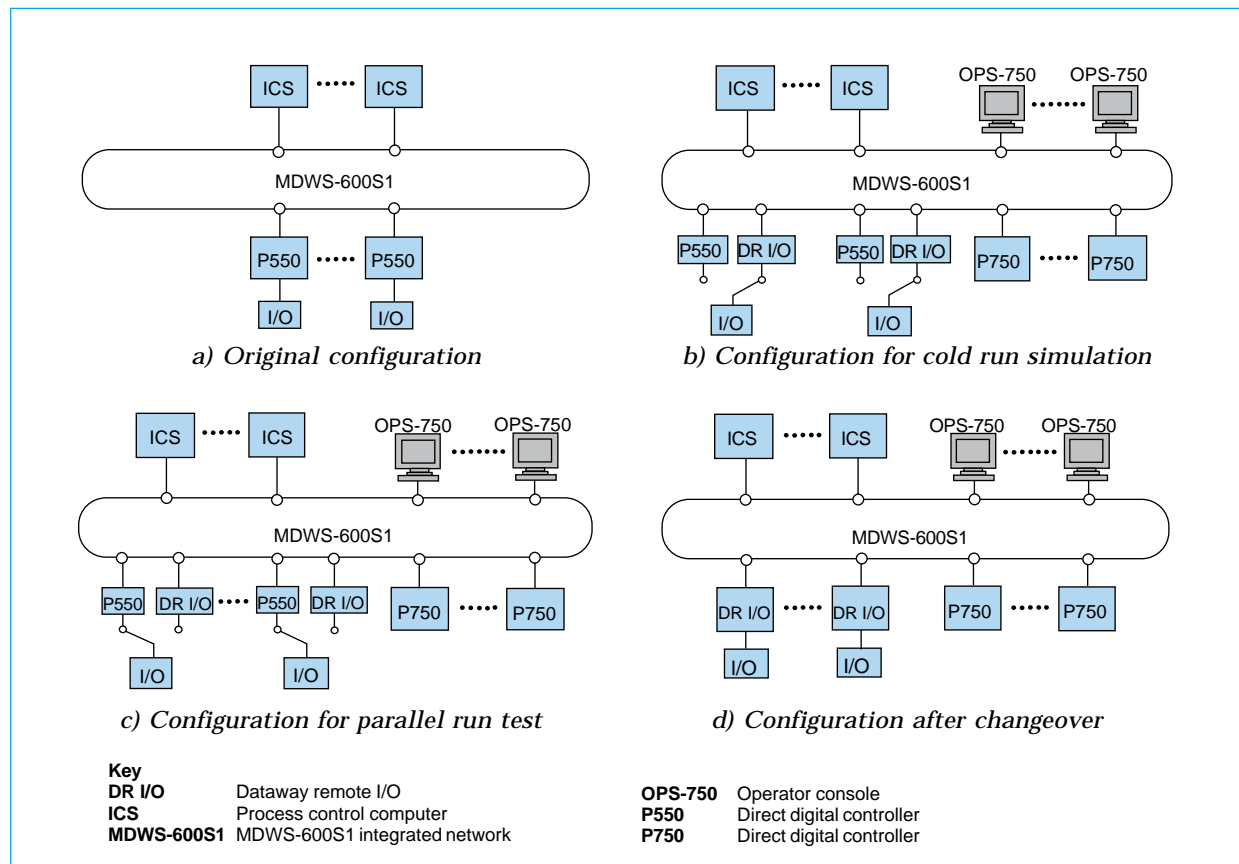

Fig. 2 Modernization procedure.

Modernization of Existing Plants

Modernization is conducted during regular line stoppages so that it can proceed without impacting productivity. A parallel adjustment system allows the new system to be adjusted while the old system is in operation. This facilitates the changeover and reduces the time required to bring the new system into service. The rest of this section describes the modernization of a typical hot-rolling mill.

The modernization consists of replacing all DDCs (replacing MELPLAC-550 with MELPLAC-750), installing the operator console (the OPS-750 with electric, instrument and computer (EIC) integration) with touch-screen CRT monitors, building a more compact operation desk in the operator's pulpit and converting process I/O units to dataway remote I/O units.

Fig. 2 illustrates the changeover procedure, which is designed to make migration as smooth as possible. The existing MELPLAC unit is upgraded to support dataway remote I/O, so that existing process I/O and its cabling can be used and new cabling kept to a minimum. The previous controller software is automatically translated for use in the new controller, allowing continued use with minimum changes.

During short, regularly scheduled line stoppages, we switch over to the new system and perform a "cold-run simulation" (Fig. 2b). To reduce the switchover time, a dataway remote I/O controller is installed in the existing MELPLAC system and the existing programmable logic controller (PLC) is set to switch over to dataway remote I/O with operation of a single button.

Fig. 2c illustrates a parallel run test. While the existing controller is operating the mill, the new controller is connected to the dataway and adjusted. The commands sent from the process control computer to the existing controller are sent to the new controller as well. Further, interfaces between the existing controller and the dataway are set up so that the signals received by the existing controller are transmitted to the new controller as well.

Strip Thickness Accuracy Improvement

Mill modernization provides an opportunity for improving product quality by enhancing control capabilities. The introduction of absolute and high-speed monitor automatic gauge controls (AGCs) dramatically raises the strip thickness accuracy by reducing the strip top-end off-gauge length, which is caused by setup error.

Mitsubishi Electric is the first manufacturer to introduce six-inch GTO thyristor rolling-mill drive and control systems. By considering future expansion, it's possible to conduct time-efficient upgrading with smooth setup and improved strip thickness accuracy. □

Electrical Equipment for Steel Processing Lines

by Seiji Takayanagi and Shigeharu Hamada*

Capacity and performance requirements on electrical equipment for steel processing lines have increased in response to development of large, high-performance lines and high-value-added production. This article provides an overview of electrical equipment Mitsubishi Electric has designed and manufactured to meet these needs.

Drive Systems

Variable-speed AC motor drive systems have brought a number of improvements to steel processing lines. First, AC motors do not require the regular maintenance that DC motors

need. This is especially significant, since many of the motors in steel processing lines are in high places or other locations with limited access. Second, independent speed control for motors in lines with numerous helper rollers enables finer coordination of these rollers than is possible using multiple DC motors under a common thyristor-controlled power supply. Third, in an AC system, rollers for motoring and dragging can be connected to a common thyristor converter allowing exchange of DC power, and with that, the use of smaller-capacity power supplies than in DC motor systems. Finally, Mitsubishi Electric has developed and

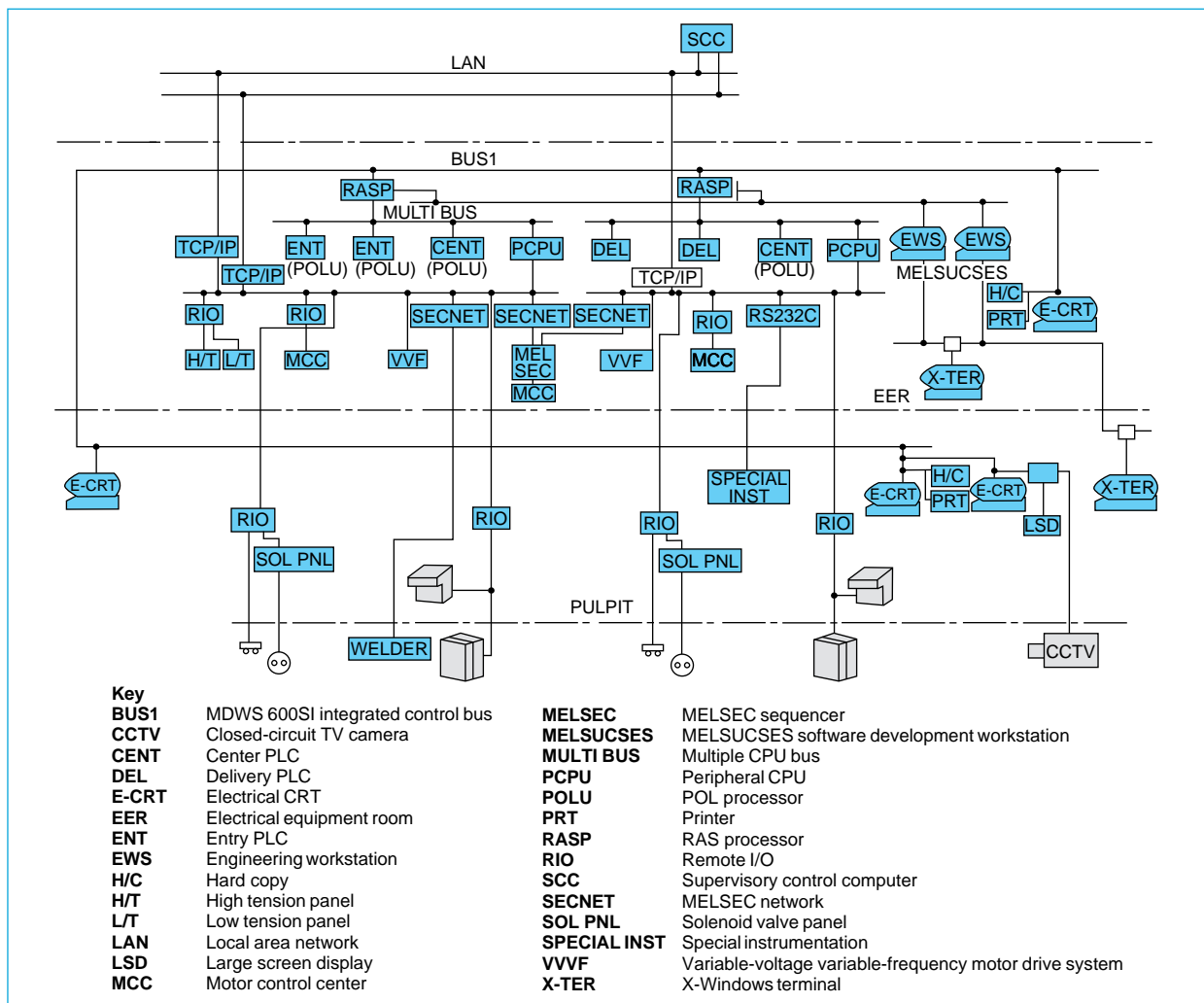

Fig. 1 Control system configuration.

*Seiji Takayanagi and Shigeharu Hamada are with the Power & Industrial Systems Center.

proven a sensorless vector control system for helper rollers that dramatically simplifies larger systems where 200 to 300 helper rollers are used.

Control Systems

The need for faster processing lines with better quality product and less labor-intensive operation translates into demand for faster, more sophisticated and more extensive control systems. Mitsubishi Electric's MELPLAC-750 plant controller meets these needs by combining electrical and instrumentation control functions, and offering high-speed sequence control, advanced arithmetic control, feedback control and batch control capabilities.

Fig. 1 shows the configuration of a state-of-the-art steel processing line based on the MELPLAC-750 plant controller. The system features high-speed RISC processors and dedicated control processors, remote I/O stations that minimize wiring requirements for process I/O, encapsulated software components that facilitate software reuse and support online software component maintenance, and extensive self-diagnostic functions for improved reliability.

The corporation is also offering the MELSUC-

SES workstation which supports MELPLAC-750 software development and maintenance. MELSUCSES allows users to automatically generate control software using the Macro Control Diagram (MCD) control specification language. It has database capabilities that provide a central repository for storing equipment lists and other data on plant facilities. The user can incorporate monitoring functions into MCD programs that allow MELSUCSES to serve as a plant monitoring tool. Finally, the system supports standard software packages that can dramatically reduce software design time.

Demand for faster production of higher quality products is accompanied by competing demand for labor savings that requires development of more sophisticated operator consoles. The Mitsubishi Electric OPS-750 realizes the high-speed response and other performance improvements needed to manage large steel-processing facilities. The OPS-750 has been designed to work with the corporation's LVP 70" video projector, allowing the OPS-750 to display multiple data and control screens and video signals from the plant's CCTV systems on a single large screen. The

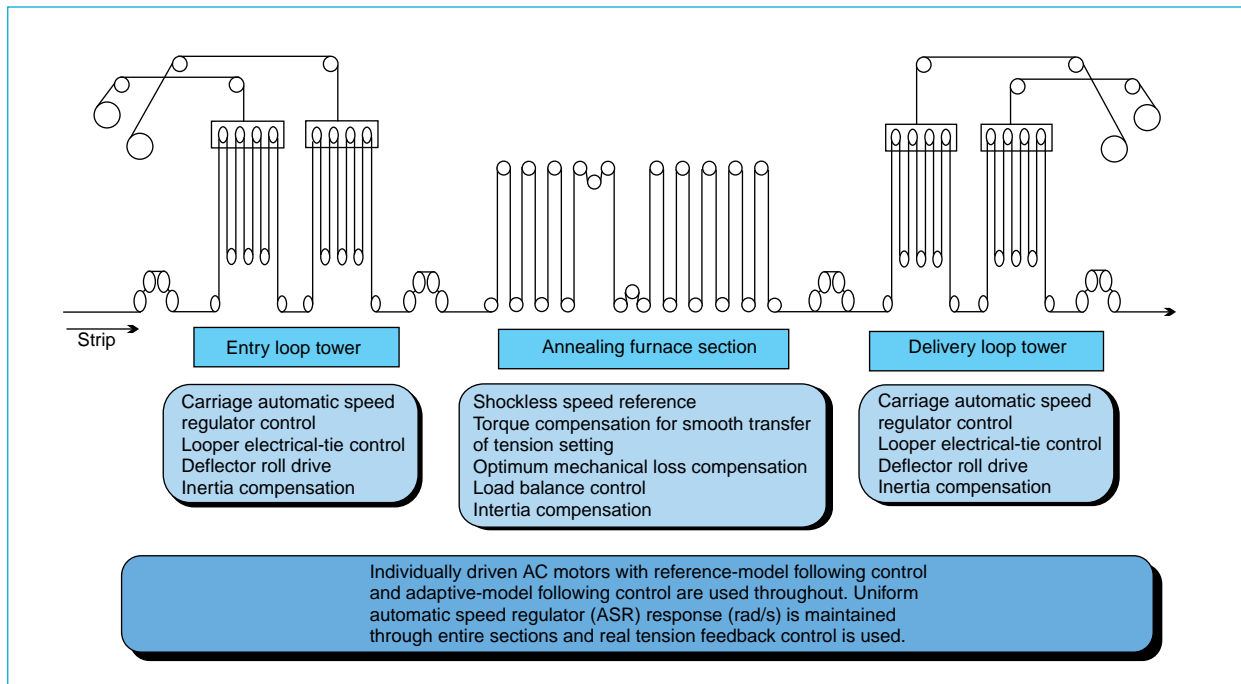

Fig. 2 Strip tension control functions.

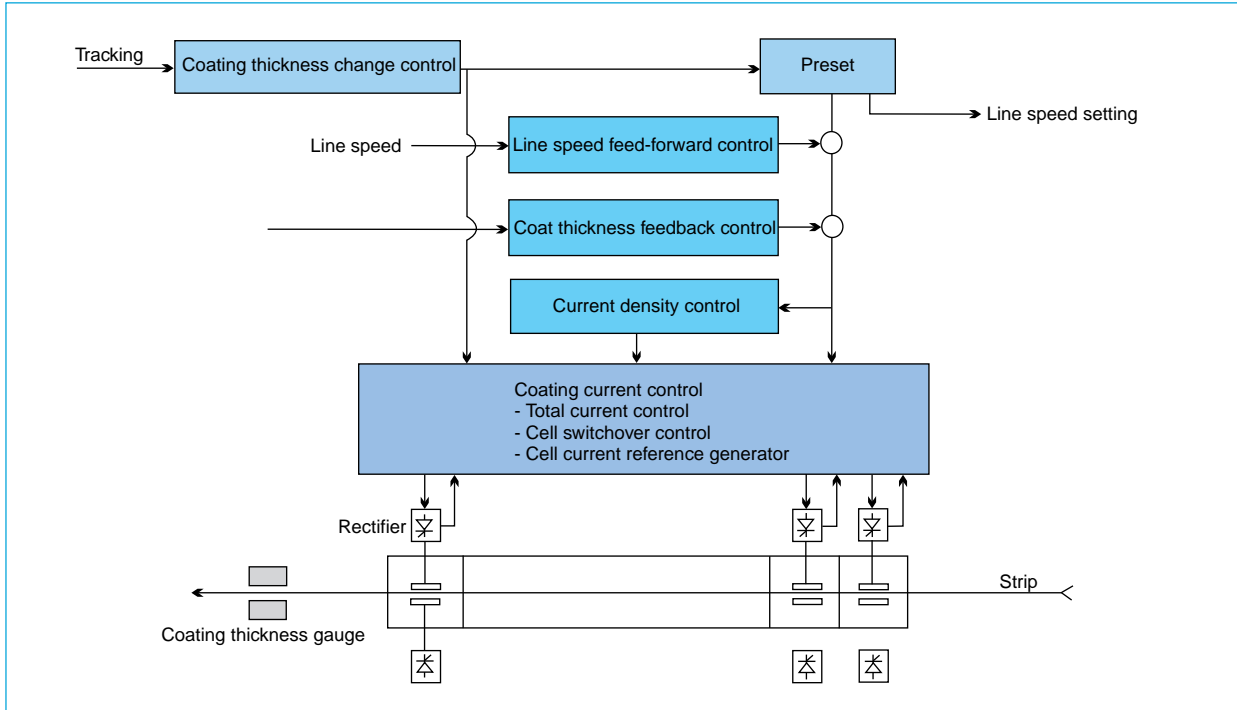

Fig. 3 Coating thickness control system for electrolytic galvanizing or tinning lines.

OPS-750 also supports control screens for individual plant equipment such as welders and coil marking machines, allowing this equipment to be operated from a single OPS-750 console.

Control Technology

Precise control of the strip tension in annealing furnaces greatly influences product quality. Mitsubishi Electric has developed a reference-model following control system to prevent strip tension fluctuations during line speed changes from reaching the critical central area of the annealing furnace. Tension control at the loop towers at the annealing furnace entry and delivery sides prevents strip tension fluctuations originating in welding and shearing operations from being transmitted to the central area.

Fig. 2 illustrates these control functions. The functions permit accurate tension control (within 25kg) in a low-tension application with 0.24mm sheet under a tension of 250kg at speeds as high as 800m/min.

Figs. 3 and 4 illustrate plating thickness control systems for electrolytic galvanizing and tin-

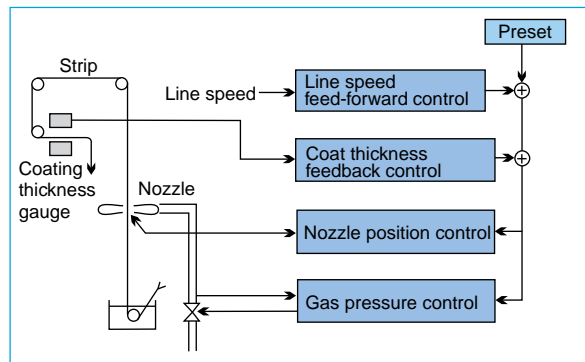

Fig. 4 Coating thickness control system for a continuous galvanizing line.

ning lines and continuous galvanizing lines. Uniform plating thickness is a key measure of product quality.

By rationalizing and centralizing the control of steel processing lines, the equipment presented in this article helps to simplify line operation, boost product quality and reduce maintenance requirements. It is a tribute to the sophistication of modern control technology that these aims can be achieved in parallel. □

Motor-Drive Systems for Steel Rolling Mills

by Yuji Sano and Ichiro Serikawa*

Improvements in high-power gate-turn-off thyristors (GTOs) and insulated-gate bipolar transistors (IGBTs) along with better electric motors and control technology have allowed development of a wide range of voltage-controlled inverter drive systems for main and auxiliary motors in steel rolling mills. This article introduces key elements of these drive systems, including GTO and IGBT inverters, and main and auxiliary motors.

Variable-Speed AC Drive Units

The diagram in Fig. 1 shows the target application spectrum of several variable-speed AC drive

systems. Two-level IGBT inverters are suitable for capacities up to 800kVA, three-level IGBT inverters up to 3,000kVA, and three-level GTO inverters can handle up to 20,000kVA. GTO inverters have already been proven in main motor-drive applications of 6,000kW with a 225% overload capacity, and are currently being tested in 10,000kW applications.

Table 1 lists the specifications of the inverter units. In small- and medium-capacity two- and three-level IGBT applications, a thyristor converter distributes DC power, allowing a single converter to be shared among multiple motors, which lowers system capacity requirements.

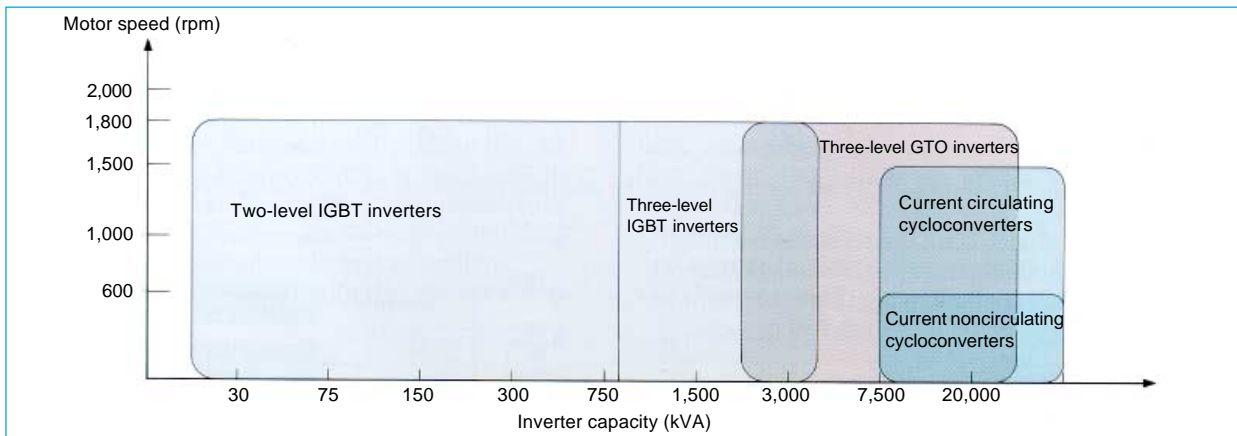

Fig. 1 Inverter types and their motor-drive applications.

Table 1 Inverter Specifications

Item	Two-level IGBT	Three-level IGBT	Three-level GTO
Input voltage	300V/600V	1,220V	2,100V/3,300V
Output voltage	210V/420V	840V	2,400V/3,600V
Output frequency	Approx. 90Hz	Approx. 60Hz	Approx. 60Hz
Speed accuracy	0.01%	0.01%	0.01%
Speed control range	0.5 - 100%	0.5 - 100%	0 - 100%
Speed control response	60 rad/s	60 rad/s	60 rad/s
Current control response	500 rad/s	800 rad/s	600 rad/s
Field weakening range	1:5	1:5	1:5
Torque ripple	0 - 1%	0 - 0.5%	0 - 0.5%
Power-supply power factor	0.74	0.74	0.98 - 1.0
Cooling	Forced air	Forced air	Water

*Yuji Sano and Ichiro Serikawa are with the Nagasaki Works.



Fig. 2 The main circuit of a GTO inverter.

Three-level GTO inverters for large-capacity applications employ a high-power-factor inverter on the input side that reduces harmonic energy and reactive power, thereby improving the power-supply environment.

GTO Inverters

Main motors for rolling mills have previously used cycloconverter drive systems. GTO inverters are now taking over applications from 4,000 to 20,000kVA due to the development of six-inch devices rated at 6kV and 6kA and four-inch devices rated at 4.5kV and 4kA.

Fig. 2 shows a photo of the main circuit equipment. The converter and inverter are combined, and identical main circuit units are used for each phase, facilitating maintenance. The equipment size has been reduced through use of water cooling.

IGBT Inverters

IGBT inverters are configured as two-level circuits for capacities under 800kVA and three-level circuits for capacities of 800 - 3,000kVA. IGBT inverters are efficient and compact due to the IGBT's voltage-driven gate, which allows the use of a small gate amplifier.

Two-level IGBT inverters are available with 200 and 400V output voltages. Both two- and three-level IGBT inverters employ DC power distribution, which allows more compact construction.

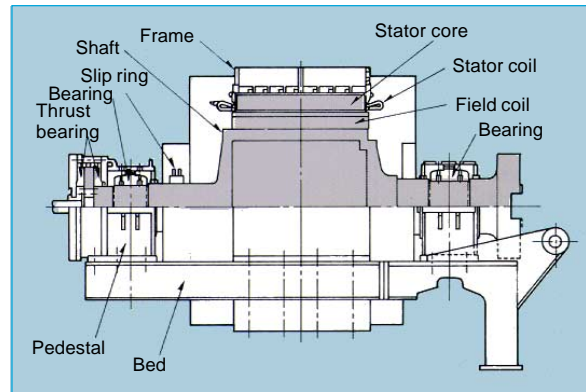

Fig. 3 Cross section of a synchronous motor for rolling mills.

Variable-Speed Synchronous Motors for Steel Rolling Mills

Synchronous motors can be operated with a power factor of unity, have a lower power-source capacity than induction motors, and are relatively small and lightweight. Motors for rolling mills require substantial electrical overload capacity and the mechanical strength to endure the large shock torques that are generated when slab is between rollers. Fig. 3 shows the construction of a reversing synchronous motor for rolling mill applications.

STATOR COIL. To provide the strength needed to withstand rolling shocks, the stator coil and core are integrated, and then a vacuum pressured impregnation process is used to draw in epoxy resin insulation to form a durable coil assembly.

ROTOR. Synchronous motors can have rotors of salient pole or cylindrical construction. Salient pole rotors are used in this application to provide a larger thermal capacity for energy dissipated in the damper windings. Damper windings attenuate transients that accompany the shock that occurs when slab is fed into the rollers.

FIELD COILS. These must be constructed to withstand thermal elongation in the axial direction. A coil brace between field coils helps the assembly withstand centrifugal forces and shocks.

Table 2 TM Series Induction Motors

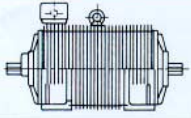
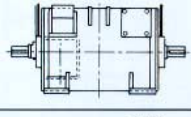
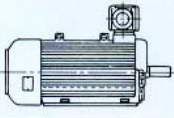
Type	Model	External Appearance
Fully enclosed, frame cooled	TM-E	
Open (or fully enclosed) with duct ventilation	TM-BD (TM-ED)	
Fully enclosed, fan cooled	TM-F	

mine the stress on each motor component. These data were used to raise motor reliability and resistance to shock.

Mitsubishi Electric has developed both AC motors for rolling mills and their inverter drive systems. Recent technologies improve power efficiency, reduce equipment size and lower maintenance requirements. □

SHAFT. Rolling mills must withstand huge shocks and large momentary shaft torques. Mitsubishi Electric has conducted extensive measurements of torque, vibration, control parameters and electrical characteristics in twin-drive reversing AC motor-drive systems in rolling mills under routine working conditions. These data have been used to redesign the shafts of newer motors.

Variable-Speed Induction Motors for Auxiliary-Drive Applications in Rolling Mills

Fully enclosed, frame-cooled motors are attractive to industry because they eliminate the ducting requirements of conventional air-cooled motors. Mitsubishi Electric has developed the TM Series of variable-speed induction motors for rolling line auxiliary-drive applications with a variety of cooling options including frame-cooled, fan-cooled and duct ventilation-cooled models (Table 2).

Compact, fully enclosed, frame-cooled motors have vertical fins that maximize the cooling effects of natural convection. These models are 20% smaller than previous models.

Motors must be able to endure the vibration and shock that arise in many rolling mill applications. In developing the TM Series, we measured the vibration acceleration of motors in many steel plant applications. We learned not only the levels of vibration, but conducted vibration tests and performed analyses to deter-

An Industrial Computer System for Iron and Steel Plants

by Kazuo Sena and Noriyoshi Hiratsuka*

Computer systems for controlling iron and steel plants are shifting towards open-system architectures and right-sizing to support better tailoring of systems to applications. Such systems provide an increasingly diverse range of functions that contribute to optimizing the behavior of the overall system. Concerns about realtime performance, reliability and maintainability that guided the design of previous systems are now being supplemented by an increasing orientation toward the use of hardware and software designs based on industry standards. This report covers industrial computer system configuration concepts and introduces the MR Series of industrial computer systems.

Central Concepts

The 1990s have placed various demands on industrial computer systems, including increased control capabilities, expanded data throughput, integration of electrical, instrumentation and computer functions, and more recently, open-system design and down-sized architecture. Since these systems require a large degree of customization, it is crucial that solutions be designed to accommodate a wide variety of applications. Mitsubishi Electric has chosen to meet this need through offering basic systems with building-block expansibility including down-sized solutions. The company's MR Series computers meet the need for high-throughput systems and ME/R Series computers (EWS) are available for open-system applications. A cost-effective downsizing approach using a bottom-line MR Series computer is also available.

Features

The shift from proprietary solutions toward right-sized, open-system solutions in new plants has spawned the demand for upgrades in existing plants that have been operating with proprietary industrial computer systems. The MR3000 Series of industrial computer systems was developed to meet this demand. It offers the following advantages for process control applications in iron and steel plants. (Specifications are listed in Table 1.)

OPEN-SYSTEM ARCHITECTURE WITH REALTIME PERFORMANCE. The MR Series maintains the realtime operating system concept, realtime response and facile system analysis proven in the corporation's previous process controller, offering a POSIX 1003.1a-c-compliant realtime Unix platform with open-system specifications and an outstanding software development environment. This provides the previously unavailable combination of realtime performance and open-system design. Fig. 1 shows the response of MI-RT, Mitsubishi Electric's rugged realtime Unix operating system for the MR Series computers. The MR3000 has a maximum time lag of 0.1ms between an event and startup of a high-

Table 1 MR Series Specifications

Software			
Operating system	MI-RT		
File system	Distributed realtime file system		
Networking	TCP/IP, NFS, X.25, HDLC, BSC		
GUI	X Windows V11R6		
Library	Process I/O, printer, voice announcement, etc.		
Analysis tools	System information viewer, system load collector, system tracer		
Software development for ME/R Series			
Languages	Extended Fortran 77, C, C++		
Tools	Soft Bench, source debugger, picture data generator (E-Vector)		
Hardware			
Model	MR3100	MR3200	MR3300
CPU	80MHz PA-RISC (100 MIPS)		
Max. internal memory	256MB	256MB	512MB
Option slots	2	6	10
Networking	Ethernet, RS232C		
Storage	Fast SCSI-II HD or DAT		
Options			
External memory	Shared memory, nonvolatile memory		
Networking	10 or 100Mbps realtime network, FDDI, ATM, BSC, HDLC		
Storage	Mirrored and/or dual-port hard drives and DAT drives (Fast SCSI-II)		
Process I/O	AI/AO,DI/DO		

*Kazuo Sena and Noriyoshi Hiratsuka are with the Power & Industrial Systems Center.

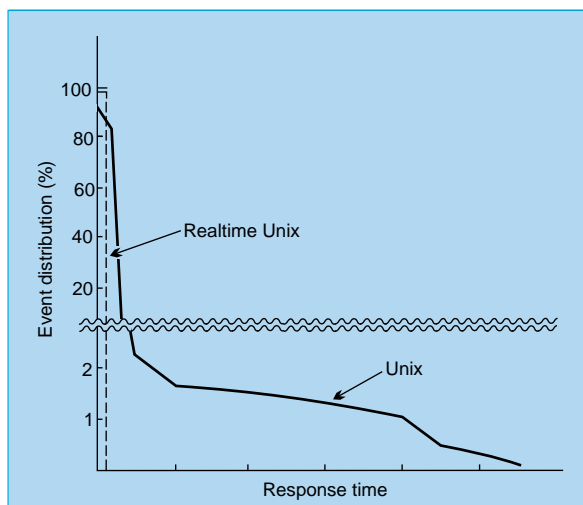

Fig. 1 Response of MI-RT realtime Unix.

priority program triggered by the event when multiple programs are executing simultaneously. The system's response, 100 MIPS performance and communication functions support polling at 20~40ms intervals for hot-strip mill control with regular transmission of system status and fault data. Fig. 2 shows MI-RT's development lineage.

RAPID ARITHMETIC. State-of-the-art high-speed RISC processors provide the top-class arithmetic performance required of industrial process controllers.

RELIABILITY, ACCESSIBILITY AND SERVICEABILITY (RAS). Several functions support continuous operation with high stability, reliability and serviceability. Reliability is obtained through maximum use of LSI devices, disk mirroring and an error retry function for peripheral devices. Continuous operation is supported by the hot plug capability of Model MR3300 and the initialize function. Serviceability is supported by online device diagnostics and error logging.

FLEXIBLE SYSTEM CONFIGURATION. A steel mill control system consists of discrete components connected together including a computer for high-level control, a programmable logic controller for low-level control and an instrumentation system. The networking capabilities of the MR3000 Series allow these various components to be linked flexibly into an integrated system. The MDWS-600S1 integrated control bus provides realtime response where required.

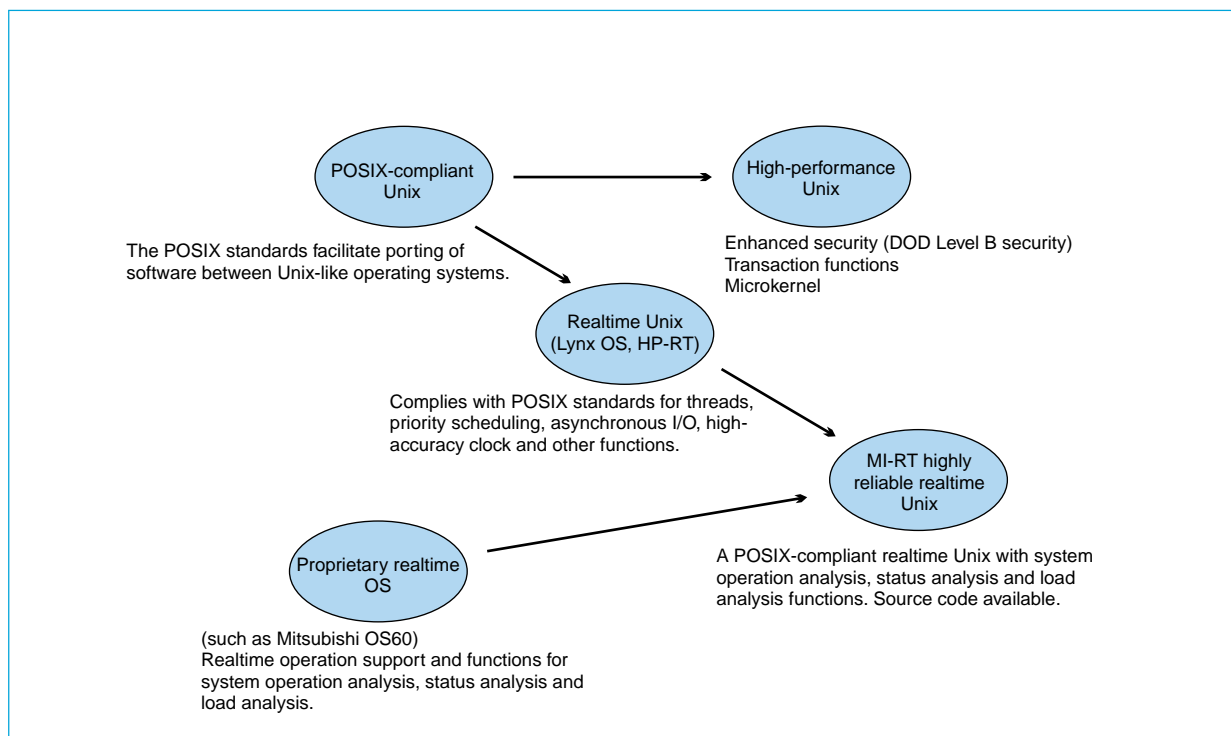

Fig. 2 Development lineage of the MI-RT realtime Unix operating system.

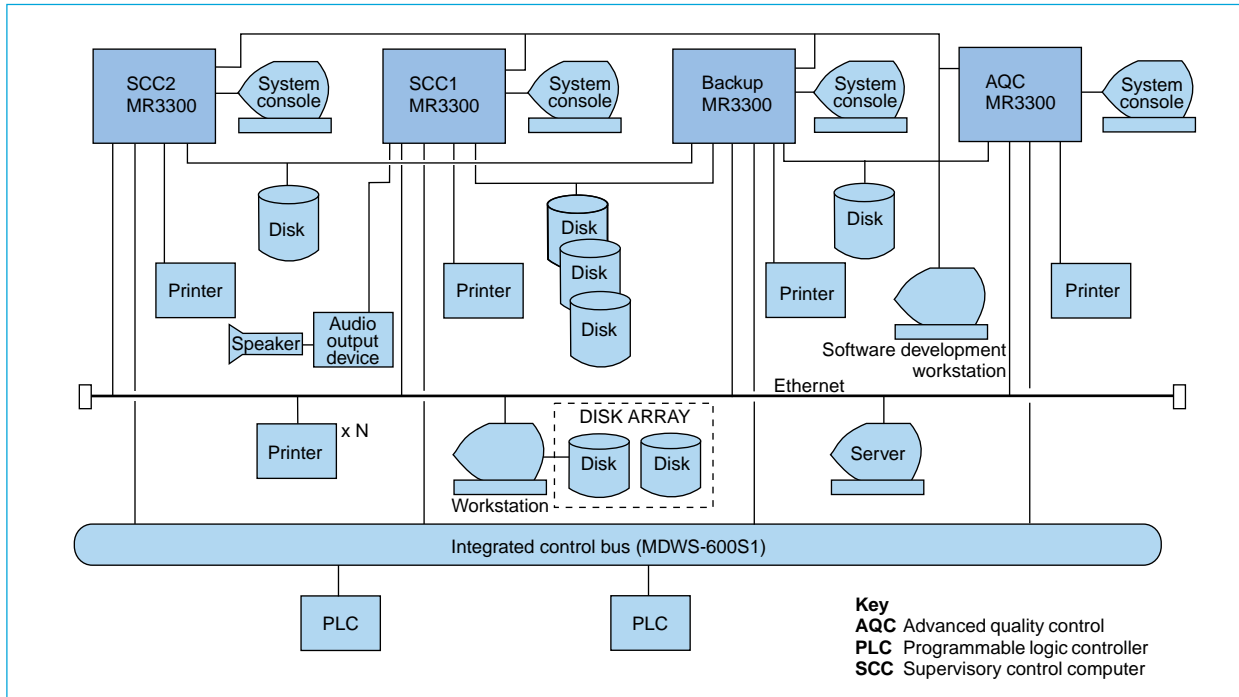

Fig. 3 Configuration of a computer system for a hot-strip mill.

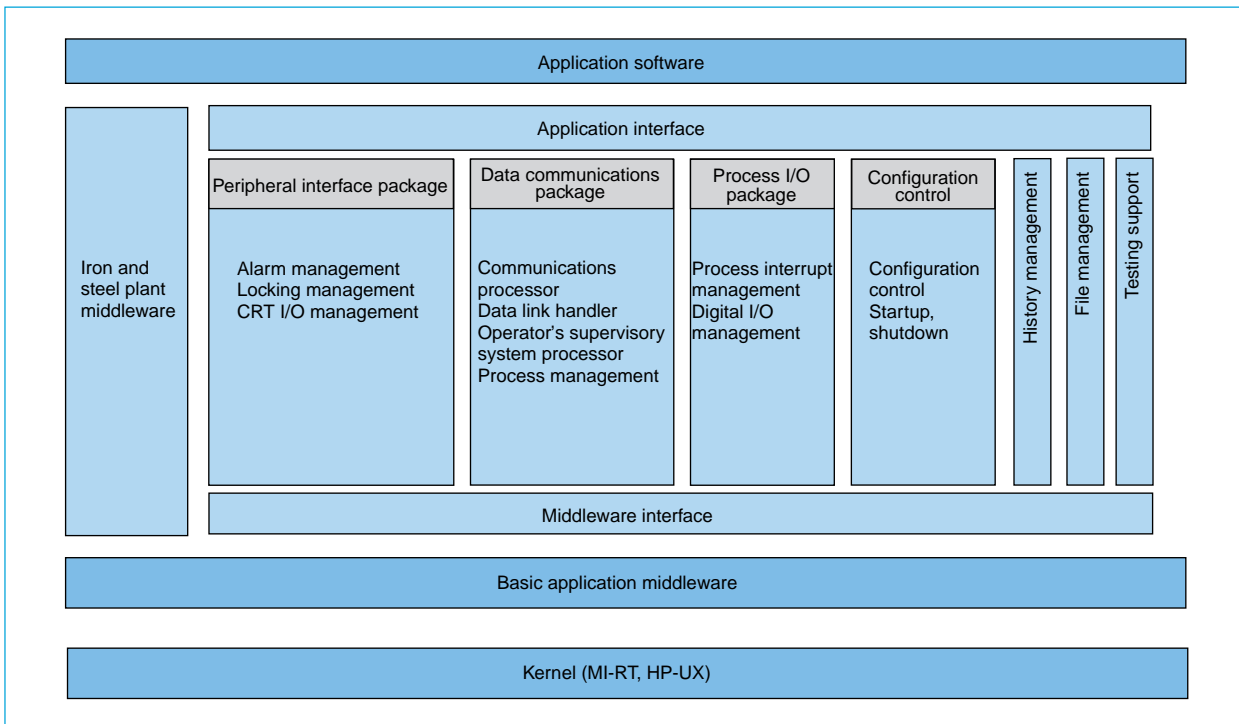

Fig. 4 System software configuration.

Ethernet and ATM networking capabilities meet the need for open systems and multivendor operation. Other communication capabilities include a line server for easy connectivity to general-purpose computing equipment as well as Mitsubishi control equipment. Fig. 3 illustrates the configuration of a control system for hot-strip mills using the MDW-600S1 integrated control bus.

Software Configuration

In modern control systems, portable application programs are preferred to application programs bound to a particular execution platform. Applications for MR Series computers can also be executed on workstations since the MI-RT operating system is Unix based. Middleware for iron and steel plants permits application software to be developed independently of the execution environment. Fig. 4 shows the software configuration. The middleware allows application programs using a common set of functions to be programmed through a simple user interface. The following paragraphs list the features of software design.

An application program interface (API) consistent with the corporation's previous computer systems allows customers to easily migrate existing applications.

The middleware is divided into execution-machine-dependent and execution-machine-independent functions, and a standard interface (called a middleware interface, MWI) has been established between these two domains. By developing a MWI for each function, middleware can be adapted to each execution machine. Higher testing efficiency and reduced programming requirements lower cost and raise quality.

The MI-RT realtime Unix operating system allows functions to be distributed over an Ethernet LAN, allowing the use of personal-computer-based operator terminals, protocol converters and other intelligent devices. Middleware support for these devices is under development.

A trace function that records operating history at the variable call level can be incorporated to facilitate problem analysis.

The MR Series of industrial computer systems maintains support for legacy applications while offering customers the advantages of a realtime Unix-based open system with a wide variety of connectivity options. □

A Control System for Steel Mills

by Mitsunori Hirayama and Nobuchika Furusawa*

This report introduces the MELPLAC-750 integrated control system for state-of-the-art steel mills. The system consists of a process control computer, plant controller and operator consoles built on an integrated control network that supports a shared process I/O database (Fig. 1).

Controller Features

The processing unit, which incorporates a high-speed RISC processor and dedicated processor, performs bit arithmetic operations in 0.2μs. The controller has a 64k-step POL program capacity for controlling electricity. The instrumentation control capabilities extend to 320 loops. A multiprocessor configuration is available to distribute the processing load and improve control performance.

Software encapsulation and modularization support software development in top-down and reusable-component approaches, with improved online maintenance capability. POL language is supported to maintain upward compatibility with applications developed for previous control systems.

Hardware reliability has been improved through the use of custom LSIs, which lower component

count, and by use of highly reliable devices with lower incidence of failure. Parallel power supplies can be installed so that a single power-supply fault will not stop the system. Fault diagnostic functions in each device support a “first fault” function that assists in locating failures. The application program memory has a battery-free backup function.

Network Features

The MDWS600S1 integrated control network (MDWS stands for Mitsubishi dataway system) is an FDDI-compliant high-capacity network with a bandwidth of 100Mbps. Use of a distributed processor management system (DPMS) allows applications using interprocess communication to be insulated from the complexities of the network layer. A cyclic communication function enables common memory to be shared by multiple plant controllers and a common process I/O database to be established when dataway remote I/O (DRIO) is used. This allows applications to be moved, configuration of 1:N backup systems and use of online simulations to shorten program development time.

Ethernet communications are implemented

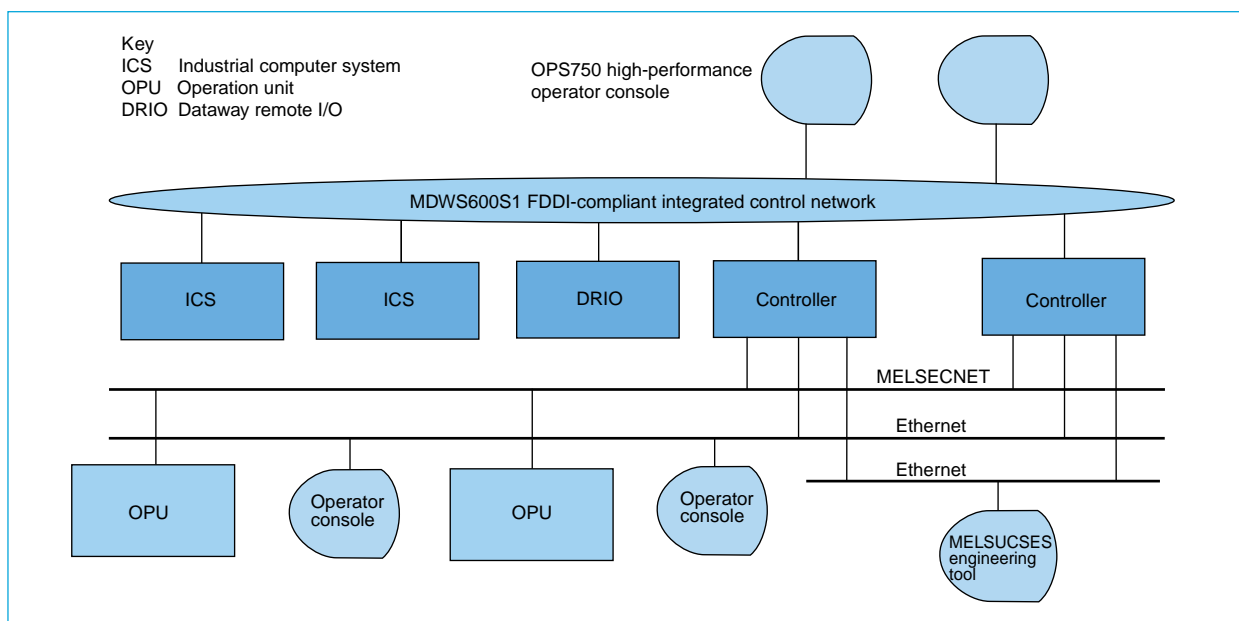

Fig. 1 The control system configuration.

*Mitsunori Hirayama and Nobuchika Furusawa are with the Power & Industrial Systems Center.

Table 1 MELPLAC-750 Network Specifications

	MDWS600S1	Ethernet (TCP/IP, UDP/IP)	MELSEC-NET
Transmission speed	100Mbps	10Mbps	1.25Mbps
Transmission media	Optical fiber cable	10BASE-5/2/T selectable	Optical fiber cable
Topology	Dual loop	Bus/star	Dual loop
Access method	Max. token rotation time control	CSMA/CD	Polling/selecting
N:N communication	50ms/2km/ch (8 channels/station max.)	2kw x 32ch or 4kw x 16ch, active/passive selectable, header and terminator selectable	—
Console interface	—	6 or 14kw buffer read/write by console	—
Cyclic communication	1.7ms/1kw and 30ms/32kw	—	4,096 bits and 4,096 words
Max. stations	126	—	64
Max. station spacing	2km (4km using bypass)	—	1km
Max. overall length	128km	—	10km
Error detection	CRC check	CRC check	CRC check
Error control	Retransmission/cyclic correction	Retransmission	Cyclic correction
Bypass control	Automatic/remote/manual	—	—

using the socket interface of the TCP/IP protocol. Two communication systems are provided: a general-purpose N:N system and a specialized system for the operator console. The protocol processing is performed by a dedicated board that reduces the load on the main processors.

MELSEC-NET supports connection to the operation units (OPU) and general-purpose programmable controllers.

Table 1 lists the MELPLAC-750 network specifications.

Operator Console Features

The OPS750 operator console is a high-performance unit designed specifically to support control of electrical, instrumentation and computer control systems. The console has hierarchical monitoring functions that make it easy to locate irregularities in computers, controllers and other equipment installed on the integrated control network. The console can be operated without programming through the use of standard functions such as alarms, trend graphs and instrument displays, and a graph/table builder.

The operator console consists of an IBM PC AT compatible personal computer fitted with an Ethernet card and running the Windows operating system. Use of *de facto* standards allows the console to utilize the latest advances in hardware and software. A touch-screen is also supported for implementing simplified operating environments.

The operation panel of the OPU has been automated and standardized by combining a sheet keyboard and a programmable controller (Fig. 2). The arrangement of switches and lamps can be easily altered, and name labels changed as necessary to meet individual application re-

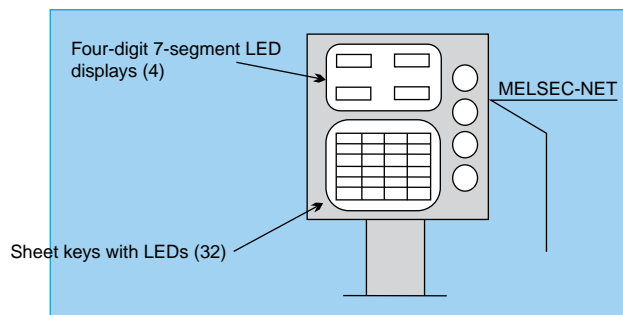

Fig. 2 The operation unit.

quirements. One or more operation units can be connected to the MELSEC-NET network, allowing access to the system from multiple locations and a dramatic reduction in requirements for I/O cards and cabling runs.

Engineering Features

A programming panel designed to be compact and portable supports POL and DDC program development and maintenance. This versatile unit can be used to enter software offline, and to perform a final online setup on the shop floor.

MELSUCSES, the corporation's comprehensive engineering system, provides for unified management of data from many kinds of plants, and supports high-level symbolic description of operation schedules using the Macro Control Diagram (MCD) language. The system supports the entire software life cycle. It conducts syntax checking of operation plans, automatic software generation and transfer, monitoring and hard-copy output of settings data for the integrated control network and software. It also maintains a database of specifications and maintenance data for plant electrical equipment.

Both tools support concurrent engineering architectures in which multiple units are linked to a single controller.

Mitsubishi Electric offers a comprehensive line of hardware and software solutions for the control of steel mills and other manufacturing plants. State-of-the-art networking, database management and concurrent engineering support enable new production facilities to be brought on line with minimum development time. □

A Control Model Analysis Support System for Steel Mills

by Naoki Shimoda and Yoshinori Wakamiya*

Control model analysis support systems for steel mills enable production equipment control algorithms to be fine tuned for better quality in terms of gauge control, width control and shape control. The system analyzes large volumes of process control data to evaluate product quality, control logic efficacy and production equipment status, and provides an efficient method to identify control irregularities and determine their causes.

System Configuration

Fig. 1 shows the system hardware, which includes an online process control computer and an offline data analysis and simulation computer joined by a Ethernet LAN. The process control computer acquires process control data and transfers it periodically to the offline computer, which can analyze the data without affecting the process control computer.

Fig. 2 shows the system software, which consists of a graphic analysis tool and offline simulator functions. The graphic analysis tool extracts data from the process control history database and rapidly converts this data to graphic form for visual inspection. The offline simulator simulates the behavior of the process using two models. The control system simulator simulates the predictive digital feed-forward control and feedback control of the online control system. The physical model simulator uses mathematical models of the controlled objects to simulate their behavior for predictive purposes.

Coiling Temperature Control Analysis Support System

We will now describe the use of the control model analysis support system to analyze coiling temperature control in a hot-rolling mill. Fig. 3 shows the line equipment between the finishing mill and the coiler, and a general diagram of the online process control system. The process control system consists of initial setup prediction control, revised setup prediction control and feedback control. It controls the pouring timing of the laminar bank at the runout table and controls the cooling of the hot strip to provide the specified coiling temperature.

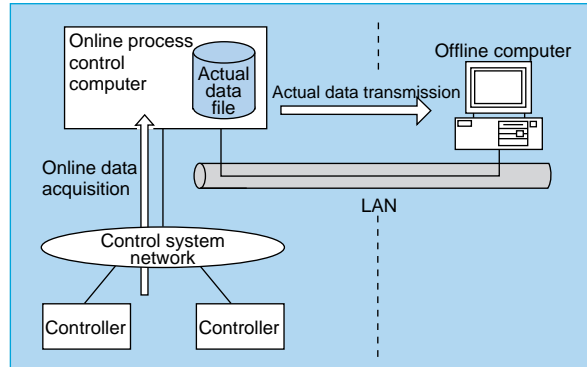

Fig. 1 Hardware configuration.

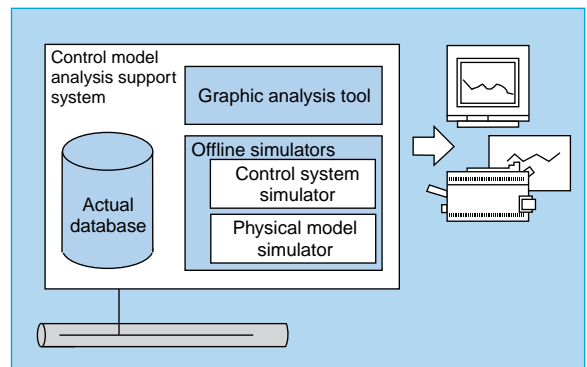

Fig. 2 Software configuration.

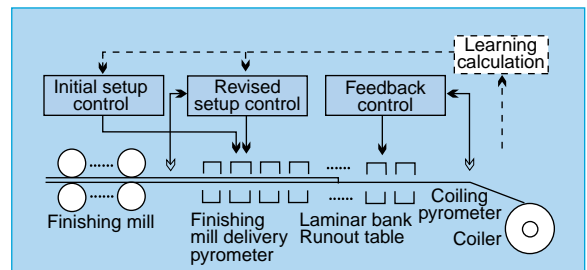

Fig. 3 Coiling temperature control system.

The process control computer for these functions transfers data via a LAN to an offline computer which carries the cooling temperature graphic analysis tool and the coiling temperature control simulation functions.

The cooling temperature graphic analysis tool represents data samples taken over the entire coil length as an analog chart. The user enters date, product number, product size, accuracy and other parameters to define the dataset, and the corresponding data is extracted from the

*Naoki Shimoda and Yoshinori Wakamiya are with the Power & Industrial Systems Center.



Fig. 4 Output of cooling temperature graphic analysis tool.

database and converted to graphic output to identify insufficient cooling and other control inadequacies (Fig. 4).

The coiling temperature control simulator function simulates the control logic of the online control system including both the setup prediction control that determines the switching pattern of laminar pouring control at the runout table and the feedback control activity based on the actual coiling temperature measurement data. The physical model simulator uses mathematical models for the thermal effects of water and air cooling to simulate the cooling behavior of strip on the runout table. The heat flux coefficient for water cooling is adjusted by recursive processing of past process history data, so that the mathematical model faithfully represents the behavior of the actual plant.

The user enters parameters for product num-

ber, product size, target product coiling temperature, etc., causing the system to reference the database for the corresponding dataset, conduct a simulation based on this dataset, and display the actual and simulated data together. The graphs

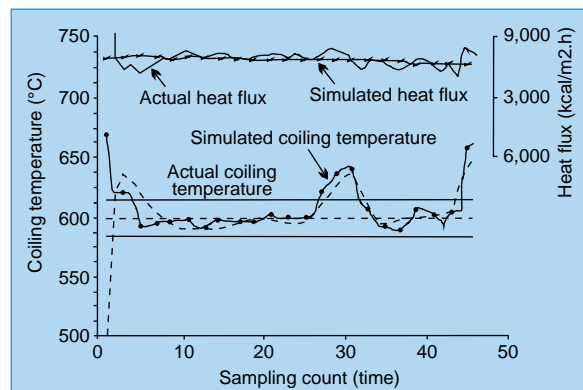

Fig. 5 Output of coiling temperature control simulator.

are compared, and the process control logic and parameters are investigated under those specific conditions where the control performance is inadequate. Fig. 5 shows an example in which both the actual data and simulation show coiling temperature extremes at the coil center well above the target value. The cause is insufficient cooling due to a poor match between the actual transport speed control and the speed control behavior predicted by the initial setup prediction control.

In summary, the use of this system to conduct a detailed analysis of numerous data samples from a single coil makes it possible to attain the precise control required to realize state-of-the-art product quality.

The analytical and simulation capabilities of this sophisticated tool provide a systematic approach to resolving irregularities in steel production processes without disrupting line operation or interfering with operation of the online process control computer. □

Developments in Welders and Induction Heaters for Steel Plants

by Toshinobu Eguchi and Keiji Sodeno*

This article introduces welding equipment for modern steel processing lines: a flash welder with a shear, a mash-seam welder capable of welding seams nearly as thick as the parent material and special-purpose laser-beam welders. The article also describes use of induction heaters to produce high-quality steel pipe and use of computer magnetic-field analysis in induction heater design.

Flash Welders

Recent flash welders often include a shear, unlike previous gauge bars. The corporation's newest flash welder, Model NMW-C, has a rotary shear that can cut strip head and tail simultaneously at the rate of 60m/min, weld at the cut and trim the bead. Strips are butted precisely and automatically in preparation for welding, and handling time is reduced. An original oil-dipped welding technique is available for specialty welding. Oil dipping improves weld quality by excluding oxides from the welding seam when oil combustion consumes oxygen under the cover. Post annealing can be conducted using the flash welder power-supply with the workpiece in position after welding and trimming.

Mash-Seam Welder

A key issue in mash-seam welder design is that the thickness of the weld approach the thick-

ness of the parent material. Fig. 1 compares the ratio of the finished zone to the thickness of the parent material for current and previous welders.

A variety of equipment is available for automated operation. A parallel adjustment unit with a clamp system replaces a conventional side guide for better control of the welding angle. An automatic height adjustment for the lower electrode avoids the possibility for poor seams associated with manual adjustment. An on-line automated electrode-forming unit can be used to prevent quality lapses due to electrode shape irregularities, and an on-line automated weld-quality inspection unit is also available.

Laser-Beam Welders

Laser-beam welders are used for specialty welding applications requiring that the heat-affected zone be as small as possible. As shown in Fig. 2, a laser-beam welder welds faster than a metal-active gas (MAG) welder, which is also a fusion-type welder. The downtime of the input section is reduced because welds almost as thick as the parent material allow a reduction in processing time. Longer welding and handling times compared to flash or mash-seam welders confine applications primarily to specialty welding. Mitsubishi laser-beam welders are supplied as complete solutions, including a mechanism to ensure a precise butt gap and original oscillator technology.

Induction Heater Pipe Welding Applications

We may categorize induction heater equipment

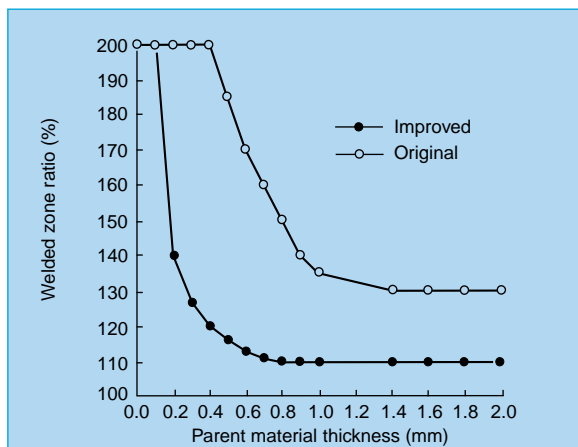

Fig. 1 Ratio of mash-welded zone thickness to parent material thickness.

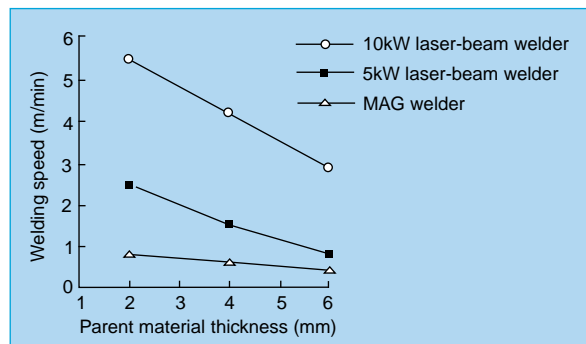

Fig. 2 Welding speeds of laser and MAG welders.

*Toshinobu Eguchi and Keiji Sodeno are with the Itami Works.

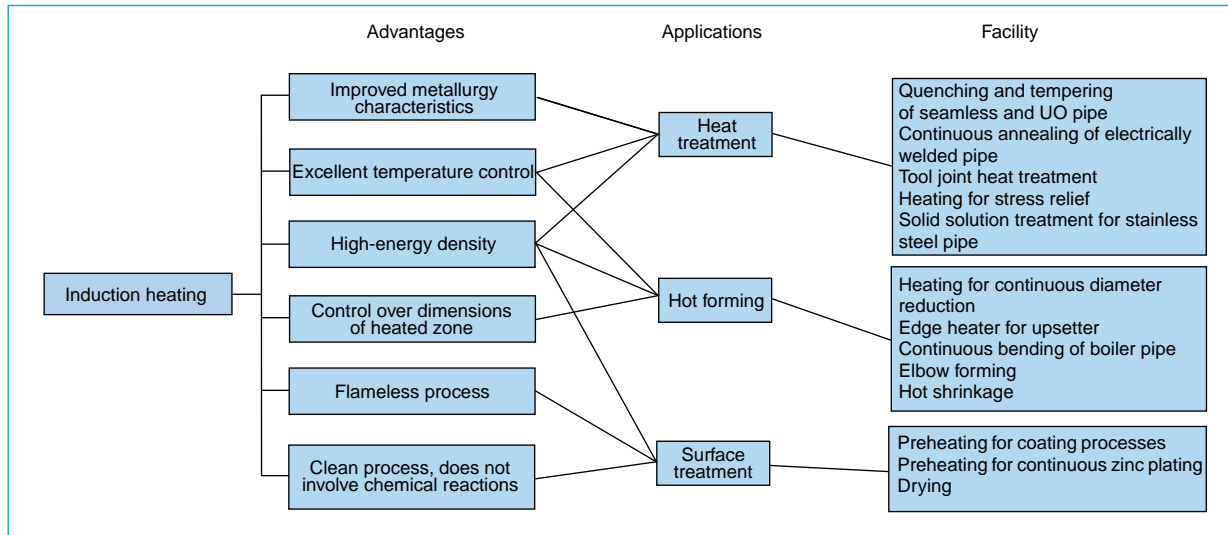

Fig. 3 Advantages and applications of induction heaters for steel pipe processing.

of steel pipe in Japan by application: heat treatment, hot forming and surface treatment (Fig. 3).

SOLID SOLUTION TREATMENT FOR STAINLESS STEEL PIPE. In general, this process is conducted by heating the pipe to the treatment temperature in a furnace and then removing the pipe and rapidly cooling it by water quenching, as specified in the JIS standards. Mitsubishi Electric has delivered lines that take the stainless skelp formed into pipe and perform welding, forming, induction heating, temperature-keeping, quenching, lengthwise forming and cutting in a continuous process with online control. The temperature-keeping step, which provides time for crystal grain diffusion, can be shortened by raising the temperature by 50°C over the conventional treatment temperature.

HEATING FOR CONTINUOUS REDUCTION. The line changes required to produce different pipe products generally require time-consuming process adjustments to suit the type of steel and pipe dimensions. A faster, more continuous approach is to start with a limited selection of skelp materials, form these into pipe and shrink the diameter of this parent material to the required dimensions while the pipe is hot. The parent pipe is usually heated by a combustion furnace,

which has the disadvantages of large space requirement, generation of oxide scale during extended heating, poor controllability, and long furnace startup and shutdown times. Induction heating, by contrast, requires lower capital investment, and where energy transmission efficiency is an issue, the induction heater can be placed at the exit of a heating furnace to reduce electricity consumption.

CONTINUOUS PREHEATING FOR ZINC PLATING. Formed pipe intended for molten zinc plating is preheated prior to immersion in the plating tank. The preheat prevents a drop in tank temperature, improves plating adhesion and results in a stronger plated layer. Induction heating allows preheating in a nitrogen atmosphere that prevents surface oxidation. In addition, the rate of heating can be adjusted to match the line speed, ensuring a uniform workpiece temperature for introduction to the plating tank.

New Technologies for Magnetic-Field and Thermal Analysis

Recent advances in computer hardware and software have made it possible to evaluate complicated magnetic-field and thermal models with a high degree of accuracy. This technology has been applied to induction heater design

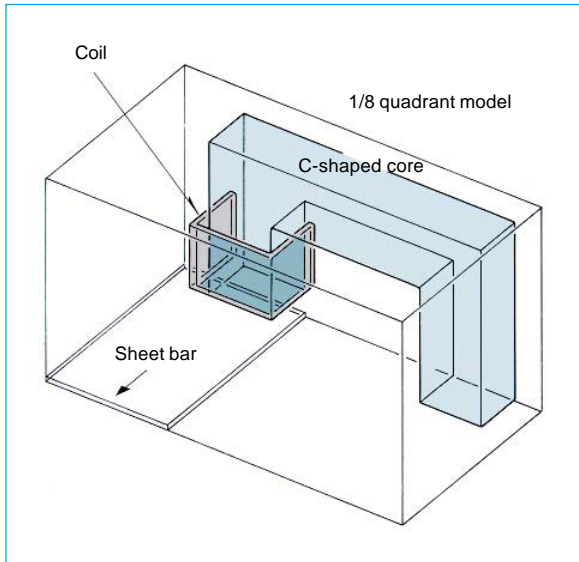

Fig. 4 Analysis model of a C-shaped edge heater.

with excellent results.

Previous two-dimensional analysis is suitable for pipes and billets with radial symmetry, however it cannot indicate more than thermal generation trends for edge heaters and bar heaters and is practically incapable of determining total thermal generation or magnetic flux in sheets or bars. Recent three-dimensional analysis software overcomes these deficiencies and can handle most configurations. This software is extremely useful in developing induction heaters since it allows the determination of optimum heating frequencies, and the thermal generation profile of a design can be tested without fabricating a prototype. Anomalies such as local overheating of nearby metal components can be predicted in advance. Fig. 4 shows modeling of a C-shaped edge heater for a hot-rolling line. Symmetries in the model were exploited to allow modeling of a one-eighth quadrant. Fig. 5 shows a thermal generation density graph for a bar edge heated by this heater.

The improved welders and induction heaters described here are capable of boosting the performance of steel processing lines, and illustrate the continued progress being made in steel processing technologies. □

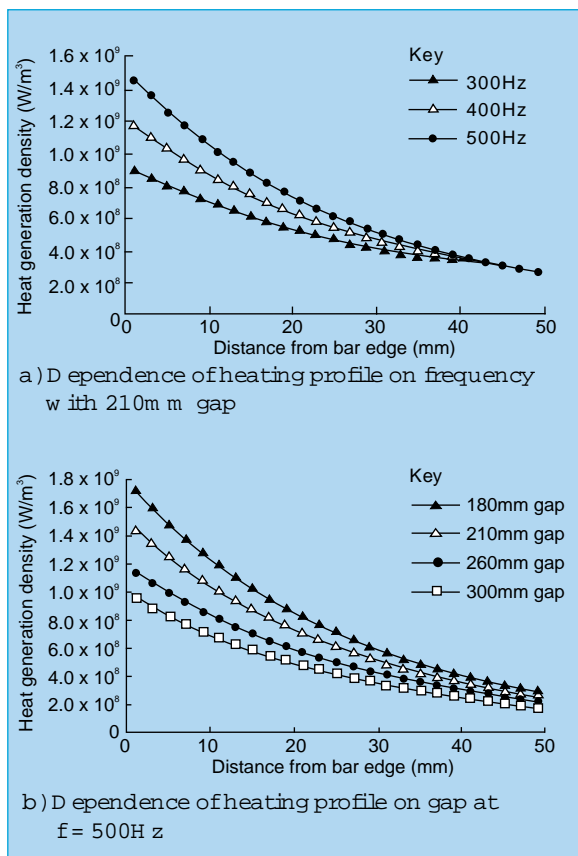

Fig. 5 Heat density pattern at bar edge.

A Novel Regenerative Snubber Circuit for Three-Level GTO Inverters

by Hideo Okayama and Taichiro Tsuchiya*

Three-level inverter circuits use large-capacity gate turn-off (GTO) thyristors to implement drive systems for steel rolling mills. This report describes the circuit operation and characteristics of a novel regenerative snubber circuit that raises the efficiency of three-level GTO inverters.

Circuit Topology

Fig. 1 shows the topology of the new snubber circuit for three-level GTO inverters. The main circuit consists of GTO thyristors, GTO1 - GTO4, freewheeling diodes DF1 - DF4 and clamping diodes DC1 and DC2. The snubber circuit consists of anode reactors LA1 - LA4, snubber capacitors CS1 - CS4 and snubber diodes DS1 - DS4. The snubber circuit lowers switching losses associated with the basic snubber function of limiting the current rate-of-rise during GTO thyristor turn-on and limiting the voltage rate-of-rise and peak off-state voltage during turn-off. The anode reactor stores energy to limit current rate-of-rise while the snubber capacitor stores energy to limit voltage rate-of-rise. All of this stored energy is recovered. It is first transferred to clamping capacitors CO1 - CO4, then passed through DC-to-DC converters DC/DC1 - DC/DC4 for supply to DC link capacitors CF1 and CF2.

Circuit Operation

In this description, we will treat the GTO thyristor as an ideal switch, DC link capacitors CF1 and CF2 as voltage sources of voltage E and the clamping capacitors CO1 - CO4 as sources of voltage e. CS represents the capacitance of CS1 - CS4 (in Farads) and LA the

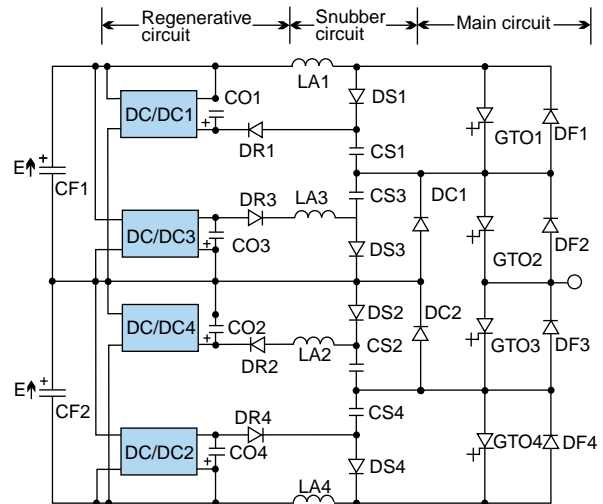

Fig. 1 Regenerative snubber circuit for a three-level GTO inverter.

inductance of anode reactors LA1 - LA4 (in Henrys).

When the outer GTO thyristor (GTO1) turns on, the load current flowing from DC1 to GTO2 is commutated via LA1 to GTO1 and then GTO2. LA1 restricts the current rate-of-rise at GTO1.

$$\left[\frac{di}{dt} \right]_{GTO1} = \frac{E}{LA} \dots\dots\dots (\text{Eq. 1})$$

CS1 discharges and CS3 charges after the load current is commutated.

When GTO1 turns off, the load current that had been flowing bypasses GTO1 via DS1 to CS1. This serves to restrict the voltage rate-of-rise in GTO1.

$$\left[\frac{dv}{dt} \right]_{GTO1} = \frac{E}{LA} \dots\dots\dots (\text{Eq. 2})$$

Then CS3 discharges and the load current is commutated via DC1 to GTO2 as GTO1 completes its turn-off.

When the inner GTO thyristor (GTO2) turns on, the load current, which had been flowing from LA4 to DF4 to DF3 is commutated via DC1 to GTO2 while CS2 discharges. LA2 and LA4 serve to limit the current rate-of-rise at GTO2.

$$\left[\frac{di}{dt} \right]_{GTO2} = \frac{E(1 + \cos \omega t)}{LA} \dots\dots\dots (\text{Eq. 3})$$

$$\omega^2 = (CSLA)^{-1} \dots\dots\dots (\text{Eq. 4})$$

CS4 discharges after the load current is commutated.

When GTO2 turns off, the load current that

*Hideo Okayama and Taichiro Tsuchiya are with the Industrial Electronics & Systems Laboratory.

had been flowing in GTO2 branches, charging CS2 and discharging CS4, which limits the voltage rate-of-rise in GTO2.

$$\left[\frac{dv}{dt} \right]_{GTO2} = \frac{I_o}{2CS} \dots\dots\dots (Eq. 5)$$

The load current is commutated via LA4 to DF4 to DF3, as the GTO2 turn-off is completed. All of the energy stored in the snubber circuits is recovered through the corresponding clamping capacitors.

Switching Duty

We will start by comparing the current rate-of-rise during turn-on of the outer and inner GTO thyristors. Fig. 2 shows the current rate-of-rise vs. time after thyristor turn-on at different inductance values for LA1 and LA2. The DC linlink voltage is 2E = 6,000V and the inductance of anode reactor LA1 is 13μH. The current rate-of-rise for the outer GTO thyristors is constant over the interval that the load current is being commutated. The current rate-of-rise for the inner GTO thyristors is steeper than for the outer GTO thyristors. At n=1, when the inductances of LA2 and LA1 are the same, the current rate-of-rise of the inner GTO thyristors reaches double that of the outer GTO thyristors immediately after turn-on. This steepness is due to the discharge current of the inner snubber capacitors, and declines over time. When n = 2, the ratio of current rate-of-rise for inner to outer GTO thyristors drops to 1.5.

Next, we will compare the voltage rate-of-rise of the outer and inner GTO thyristors during turn-off. Fig. 3 shows voltage rate-of-rise vs. load current characteristics with 6μF snubber capacitors.

Though the voltage rate-of-rise of the outer GTO thyristors is independent of clamping capacitor capacitance, that of the inner GTO

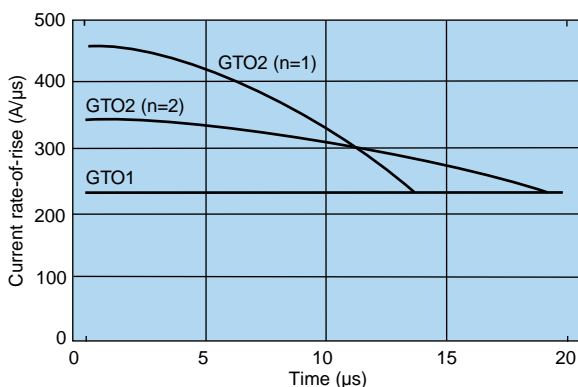

Fig. 2 Current rate-of-rise characteristics of GTO thyristors for LA2 = n LA1.

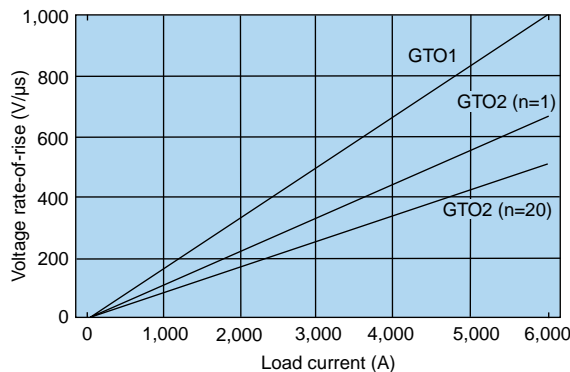

Fig. 3 Voltage rate-of-rise characteristics of GTO thyristors for CO = n CS.

thyristors is dependent on the capacitance.

If the capacitance of the clamping capacitor is an integer multiple (n) of the snubber capacitance, the voltage rate-of-rise of the inner GTO thyristors is given by Eq. 6. From Fig. 3, for n values near 20, the inner GTO thyristor rate-of-rise is about half that of the outer GTO thyristors.

$$\left[\frac{dv}{dt} \right]_{GTO2} = \left(1 + \frac{n}{1+n} \right) \cdot \frac{I_o}{CS} \dots\dots\dots (Eq. 6)$$

Total Commutation Time

We define the total commutation time as the time from the start of switching until all the energy stored in the snubber circuits has been collected by the corresponding clamping capacitors. Figs. 4 and 5 show the total commutation time as a function of the outer GTO thyristor load current and clamping capacitor voltage. The total commutation time characteristics of the inner GTO thyristors (not shown) are similar. The following circuit constants apply:

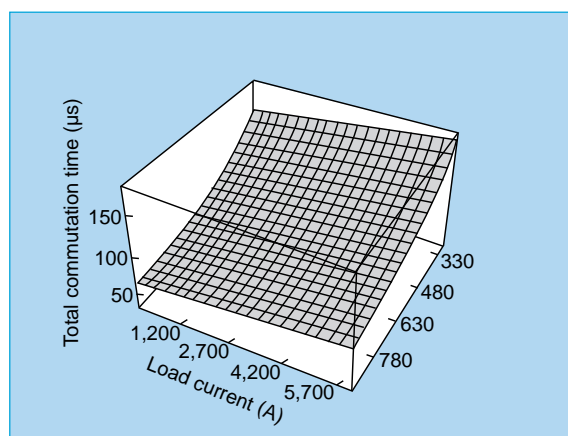

Fig. 4 Total commutation time at turn-on of outer GTO thyristors.

DC ling voltage:	6,000V
Snubber capacitance:	6 μ F
Anode reactor inductance:	13 μ H

Fig. 4 shows that the total turn-on commutation time is proportional to the load current. Two factors are responsible for this relationship. The load current commutation time following turn-on is proportional to the load current, and the load current after commutation is affected only by circuit constants with no dependence on the load current magnitude.

Fig. 5 shows that the total turn-off commutation time for the operation varies strongly with load current and places a limitation on the minimum pulse width available for pulse-width modulation (PWM) applications.

In the snubber circuit we developed, the energy stored is transferred to the clamping capacitor without going through the DC link capacitor. This gives a relatively wide latitude for choosing the clamping voltage. Both of the figures show that higher clamping voltages lower the total commutation time. Note that increasing the clamping voltage is a factor that leads to higher GTO thyristor peak off-state voltage. The clamping voltage should therefore be chosen as the smallest value that satisfies the minimum pulse width requirements.

Snubber Energy Recovery

Fig. 6 shows the relationship between the snubber energy (stored in clamping capacitors CO1 and CO2 by thyristor operation) and the RMS load current. The following parameters supplement the previously listed constants:

Clamping voltage:	600V
No. of inverter phases:	3
Inverter output frequency:	50Hz
Thyristor switching frequency:	500Hz

The snubber energy values in Fig. 6 also express the regenerative power supplied to the DC link capacitor from DC/DC1 and DC/DC2, which share a common connection to the inverter's three phases.

The energy recovered by CO2 does not depend on the load current and is almost constant, while the energy recovered by CO1 varies strongly with the load current. In sum, the energy by CO1 at zero load current is almost identical to the energy with a 2,200A load current. When the inverter is operated at load currents above 2,200A, the DC/DC1 conversion capacity is selected to accommodate the snubber energy at the maximum load current.

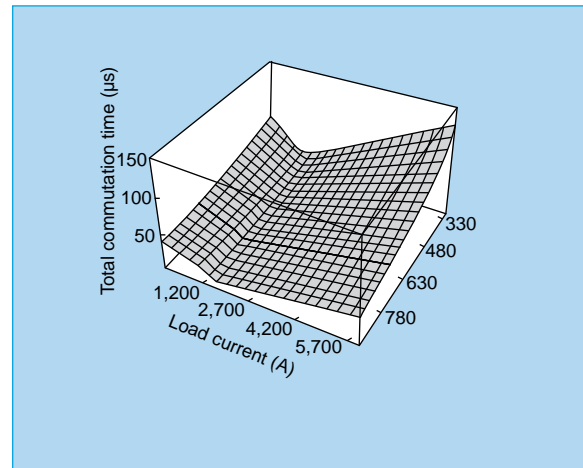

Fig. 5 Total commutation time at turn-off of outer GTO thyristors.

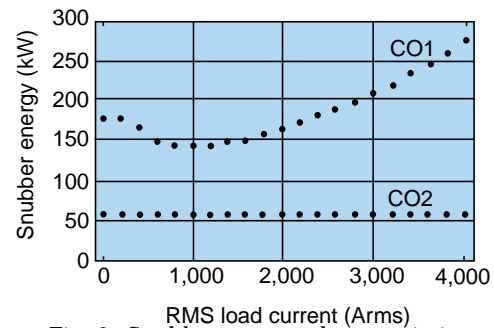

Fig. 6 Snubber energy characteristics.

The high-efficiency three-level GTO thyristor inverter circuit presented here can also be applied to a converter that permits high power-factor operation with low harmonic components and reduced reactive power.

The application of three-level GTO converter-inverters combining these advantages will promote more efficient operation of steel rolling mill drive systems currently using cycloconverters. □

Profile Sensors for Iron and Steel Plants

by Katsuya Ueki and Masayuki Sugiyama*

The authors have developed sensor systems to measure the profiles of steel plate and slab being formed on rolling lines. The differential processing technologies used in the sensor system largely eliminate measurement error due to vibration noise originating in the transport system. These technologies have been used to implement stable measurement for flatness and crop as well as width and length profile in hot-rolling lines for steel plate production. In this article, we will introduce features of profile measurement systems developed for this application.

to accurately measure the profile while the slab is in motion, two cameras scan the line simultaneously at a fixed spacing. The difference in the slab-end positions is used to calculate the slab inclination, which is used to calculate the true length from the measured length. A similar arrangement is used to measure the slab width.

Changes in slab temperature are tracked by an automatic gain control (AGC) function that controls the camera charging time, and by varying the mirror rotation speed. This gives the system a wide dynamic range with respect to tem-

perature.

The vibration noise caused by the moving slab is suppressed and a control function for maintaining the CCD cameras level horizontally allow the measurement to be conducted from a position 23m above the line.

Flatness Meter at the Delivery Side of the Finishing Mill

The slab is thinned in the finishing mill, making it subject to shape distortions such as edge waving and center buckling caused by pressure imbalances across the steel plate width. Noncontact measurements

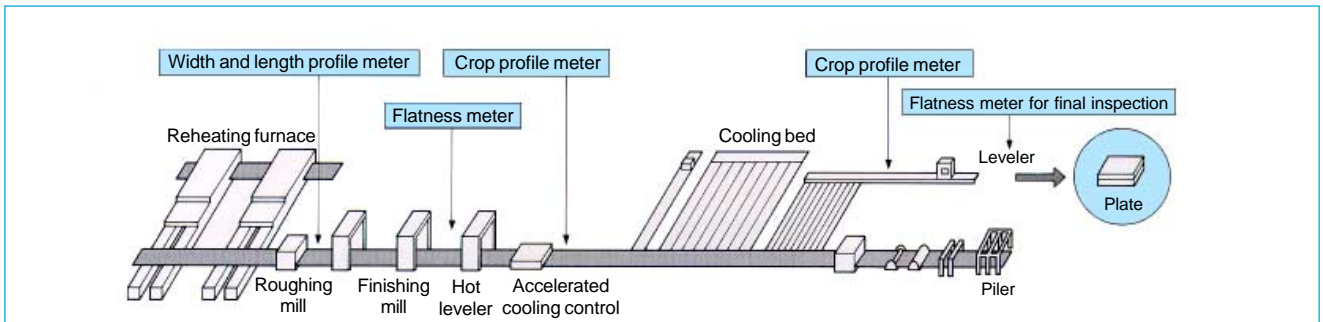

Fig. 1 Illustration of a hot-rolling plate mill line.

Width and Length Profile Meter

Fig. 1 is an illustration of a typical hot-rolling steel plate mill. Non-contact measurements of slab width and length are made on the entry or delivery sides of the roughing mill. The slab temperature is approximately 1,000°C. The thermal energy associated with this temperature is detected by a linear-array CCD camera with a line-shaped field of view and the change in energy is used to determine the position of the slab edge. The field of view is scanned back and forth along the slab width using a mirror driven by a high-speed stepping motor at right angles to the field of view (Fig. 2). In order

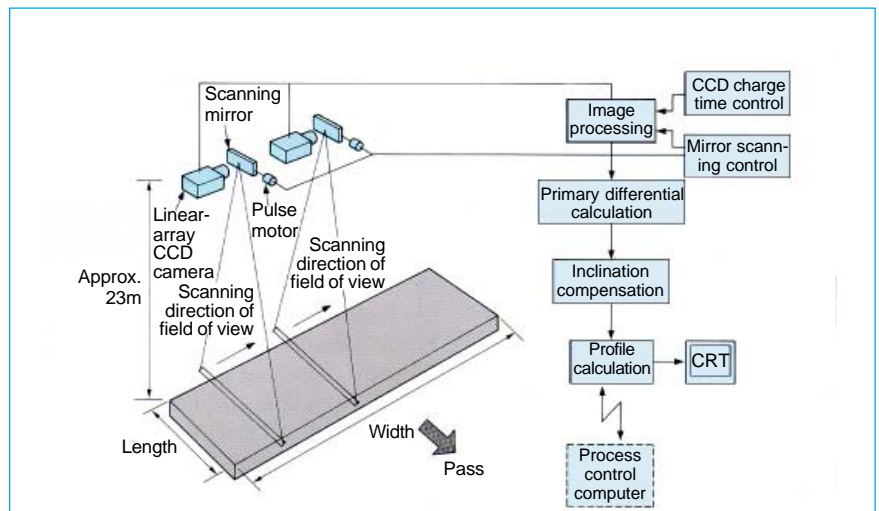

Fig. 2 Block diagram of slab length profile meter.

*Katsuya Ueki and Masayuki Sugiyama are with the Power & Industrial Systems Center.

of these distortions can be made by laser. Linear-array CCD cameras are used to detect laser light reflected off the steel plate. Movements in the position of the laser spot are rapidly converted to measurements of steel plate height displacement. A twin-beam measurement system uses the difference between measurements at two points to eliminate vertical vibration noise, leaving only the steel plate distortion quantities.

If $f(x)$ expresses the wave distortion in the slab and $V(t)$ the vibration component, the displacement of the steel plate ($F(x,t)$) is given by:

$$F(x,t) = f(x) + V(t) \dots\dots\dots (\text{Eq. 1})$$

Differentiating this allows us to eliminate $V(t)$, yielding

$$\frac{dF(x,t)}{dx} = \frac{df(x)}{dx} \dots\dots\dots (\text{Eq. 2})$$

The elongation rate is given by $(S-L)/L$, and the arc length (S) can be determined from the differential vertical displacement (dy) between two points along the length of the steel plate, giving us

$$S = \int_a^b \left[1 + \left(\frac{dy}{dx} \right)^2 \right]^{1/2} dx \dots\dots\dots (\text{Eq. 3})$$

Substituting for the elongation rate yields the following.

$$\beta = \frac{\frac{1}{2} \int_a^b \left(\frac{dy}{dx} \right)^2 dx}{\int_a^b dx} \dots\dots\dots (\text{Eq. 4})$$

By integrating the height difference detected by the twin beams, the vibration components can be eliminated, giving us the elongation rate.

Fig. 3 shows a block diagram of a flatness measurement system using multiple twin-beam laser displacement sensors positioned across the width of the steel plate.

Crop Profile Meter

The head and tail ends of the steel plate exiting the finishing mill have an irregular profile and are unsuit-

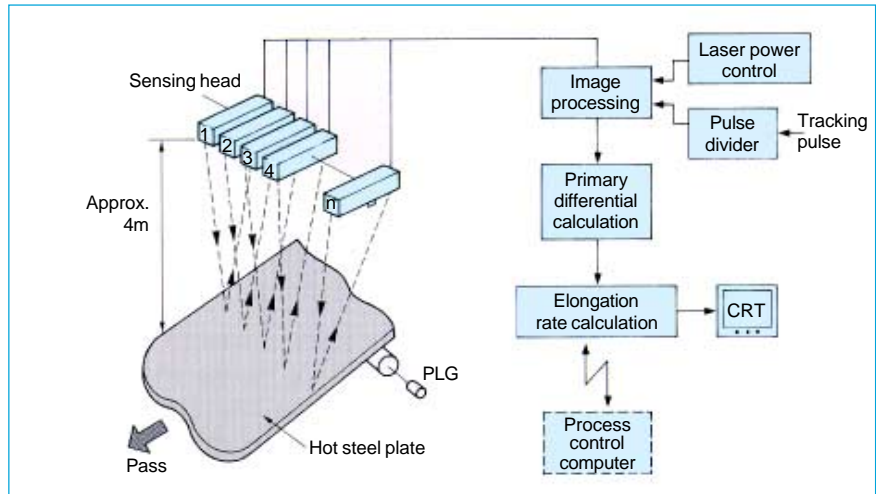

Fig. 3 Block diagram of flatness meter.

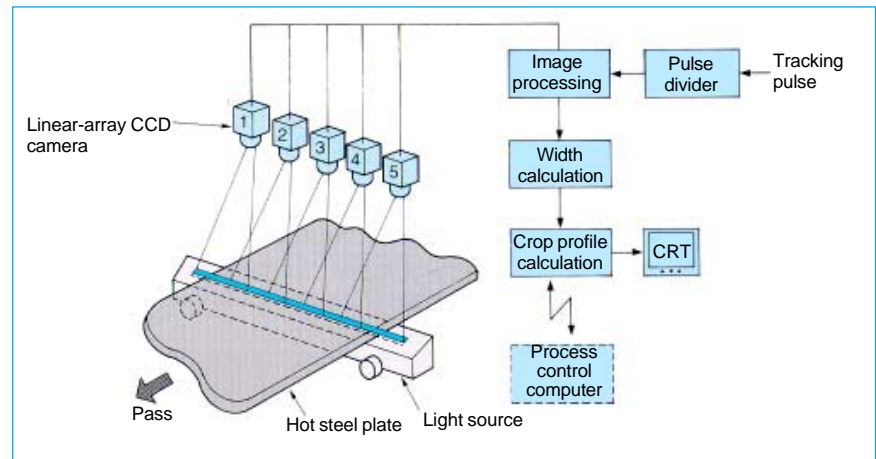

Fig. 4 Block diagram of crop profile meter.

able for use. Two-dimensional profile measurement is needed to determine effective sheet length and the optimum cutting positions. A crop profile meter can be used for two types of measurement methods: an active measurement system using a backlight or a passive measurement system using the steel plate's radiant energy, depending on the steel plate temperature.

Fig. 4 illustrates an active system using a backlight. The field of view of a linear-array CCD camera is oriented across the steel plate width. At fixed increments along the steel plate's length, the camera's video output is passed through an analogue-to-digital converter (ADC) and stored in memory. The light from the backlight is interrupted by the steel plate, creating a silhouette image at each line of measurement. This image information is processed

and noise components are removed, yielding a two-dimensional crop profile.

Use of a high-intensity blue LED allows the backlight system to be used anywhere on the line, regardless of the steel plate temperature. This wavelength is significantly shorter than the central emission wavelength of even hot steel plate, yielding an excellent S/N ratio.

State-of-the-art noncontact measurement systems, such as those described here, can be tied into a mill's control system, making it possible to produce steel plate with greater accuracy and dimensional uniformity. □

A New Database Architecture for Generalized Object Tracking

by Hideyuki Takada and Joji Ido*

This article reports on database middleware products that support tracking in production processes and effective data utilization. Incorporation of this middleware permits the use of common tracking mechanisms for applications and synthesis or the processing of acquired data.

Database Configuration

Fig. 1 shows the overall configuration of the entire database system. The system is configured in two layers: a realtime data server (RTDS) that meets realtime performance requirements of plant processes and a realtime view server (RTVS), a high-performance data supply system that raises application productivity.

The RTDS acquires data from the plant's control network. Data acquisition is conducted by periodic polling or is triggered by specific events. The data is held in a ring buffer. Based on initially defined conditions, workpiece movements in the plant are detected and reported to the RTVS. Time series referencing of data stored in the RTDS is possible.

The RTVS consists of two parts: a tracking manager and a view generator. Based on the workpiece movement reports from the RTDS, the tracking manager can identify the location of each workpiece in the production facility and register this information in the database. The view generator generates multidimensional views of data from either the RTDS or the tracking manager.

Tracking Mechanism

Fig. 2 shows a diagram of the database system's tracking mechanism.

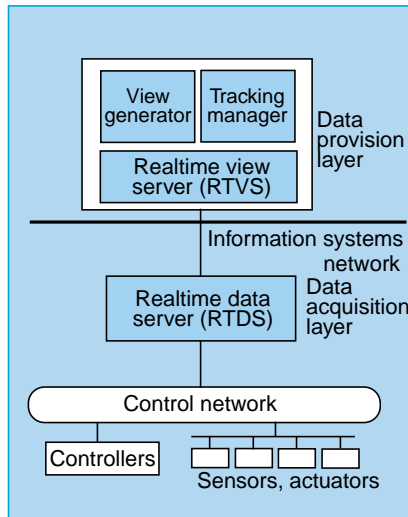

Fig. 1 A diagram of the database system configuration.

The tracking manager performs tracking using unit objects that represent individual processing stations and batch objects that represent

workpieces or sets of workpieces. The "current batch" for the unit object returns the links to those batch objects currently under processing. The "finished batches" for the unit object return the links to batch objects that are waiting to be passed to other processing stations.

Event objects receive reports from the RTDS on workpiece transfers and communicate this information to each affected unit object. When the RTDS reports insertion of a workpiece, the unit object receives the batch object that had been linked to the previous processing station and a link to its own "current batch" is established. When the RTDS reports that processing of a batch unit is completed, the batch unit link to "current batch" is moved to "finished batches."

Links between batch units can

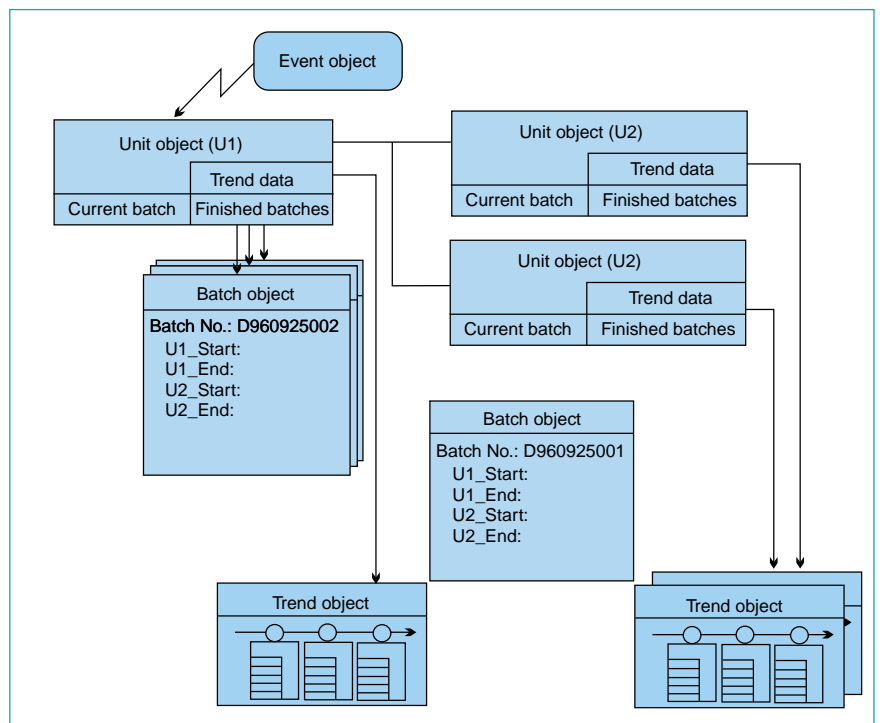

Fig. 2 The tracking mechanism.

*Hideyuki Takada and Joji Ido are with the Industrial Electronics & Systems Laboratory.

also be established to support management of workpieces that separate or join together. To support these links, the tracking manager defines five types of processing stations (Fig. 3). In “processing units,” one input always maps to one output, so that no links between batch units are created. “Mixing units” have a many-to-one mapping with input batch units allowed to differ. “Dividing units” have a one-to-many relationship between inputs and outputs, with outputs that may be identical or differ. “Accumulating units” have a many-to-one relation between inputs and outputs with all inputs identical.

Trend objects, not used for tracking, are time series data sent from the processing station to the RTDS.

Multidimensional View Generation

Tracking data generated as described in the previous section is supplied to the operating staff in the form of multidimensional views that provide a clear picture of production flow.

Fig. 4 illustrates a multidimensional view of the database. Three views are provided of a production process. The top view (plant view) provides an overview of the entire process. The side view (unit view) shows batch units being processed by particular processing units. The front view (batch view) shows how raw materials are transformed into the final product. Each view provides a different interface with specific capabilities.

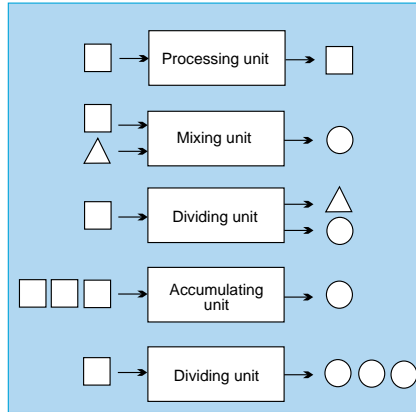

Fig. 3 Types of unit objects.

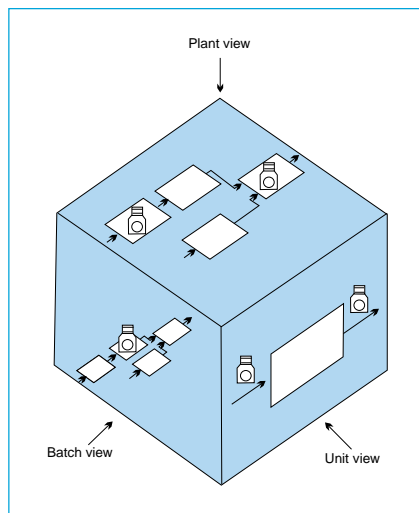

Fig. 4 A multidimensional view.

Computer modeling of a manufacturing plant using the realtime database and object technologies presented here offers plant operators comprehensive supervisory capabilities that promise to improve plant control and raise productivity. □

NEW PRODUCTS

MELCOM 350-MR3000 and M60/3000 Series Industrial Computer Systems

Mitsubishi Electric has developed the MELCOM 350-MR3000 and M60/3000 Series of highly reliable industrial computer systems, designed to serve as the core of information and control systems for industrial plants.

The MR 3000 Series is based on PA-RISC processors and carries the MI-RT operating system, a Posix-compatible Unix-based system with realtime enhancements. The system combines the open systems features of a Unix-like architecture, hardware-based realtime performance and 100MIPS class arithmetic capabilities.

Reliability has been boosted by extensive use of LSIs and a Future-Bus+ system bus. Maintenance is assisted by system status and load monitoring and extensive trace capabilities.

The system software supports high productivity with a full range of middleware and a distributed development environment that allows software development to be conducted on ME/R Series workstations running the HP-UX operating system. The MI-RT operating system supports software development in C and Fortran

while retaining excellent backward compatibility with software developed for previous MELCOM350 Series computers.

Networking capabilities include support for both a general-purpose Ethernet LAN and a realtime ATM-based LAN with priority control and cyclic transmission functions for highly reliable realtime communications. These capabilities support the configuration of sophisticated distributed systems.



A MELCOM 350 Series industrial computer.

The MELVEC-3000 Series Large-Capacity Steel Mill Drive System

Cycloconverters used to implement AC motor drive systems for steel mill rolling lines require a power compensator to protect the power supply from the harmonics and reactive power that a cycloconverter generates. Another drawback is the maximum frequency limited by the power-supply frequency. Mitsubishi Electric has introduced MELVEC-3000 Series three-level PWM GTO converter-inverters as a high-power-factor alternative to cycloconverters.

Several features make GTO inverters ideal for steel mill motor-drive systems.

(1) A high-power-factor converter yields a power factor of 1.0 with harmonics of less than 5%, so that a power compensator is unnecessary.
 (2) The power-supply capacity can be reduced, allowing use of a smaller power transformer with less cabling.
 (3) The switching frequency is independent of the power-supply frequency and can therefore be higher than the power-supply frequency. As a result, the output frequency can be as high as 60Hz, providing a motor speed response of 60 radians/s for a single motor and a current response of 600 radians/s.

The first MELVEC product was

based on a 4" GTO thyristor rated at 4.5kV and 4kA with a 4MVA capacity for a single-unit inverter and an 8MVA capacity for a parallel inverter configuration. In 1993, Mitsubishi Electric was the first company to develop 6" GTO thyristors. The next year, the corporation used these 6kV,

6kA devices to achieve inverter capacities of 10 and 20MVA, allowing a single unit to drive 6~7.5MW steel mill motors, and parallel units to drive loads of up to 15MW. A total of 57 6" GTO inverters have been delivered or are in production. Rapid growth in this market is expected. □

Standard Specifications of MELVEC-3000 Series Converter-Inverters

Capacity (kVA)	4,000	8,000	7,500	10,000	13,000	15,000
Converter circuit						
GTO thyristor element	4kV, 4kA (4")		6kV, 6kA (6")			
Input capacity (kVA)	4,000	8,000	7,500	10,000	13,000	15,000
AC input voltage	2,100V (3 phase)		3,300V (3 phase)			
Permissible input fluctuation	Voltage: ±5% Frequency: ±5%					
DC output voltage	4,000V		6,000V			
Power factor	Better than 0.98					
Control method	3-level PWM					
Inverter circuit						
Output capacity (kVA)	4,000	8,000	7,500	10,000	13,000	15,000
No. of output phases	3					
Max. AC output voltage	2,400V		3,600V			
Output frequency	60Hz					
Overload capacity	150% of rated output for 1 minute					
Modulation method	3-level PWM					
Control methods	Current control combined with speed control or torque control					

A Mediation Technology for the Integration of Heterogeneous Information Resources

Mitsubishi Electric has developed middleware technology for the integration of heterogeneous information resources. This technology enables the integration of existing information resources distributed over networks, including relational, object-oriented, image, flat file and other types of databases as well as application programs such as simulators and AI systems.

As the illustration shows, a module called a 'wrapper' is established for each information resource. The wrapper translates between the data architecture of the specific information resource and a common system data architecture. Application programs send an information referencing request to a module called a 'mediator'. The mediator refers to a mediator specification and automatically gathers the requested information from the appropriate resources via the wrappers and integrates this information, which it returns to the application that issued the original referencing request.

In steel plants, this technology enables the integration of current stand-

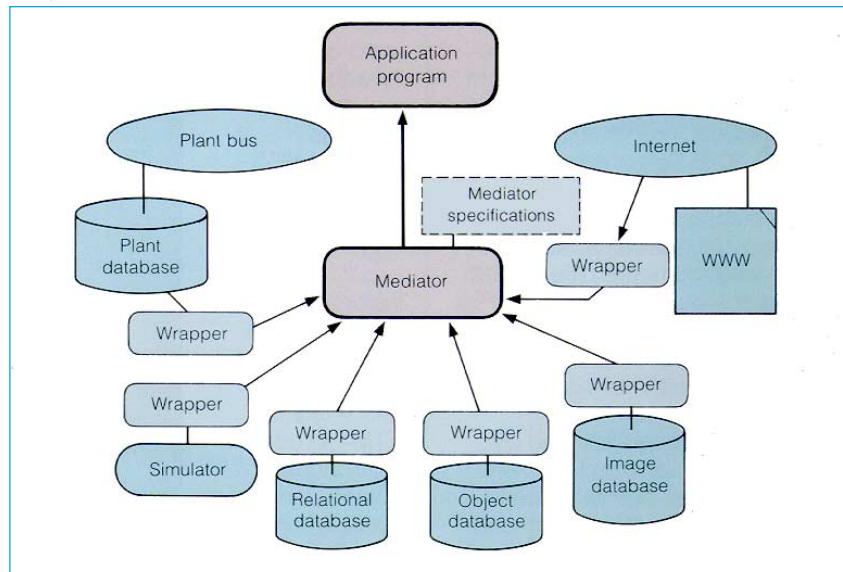

Mediation architecture

alone systems for monitoring, control and production management, allowing easy implementation of distributed information systems. New resources can be easily added by creating a wrapper and updating the mediator specifications, so that the

information system can be readily expanded.

The middleware provides a critical missing function in network programming: the ability to integrate existing databases. Implementation is simple, cost-effective and practical. □

A Media Controller for Industrial Use

Audio and video monitoring can help plant operation staff to run their facility more safely and efficiently. However, the live video signals provided by previous industrial surveillance systems are inappropriate for this application since a single person cannot monitor the signals from numerous cameras. Even when the signals are recorded by VCR, the difficulties of managing and analyzing the video records make applications awkward at best.

Mitsubishi Electric has developed the "Media Controller", an information-processing device that efficiently records and accesses multimedia data for a wide variety of network-based industrial applications. The controller compresses the live video signals it receives from each camera, stores this data temporarily, and makes it available for review. The following capabilities allow a small number of staff to manage the information generated by numerous cameras.

- (1) The video record can be reviewed without disrupting ongoing recording.
- (2) When a plant sensor triggers an alarm signal, the operator can immediately review the video record before and after the event.

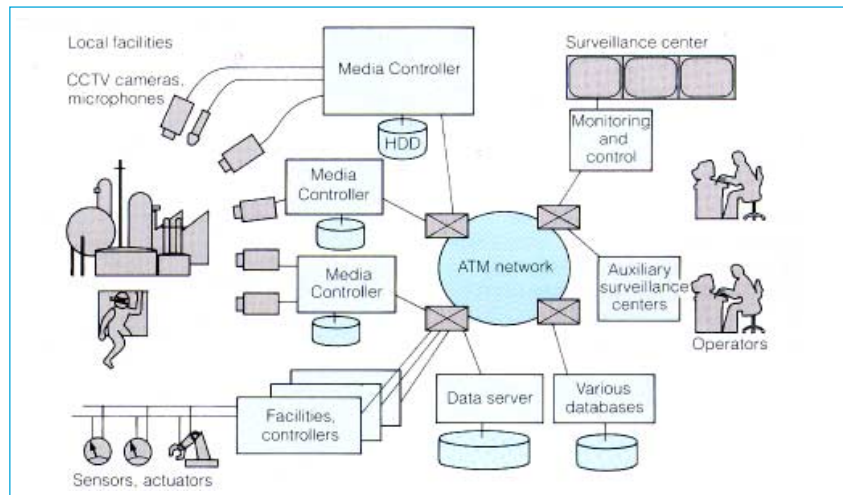

Architecture of multimedia surveillance systems

- (3) Multiple event-triggered video recordings can be made simultaneously.
- (4) Event video data can be stored with links to data in other plants.

Due to the large number of cameras and small number of viewers, the topology of this application differs substantially from video-on-demand systems. Specifically, use of one video storage unit for each installed camera requires an inexpensive digital video storage solution. Mits-

bishi Electric has developed a prototype Media Controller for this purpose using commercially available hard-disk drives.

The controller features a special disk-access algorithm that accesses several video frames at a time to allow recording and multiple playback operations to proceed simultaneously. Use of software pointers allows the inclusion of event records without extra load on the hard-disk drives. □

MITSUBISHI ELECTRIC OVERSEAS NETWORK (Abridged)

Country	Address	Telephone	
U.S.A.	Mitsubishi Electric America, Inc.	5665 Plaza Drive, P.O. Box 6007, Cypress, California 90630-0007	714-220-2500
	Mitsubishi Electronics America, Inc.	5665 Plaza Drive, P.O. Box 6007, Cypress, California 90630-0007	714-220-2500
	Mitsubishi Consumer Electronics America, Inc.	2001 E. Carnegie Avenue, Santa Ana, California 92705	714-261-3200
	Mitsubishi Semiconductor America, Inc.	Three Diamond Lane, Durham, North Carolina 27704	919-479-3333
	Horizon Research, Inc.	1432 Main Street, Waltham, Massachusetts 02154	617-466-8300
	Mitsubishi Electric Power Products Inc.	Thorn Hill Industrial Park, 512 Keystone Drive, Warrendale, Pennsylvania 15086	412-772-2555
	Mitsubishi Electric Manufacturing Cincinnati, Inc.	4773 Bethany Road, Mason, Ohio 45040	513-398-2220
	Astronet Corporation	37 Skyline Drive, Suite 4100, Lake Mary, Florida 32746-6214	407-333-4900
Canada	Powerex, Inc.	Hills Street, Youngwood, Pennsylvania 15697	412-925-7272
	Mitsubishi Electric Research Laboratories, Inc.	201 Broadway, Cambridge, Massachusetts 02139	617-621-7500
Mexico	Mitsubishi Electric Sales Canada Inc.	4299 14th Avenue, Markham, Ontario L3R 0J2	905-475-7728
	Mitsubishi Electronics Industries Canada Inc.	1000 Wye Valley Road, Midland, Ontario L4R 4L8	705-526-7871
Brazil	Melco de Mexico S.A. de C.V.	Mariano Escobedo No. 69, Tlalnepantla, Edo. de Mexico	5-565-6269
	MELCO do Brazil, Com. e Rep. Ltda.	Av. Rio Branco, 123, a 1507, 20040, Rio de Janeiro	21-221-8343
Argentina	MELCO-TEC Rep. Com. e Assessoria Tecnica Ltda.	Av. Rio Branco, 123, a 1507, 20040, Rio de Janeiro	21-221-8343
	MELCO Argentina S.R.L.	Florida 890-20º-Piso, C.P. 1005, Buenos Aires	1-312-6982
Colombia	MELCO de Colombia Ltda.	Calle 35 No. 7-25, Oficinas No. 1201/02, Edificio, Caxdac, Apartado Aereo 29653, Bogotá	1-287-9277
U.K.	Mitsubishi Electric U.K. Ltd.	Travellers Lane, Hatfield, Herts. AL10 8XB, England	1707-276100
	Apricot Computers Ltd.	3500 Parkside, Birmingham Business Park, Birmingham, B37 7YS, England	21-717-7171
	Mitsubishi Electric Europe Coordination Center	Centre Point (18th Floor), 103 New Oxford Street, London, WC1A 1EB	71-379-7160
France	Mitsubishi Electric France S.A.	55, Avenue de Colmar, 92563, Rueil Malmaison Cedex	1-47-08-78-00
Netherlands	Mitsubishi Electric Netherlands B.V.	3rd Floor, Parnassustoren, Locatellikade 1, 1076 AZ, Amsterdam	20-6790094
Germany	Mitsubishi Electric Europe GmbH	Gothaer Strasse 8, 40880 Ratingen	2102-4860
	Mitsubishi Semiconductor Europe GmbH	Konrad Zuse Strasse 1, 52477 Alsdorf	2404-990
Spain	MELCO Iberica S.A. Barcelona Office	Poligono Industrial "Can Magi", Calle Joan Buscallà 2-4, Apartado de Correos 420, 08190 Sant Cugat del Vallés, Barcelona	3-589-3900
Italy	Mitsubishi Electric Europe GmbH, Milano Office	Centro Direzionale Colleoni, Palazzo Perseo-Ingresso 2, Via Paracelso 12, 20041 Agrate Brianza, Milano	39-60531
China	Shanghai Mitsubishi Elevator Co., Ltd.	811 Jiang Chuan Rd., Minhang, Shanghai	21-4303030
Hong Kong	Mitsubishi Electric (H.K.) Ltd.	41st Floor, Manulife Tower, 169 Electric Road, North Point	510-0555
	Ryoden Holdings Ltd.	10th Floor, Manulife Tower, 169 Electric Road, North Point	887-8870
	Ryoden Merchandising Co., Ltd.	32nd Floor, Manulife Tower, 169 Electric Road, North Point	510-0777
Korea	KEFICO Corporation	410, Dangjung-Dong, Kunpo, Kyunggi-Do	343-51-1403
Taiwan	MELCO Taiwan Co., Ltd.	2nd Floor, Chung-Ling Bldg., No. 363, Sec. 2, Fu-Hsing S. Road, Taipei	2-733-2383
	Shihlin Electric & Engineering Corp.	No. 75, Sec. 6, Chung Shan N. Rd., Taipei	2-834-2662
	China Ryoden Co., Ltd.	Chung-Ling Bldg., No. 363, Sec. 2, Fu-Hsing S. Road, Taipei	2-733-3424
Singapore	Mitsubishi Electric Singapore Pte. Ltd.	152 Beach Road #11-06/08, Gateway East, Singapore 189721	295-5055
	Mitsubishi Electric Sales Singapore Pte. Ltd.	307 Alexandra Road #05-01/02, Mitsubishi Electric Building, Singapore 159943	473-2308
	Mitsubishi Electronics Manufacturing Singapore Pte. Ltd.	3000, Marsiling Road, Singapore 739108	269-9711
	Mitsubishi Electric Asia Coordination Center	307 Alexandra Road #02-02, Mitsubishi Electric Building, Singapore 159943	479-9100
Malaysia	Mitsubishi Electric (Malaysia) Sdn. Bhd.	Plo 32, Kawasan Perindustrian Senai, 81400 Senai, Johor	7-5996060
	Antah MELCO Sales & Services Sdn. Bhd.	3 Jalan 13/1, 46860 Petaling Jaya, Selangor, P.O. Box 1036	3-756-8322
	Ryoden (Malaysia) Sdn. Bhd.	2nd Fl., Wisma Yan, Nos. 17 & 19, Jalan Selangor, 46050 Petaling Jaya	3-755-3277
Thailand	Kang Yong Watana Co., Ltd.	15th Floor, Vanit Bldg., 1126/1, New Petchburi Road, Phayathai, Bangkok 10400	2-255-8550
	Kang Yong Electric Co., Ltd.	67 Moo 11, Bangna-Trad Highway, Km. 20 Bang Plee, Samutprakarn 10540	2-312-8151
	MELCO Manufacturing (Thailand) Co., Ltd.	86 Moo 4, Km. 23 Bangna-Trad, Bangplee, Semudparkarn 10540	2-312-8350-3
	Mitsubishi Elevator Asia Co., Ltd.	Bangpakong Industrial Estate, 700/86-92, Moo 6 Tambon Don Hua Roh, Muang District Chonburi 20000	38-213-170
Philippines	Mitsubishi Electric Asia Coordination Center (Thailand)	17th Floor, Bangna Tower, 2/3 Moo 14, Bangna-Trad Highway 6.5 Km, Bangkawe, Bang Plee, Samutprakarn 10540	2-312-0155-7
	International Elevator & Equipment, Inc.	Km. 23 West Service Road, South Superhighway, Cupang, Muntinlupa, Metro Manila	2-842-3161-5
Australia	Mitsubishi Electric Australia Pty. Ltd.	348 Victoria Road, Postal Bag No. 2, Rydalmere, N.S.W. 2116	2-684-7200
New Zealand	MELCO Sales (N.Z.) Ltd.	1 Parliament St., Lower Hutt, P.O. Box 30-772 Wellington	4-569-7350
Representatives			
China	Mitsubishi Electric Corp. Beijing Office	SCITE Tower, Rm. 1609, Jianguo Menwai, Dajie 22, Beijing	1-512-3222
	Mitsubishi Electric Corp. Shanghai Office	Room No. 1506-8, Shanghai Union Building 100, Yanan-East Street, Shanghai	21-320-2010
Korea	Mitsubishi Electric Corp. Seoul Office	Daehan Kyoyuk Insurance Bldg., Room No. 1204 #1, Chongno 1-ka, Chongno-ku, Seoul	2-732-1531-2
Viet Nam	Mitsubishi Electric Corp. Ho Chi Minh City Office	8 B2, Han Nam Officetel 65, Nguyen Du St., 1st District, Ho Chi Minh City	8-243-984

